

User manual

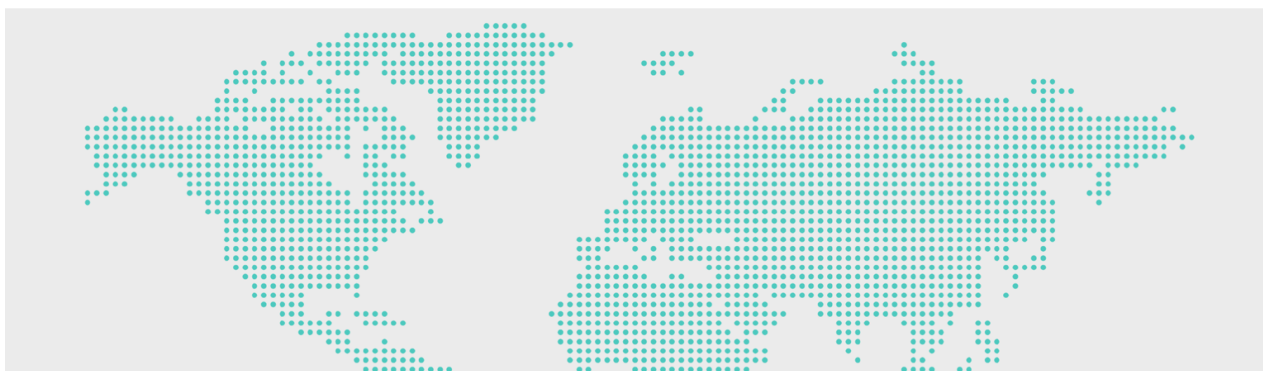

SigenStor-(5S-12S), SigenStor-(5T-30T) Series User Manual

Version: 06
Release date: 2025-12-16



Copyright Notice

Copyright© 2025 Sigenergy Technology Co., Ltd. All Rights Reserved.

Description in this document may contain predictive statements regarding financial and operating results, product portfolio, new technology, configurations and features of product. Several factors could cause difference between actual results and those expressed or implied in the predictive statements. Therefore, description in this document is provided for reference purpose only and constitutes neither an offer nor an acceptance. Sigenergy Technology Co., Ltd. may change the information at any time without notice.

 **SIGENERGY** and other Sigenergy trademarks are owned by Sigenergy Technology Co., Ltd.

All trademarks and registered trademarks in this document belong to their owners.



Website

LinkedIn

YouTube

www.sigenergy.com ↗

Revision History

Version	Date	Description
06	2025.12.16	Updated Product Model Added
05	2025.09.30	Updated Site Selection Requirements
04	2025.08.13	Updated Introduction to energy storage system Upadted Site Selection Requirements
03	2025.02.27	Updated Working Mode Added Backup power setup Added Peak Shaving Control Mode
02	2024.10.17	Updated System Power-on/Power-off
01	2024.08.01	First official release

Overview

Introduction



This document describes product introduction, networking, system operation and maintenance of SigenStor-(5S-12S) and SigenStor-(5T-30T) Series (hereinafter referred to as SigenStor).

Readers

This document is suitable for product users and professionals.

Sign Definition

The following signs may be used in the document to indicate security precautions or key information. Before installation and operation, familiarize yourself with signs and their definitions.

Signs	Definition
 Danger	Danger. Failure to comply will result in death or serious personal injury.
 Warning	Warning. Failure to comply will result in serious personal injury or property damage.
 Caution	Caution. Failure to comply will result in property damage.
Tips	Important or key information, and supplementary operation tips.

Safety Precautions

Basic Information

Before installing, operating, and maintaining the equipment, familiarize yourself with this document.

The "Danger ", "Warning", "Caution" items described in this manual are only supplementary to all precautions.

The Company shall not be liable for equipment damage or property loss caused by the following reasons:

- Failure to obtain approval from the national, regional power authority.
- The installation environment does not meet international, national, or regional standards.
- Failure to observe local laws, regulations and norms when operating and maintaining equipment.
- The installation area does not meet the requirements of the equipment.
- Failure to follow the instructions and precautions in this document.
- Failure to follow the warning labels on equipment or tools.
- Negligent, improper operation or intentional damage.
- Battery capacity loss or irreversible damage caused by your failure to charge the device in time.
- Damage caused by your or a third party's replacement of our equipment (such as mixing our battery pack with other batteries, using our battery pack with other brands of inverters or converters, etc.).
- The equipment is damaged because of your or a third-party company fails to use the accessories supplied with the packing box or purchase and install accessories of the same specification.
- Equipment damage caused by improper operations such as disassembling, replacing, or modifying the software code without authorization.

- Equipment damage caused by force majeure (such as war, earthquake, fire, storm, lightning, flood, debris flow, etc.).
- Damage caused by the failure of the natural environment or external power parameters to meet the standard requirements of the equipment during actual operation (for example, the actual operating temperature of the equipment is too high or too low).
- The equipment was stolen.
- The equipment is damaged after the warranty period.

Safety Requirements

Danger

- The overheated battery pack may cause fire or explosion. Do not expose the device to high temperature or heat sources (such as sunlight, fire, or heaters) around the equipment for a long time.
- Do not clean or soak the equipment with water, alcohol, or oil to avoid power leakage or battery pack leakage.
- Do not knock or impact the equipment. In case of an accident, please stop using the equipment immediately and contact your installer or sales agent. The equipment shall be inspected and evaluated by professional personnel before continuing to use.

Warning

- Do not touch the heat sink when the equipment is running.
- When the equipment is running, do not cover the decorative cover plate and keep the heat dissipation channel of 300–600 mm to avoid fire at high temperature.

Caution

- Do not use the equipment with faults. If the equipment appears abnormal (for example, battery pack leakage or appearance distortion), contact your installer or sales agent. It is prohibited to disassemble the equipment by yourself.

- Carbon dioxide fire extinguishers or ABC dry powder fire extinguishers are recommended at home.
- If the equipment cannot be charged, please contact your installer or sales agent in time.

Do not use the equipment in the following situations:

- When connected to public infrastructure systems.
- When connected to emergency medical equipment.
- When connected to elevators and other control devices.
- Any other critical systems.

Introduction to energy storage system

Product Model

SigenStor contains single-phase inverters and battery packs and can store and release electric energy in response to the management system.

Model	Inverter model	Number of SigenStor BATs 5.0	Number of SigenStor BATs 8.0
SigenStor-5S-5	SigenStor EC 5.0 SP	1	0
SigenStor-5S-8	SigenStor EC 5.0 SP	0	1
SigenStor-5S-10	SigenStor EC 5.0 SP	2	0
SigenStor-5S-13	SigenStor EC 5.0 SP	1	1
SigenStor-5S-16	SigenStor EC 5.0 SP	0	2
SigenStor-6S-8	SigenStor EC 6.0 SP	0	1
SigenStor-6S-10	SigenStor EC 6.0 SP	2	0
SigenStor-6S-13	SigenStor EC 6.0 SP	1	1
SigenStor-6S-16	SigenStor EC 6.0 SP	0	2
SigenStor-6S-24	SigenStor EC 6.0 SP	0	3
SigenStor-8S-8	SigenStor EC 8.0 SP AU	0	1
SigenStor-8S-10	SigenStor EC 8.0 SP AU	2	0
SigenStor-8S-13	SigenStor EC 8.0 SP AU	1	1
SigenStor-8S-16	SigenStor EC 8.0 SP AU	0	2
SigenStor-8S-24	SigenStor EC 8.0 SP AU	0	3
SigenStor-8S-32	SigenStor EC 8.0 SP AU	0	4
SigenStor-8S-40	SigenStor EC 8.0 SP AU	0	5
SigenStor-8S-48	SigenStor EC 8.0 SP AU	0	6

SigenStor-10S-8	SigenStor EC 10.0 SP AU	0	1
SigenStor-10S-10	SigenStor EC 10.0 SP AU	2	0
SigenStor-10S-13	SigenStor EC 10.0 SP AU	1	1
SigenStor-10S-16	SigenStor EC 10.0 SP AU	0	2
SigenStor-10S-24	SigenStor EC 10.0 SP AU	0	3
SigenStor-10S-32	SigenStor EC 10.0 SP AU	0	4
SigenStor-10S-40	SigenStor EC 10.0 SP AU	0	5
SigenStor-10S-48	SigenStor EC 10.0 SP AU	0	6
SigenStor-12S-8	SigenStor EC 12.0 SP AU	0	1
SigenStor-12S-10	SigenStor EC 12.0 SP AU	2	0
SigenStor-12S-13	SigenStor EC 12.0 SP AU	1	1
SigenStor-12S-16	SigenStor EC 12.0 SP AU	0	2
SigenStor-12S-24	SigenStor EC 12.0 SP AU	0	3
SigenStor-12S-32	SigenStor EC 12.0 SP AU	0	4
SigenStor-12S-40	SigenStor EC 12.0 SP AU	0	5
SigenStor-12S-48	SigenStor EC 12.0 SP AU	0	6

SigenStor contains single-phase inverters, SigenStor EVDC and battery packs and can store and release electric energy in response to the management system.

Model	Inverter model	Sigen EV DC Charging Module model	Number of SigenStor BATs 5.0	Number of SigenStor BATs 8.0
SigenStor-8S-EV12-8	SigenStor EC 8.0 SP AU	SigenStor EVDC 12 7.5S2	0	1
SigenStor-8S-EV12-10	SigenStor EC 8.0 SP AU	SigenStor EVDC 12 7.5S2	2	0
SigenStor-8S-EV12-16	SigenStor EC 8.0 SP AU	SigenStor EVDC 12 7.5S2	0	2
SigenStor-8S-EV12-24	SigenStor EC 8.0 SP AU	SigenStor EVDC 12 7.5S2	0	3
SigenStor-8S-EV12-32	SigenStor EC 8.0 SP AU	SigenStor EVDC 12 7.5S2	0	4
SigenStor-8S-EV12-40	SigenStor EC 8.0 SP AU	SigenStor EVDC 12 7.5S2	0	5
SigenStor-8S-EV25-8	SigenStor EC 8.0 SP AU	SigenStor EVDC 25 7.5S2	0	1
SigenStor-8S-EV25-10	SigenStor EC 8.0 SP AU	SigenStor EVDC 25 7.5S2	2	0
SigenStor-8S-EV25-16	SigenStor EC 8.0 SP AU	SigenStor EVDC 25 7.5S2	0	2
SigenStor-8S-EV25-24	SigenStor EC 8.0 SP AU	SigenStor EVDC 25 7.5S2	0	3
SigenStor-8S-EV25-32	SigenStor EC 8.0 SP AU	SigenStor EVDC 25 7.5S2	0	4
SigenStor-8S-EV25-40	SigenStor EC 8.0 SP AU	SigenStor EVDC 25 7.5S2	0	5
SigenStor-10S-EV12-8	SigenStor EC 10.0 SP AU	SigenStor EVDC 12 7.5S2	0	1
SigenStor-10S-EV12-10	SigenStor EC 10.0 SP AU	SigenStor EVDC 12 7.5S2	2	0

SigenStor-10S-EV12-16	SigenStor EC 10.0 SP AU	SigenStor EVDC 12 7.5S2	0	2
SigenStor-10S-EV12-24	SigenStor EC 10.0 SP AU	SigenStor EVDC 12 7.5S2	0	3
SigenStor-10S-EV12-32	SigenStor EC 10.0 SP AU	SigenStor EVDC 12 7.5S2	0	4
SigenStor-10S-EV12-40	SigenStor EC 10.0 SP AU	SigenStor EVDC 12 7.5S2	0	5
SigenStor-10S-EV25-8	SigenStor EC 10.0 SP AU	SigenStor EVDC 25 7.5S2	0	1
SigenStor-10S-EV25-10	SigenStor EC 10.0 SP AU	SigenStor EVDC 25 7.5S2	2	0
SigenStor-10S-EV25-16	SigenStor EC 10.0 SP AU	SigenStor EVDC 25 7.5S2	0	2
SigenStor-10S-EV25-24	SigenStor EC 10.0 SP AU	SigenStor EVDC 25 7.5S2	0	3
SigenStor-10S-EV25-32	SigenStor EC 10.0 SP AU	SigenStor EVDC 25 7.5S2	0	4
SigenStor-10S-EV25-40	SigenStor EC 10.0 SP AU	SigenStor EVDC 25 7.5S2	0	5
SigenStor-12S-EV12-8	SigenStor EC 12.0 SP AU	SigenStor EVDC 12 7.5S2	0	1
SigenStor-12S-EV12-10	SigenStor EC 12.0 SP AU	SigenStor EVDC 12 7.5S2	2	0
SigenStor-12S-EV12-16	SigenStor EC 12.0 SP AU	SigenStor EVDC 12 7.5S2	0	2
SigenStor-12S-EV12-24	SigenStor EC 12.0 SP AU	SigenStor EVDC 12 7.5S2	0	3
SigenStor-12S-EV12-32	SigenStor EC 12.0 SP AU	SigenStor EVDC 12 7.5S2	0	4
SigenStor-12S-EV12-40	SigenStor EC 12.0 SP AU	SigenStor EVDC 12 7.5S2	0	5

SigenStor-12S-EV25-8	SigenStor EC 12.0 SP AU	SigenStor EVDC 25 7.5S2	0	1
SigenStor-12S-EV25-10	SigenStor EC 12.0 SP AU	SigenStor EVDC 25 7.5S2	2	0
SigenStor-12S-EV25-16	SigenStor EC 12.0 SP AU	SigenStor EVDC 25 7.5S2	0	2
SigenStor-12S-EV25-24	SigenStor EC 12.0 SP AU	SigenStor EVDC 25 7.5S2	0	3
SigenStor-12S-EV25-32	SigenStor EC 12.0 SP AU	SigenStor EVDC 25 7.5S2	0	4
SigenStor-12S-EV25-40	SigenStor EC 12.0 SP AU	SigenStor EVDC 25 7.5S2	0	5

SigenStor contains three-phase inverters and battery packs and can store and release electric energy in response to the management system.

Model	Inverter model	Number of SigenStor BATs 5.0	Number of SigenStor BATs 8.0
SigenStor-5T-8	SigenStor EC 5.0 TP AU	0	1
SigenStor-5T-10	SigenStor EC 5.0 TP AU	2	0
SigenStor-5T-13	SigenStor EC 5.0 TP AU	1	1
SigenStor-5T-16	SigenStor EC 5.0 TP AU	0	2
SigenStor-5T-24	SigenStor EC 5.0 TP AU	0	3
SigenStor-10T-8	SigenStor EC 10.0 TP AU	0	1
SigenStor-10T-10	SigenStor EC 10.0 TP AU	2	0
SigenStor-10T-13	SigenStor EC 10.0 TP AU	1	1
SigenStor-10T-16	SigenStor EC 10.0 TP AU	0	2
SigenStor-10T-24	SigenStor EC 10.0 TP AU	0	3
SigenStor-10T-32	SigenStor EC 10.0 TP AU	0	4
SigenStor-10T-40	SigenStor EC 10.0 TP AU	0	5
SigenStor-10T-48	SigenStor EC 10.0 TP AU	0	6
SigenStor-15T-8	SigenStor EC 15.0 TP AU	0	1
SigenStor-15T-10	SigenStor EC 15.0 TP AU	2	0

SigenStor-15T-13	SigenStor EC 15.0 TP AU	1	1
SigenStor-15T-16	SigenStor EC 15.0 TP AU	0	2
SigenStor-15T-24	SigenStor EC 15.0 TP AU	0	3
SigenStor-15T-32	SigenStor EC 15.0 TP AU	0	4
SigenStor-20T-10	SigenStor EC 20.0 TP AU	2	0
SigenStor-20T-13	SigenStor EC 20.0 TP AU	1	1
SigenStor-20T-16	SigenStor EC 20.0 TP AU	0	2
SigenStor-20T-24	SigenStor EC 20.0 TP AU	0	3
SigenStor-20T-32	SigenStor EC 20.0 TP AU	0	4
SigenStor-20T-40	SigenStor EC 20.0 TP AU	0	5
SigenStor-20T-48	SigenStor EC 20.0 TP AU	0	6
SigenStor-25T-10	SigenStor EC 25.0 TP AU	2	0
SigenStor-25T-13	SigenStor EC 25.0 TP AU	1	1
SigenStor-25T-16	SigenStor EC 25.0 TP AU	0	2
SigenStor-25T-24	SigenStor EC 25.0 TP AU	0	3
SigenStor-25T-32	SigenStor EC 25.0 TP AU	0	4

SigenStor-25T-40	SigenStor EC 25.0 TP AU	0	5
SigenStor-25T-48	SigenStor EC 25.0 TP AU	0	6
SigenStor-30T-16	SigenStor EC 30.0 TP AU	0	2
SigenStor-30T-24	SigenStor EC 30.0 TP AU	0	3
SigenStor-30T-32	SigenStor EC 30.0 TP AU	0	4
SigenStor-30T-40	SigenStor EC 30.0 TP AU	0	5
SigenStor-30T-48	SigenStor EC 30.0 TP AU	0	6

Tips

The SigenStor EVDC 12 series supports upgrading the rated output power to 25kW. For specific operations, please refer to the [FAQs](#).

Appearance Introduction

Appearance and Dimensions

Without SigenStor EVDC Series

Tips

The preceding figure takes two SigenStor BATs as an example to show the appearance.

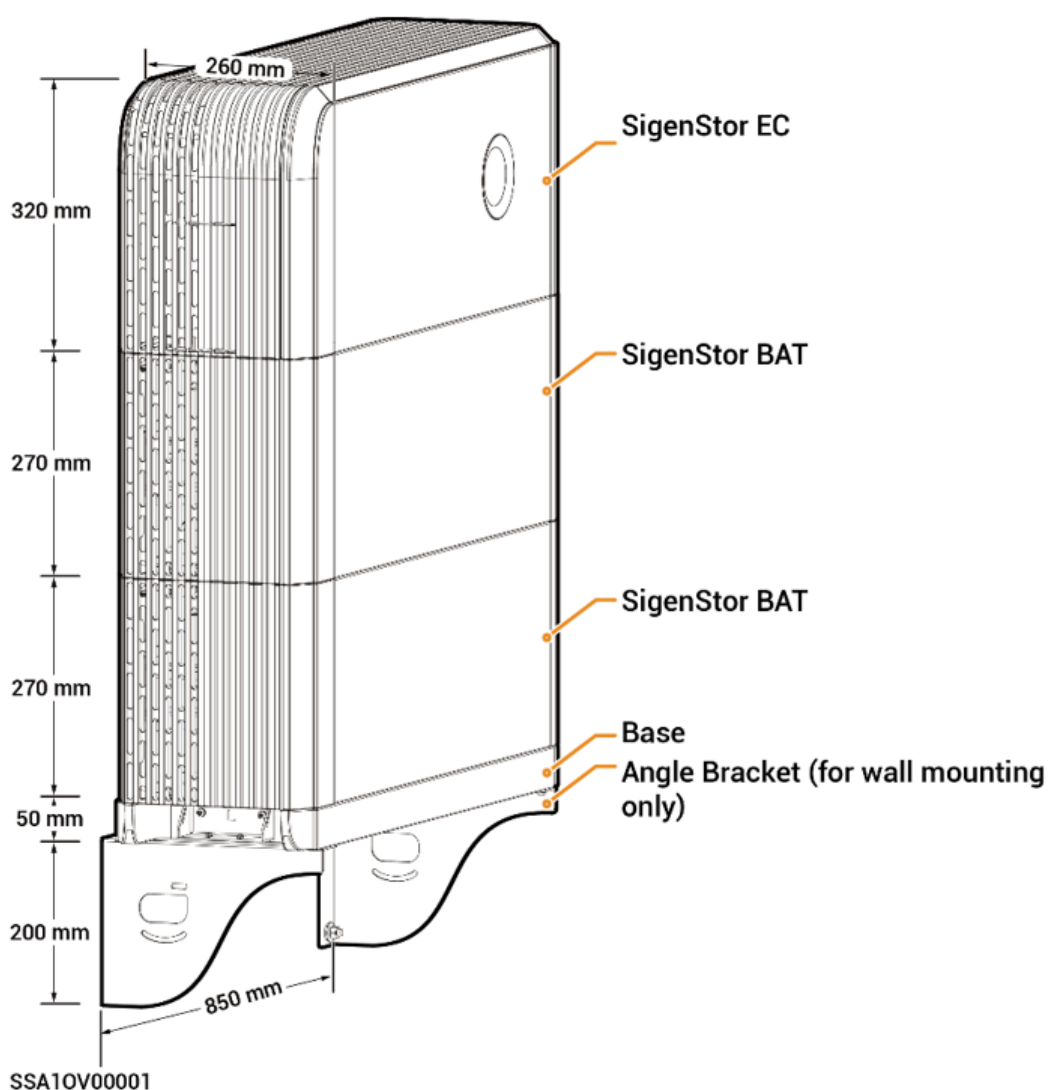

With SigenStor EVDC Series

Tips

The preceding figure takes one SigenStor BAT as an example to show the appearance.

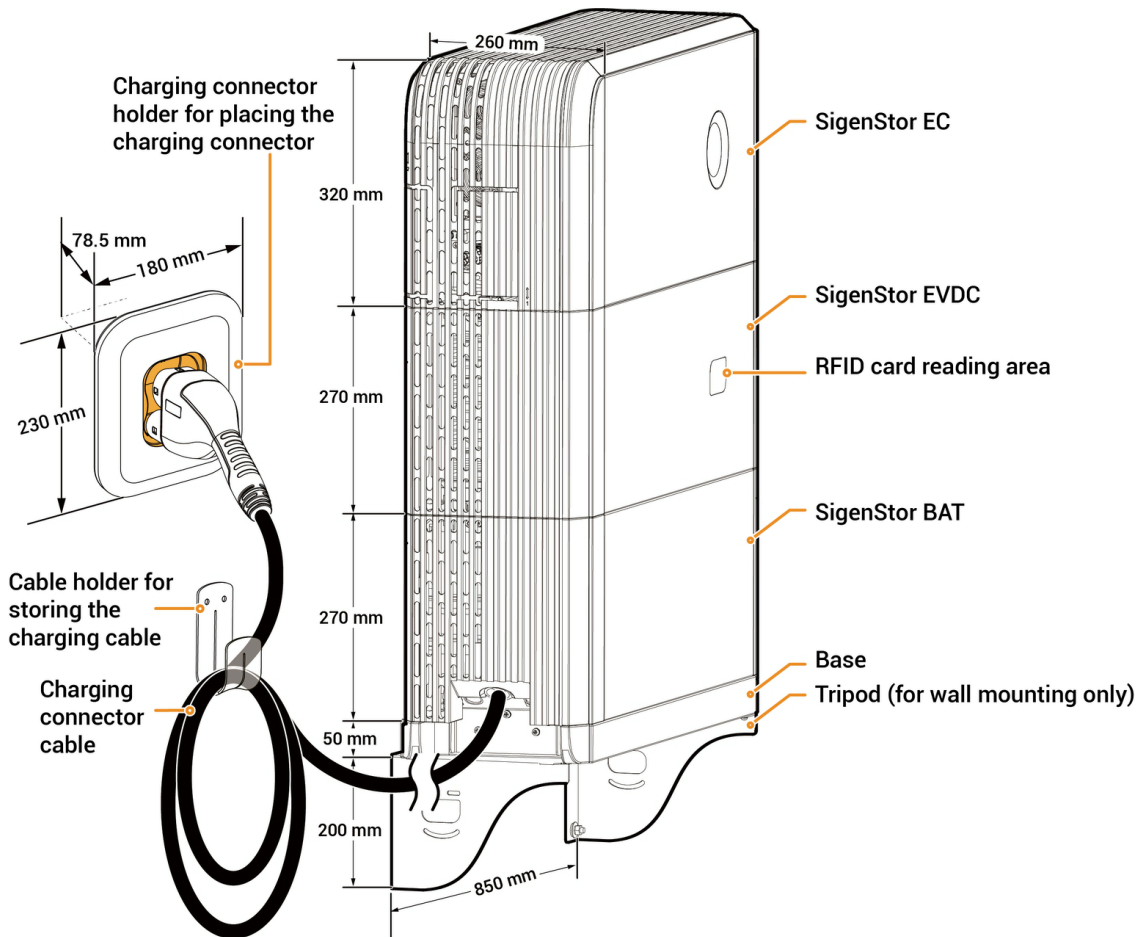

SSA10V00036

Port Introduction

SigenStor EC (5.0, 6.0) SP

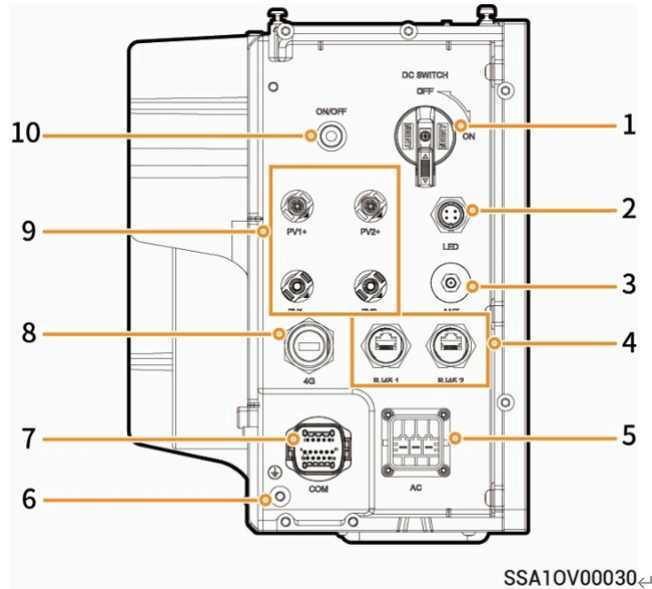

S/N	Name	Marking
1	Dc switch	DC SWITCH
2	Decorative cover light strip connector	LED
3	Antenna interface	ANT
4	Cable interface	RJ45 1/ RJ45 2
5	AC output interface	AC
6	Ground screw	-
7	Communication interface	COM
8	Sigen CommMod interface	4G
9	DC input interface	PV1+/PV2+ / PV1-/PV2-
10	Switch button	ON/OFF

SigenStor EC (5.0–30.0) TP AU

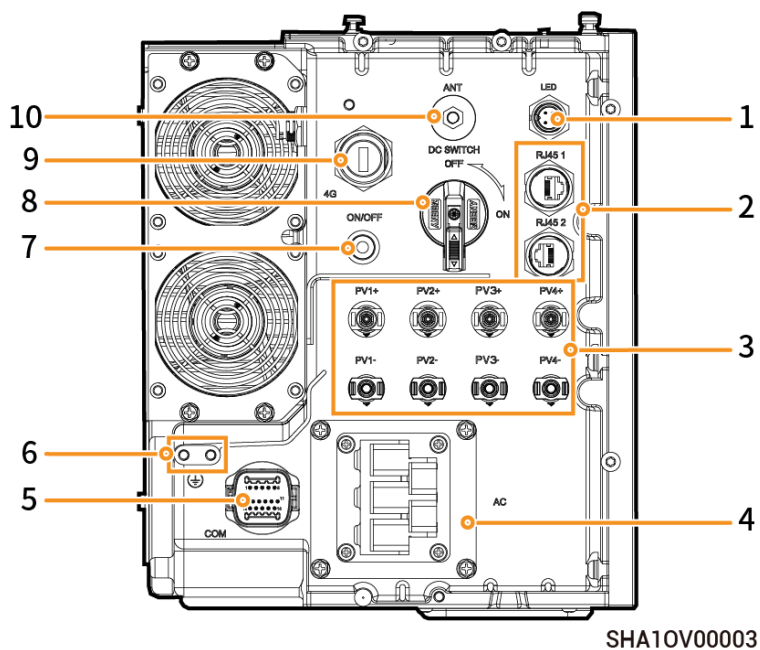

S/N	Name	Marking
1	Decorative cover strip light connector	LED
2	Network interface	RJ45 1/ RJ45 2
3	DC input interface	PV1+/PV2+/ PV3+/PV4+/ PV1-/PV2- /PV3-/PV4-
4	AC output interface	AC
5	Communication interface	COM
6	Ground screw	-
7	Switch button	ON/OFF
8	DC switch	DC SWITCH
9	Sigen CommMod interface	4G
10	Antenna interface	ANT

SigenStor EC-(8.0–12.0) SP AU

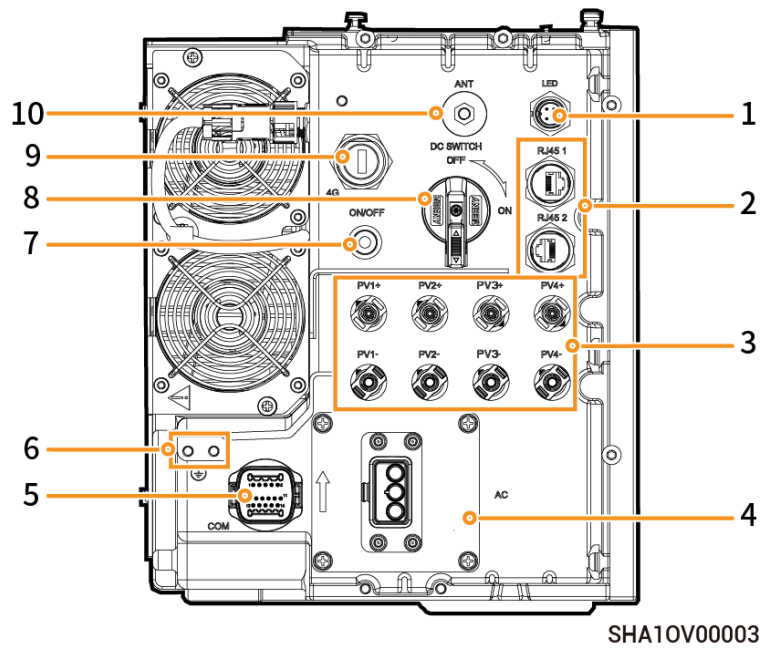

SHA10V00003

S/N	Name	Marking
1	Decorative cover strip light connector	LED
2	Network interface	RJ45 1/ RJ45 2
3	DC input interface	PV1+/PV2+/ PV3+/PV4+/ PV1-/PV2- /PV3-/PV4-
4	AC output interface	AC
5	Communication interface	COM
6	Ground screw	-
7	Switch button	ON/OFF
8	DC switch	DC SWITCH
9	Sigen CommMod interface	4G
10	Antenna interface	ANT

Modular Floating Stacked Connector

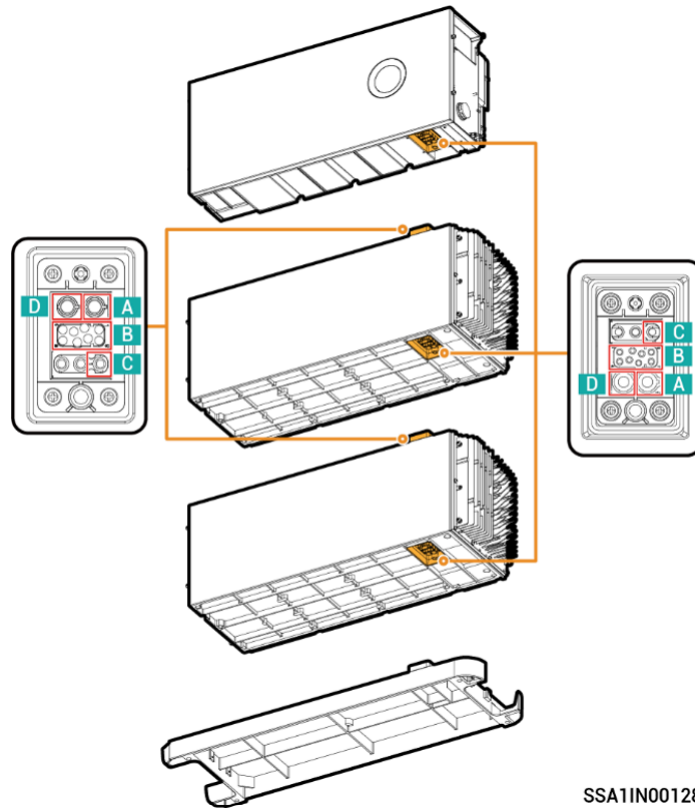

SSA1IN00128

No.	Meaning
A	BAT-
B	Communication interface
C	PE
D	BAT+

Label Description

Symbols	Definition
	<p>Danger! High Voltage</p> <p>High voltage exists inside the equipment when powered on. Do not open the casing when the equipment is running. Any maintenance or servicing operations must be performed by trained and skilled electrical engineers.</p>
	<p>Warning! Life at risk.</p> <p>The equipment has potential hazards after running. Take proper protection when operating the equipment.</p>
	<p>After the equipment is powered off, the discharge of internal components is delayed. Wait 10 minutes until the equipment is fully discharged according to the label time.</p>
	<p>Warning! Risk of burns.</p> <p>The surface of the heat dissipation area is hot when the equipment is running. Do not touch it to avoid burns.</p>
	<p>Please refer to the instructions to operate the equipment.</p>
	<p>Earthing mark</p>

Supported Power Supply Methods for the Power Grid

SigenStor-(5S, 6S) &SigenStor-(8S-12S) Series

- The grid supply methods supported include TN-S, TN-C, TN-C-S, and TT.
- When TT is used as the power supply technique for the power grid, the voltage between N and PE is required to be < 30 V.

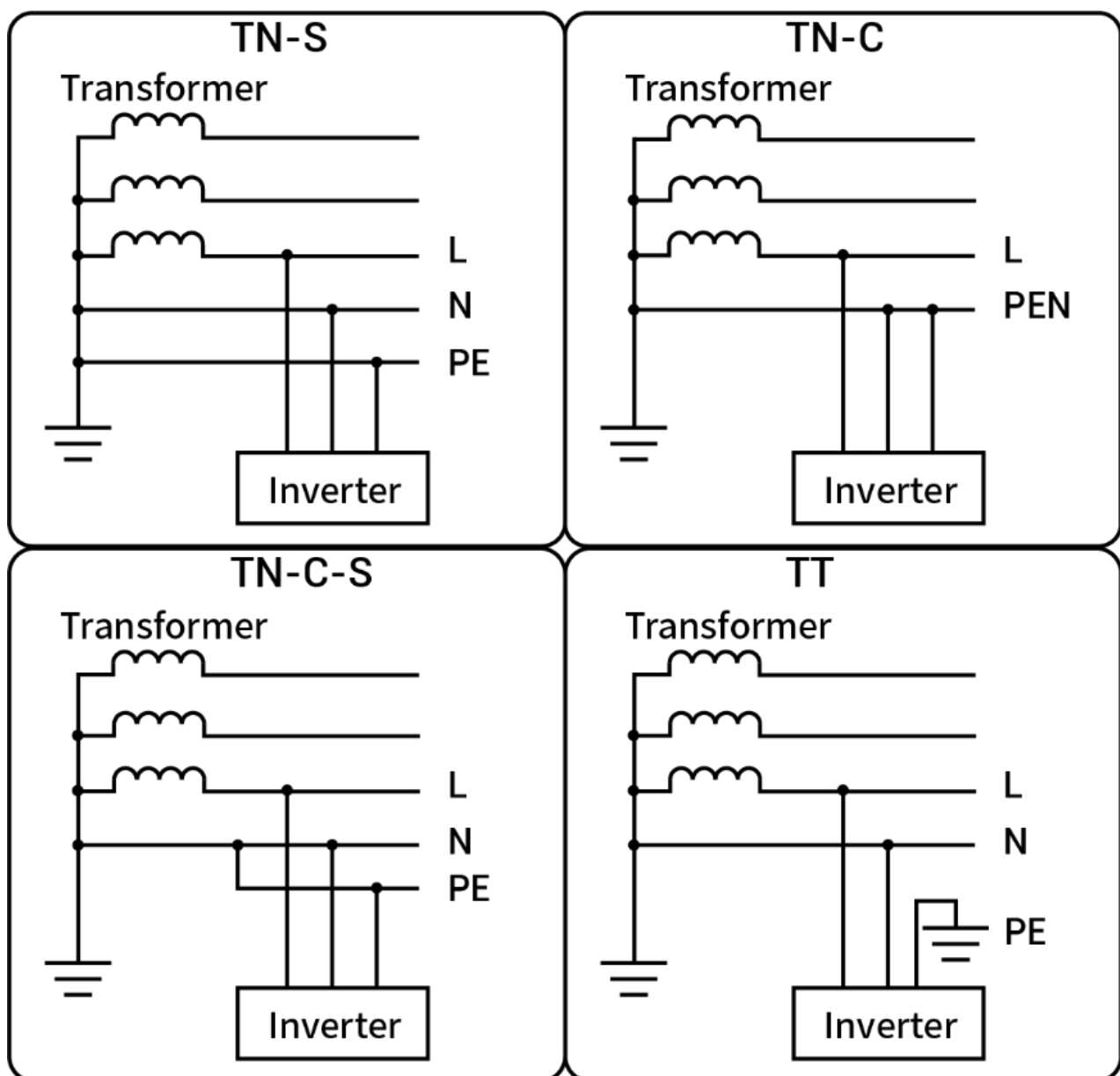

SVA10V00002

SigenStor-(5T-30T) Series

- The grid supply methods supported include TN-S, TN-C, TN-C-S, TT and IT.
- When TT is used as the power supply technique for the power grid, the voltage between N and PE is required to be < 30 V.

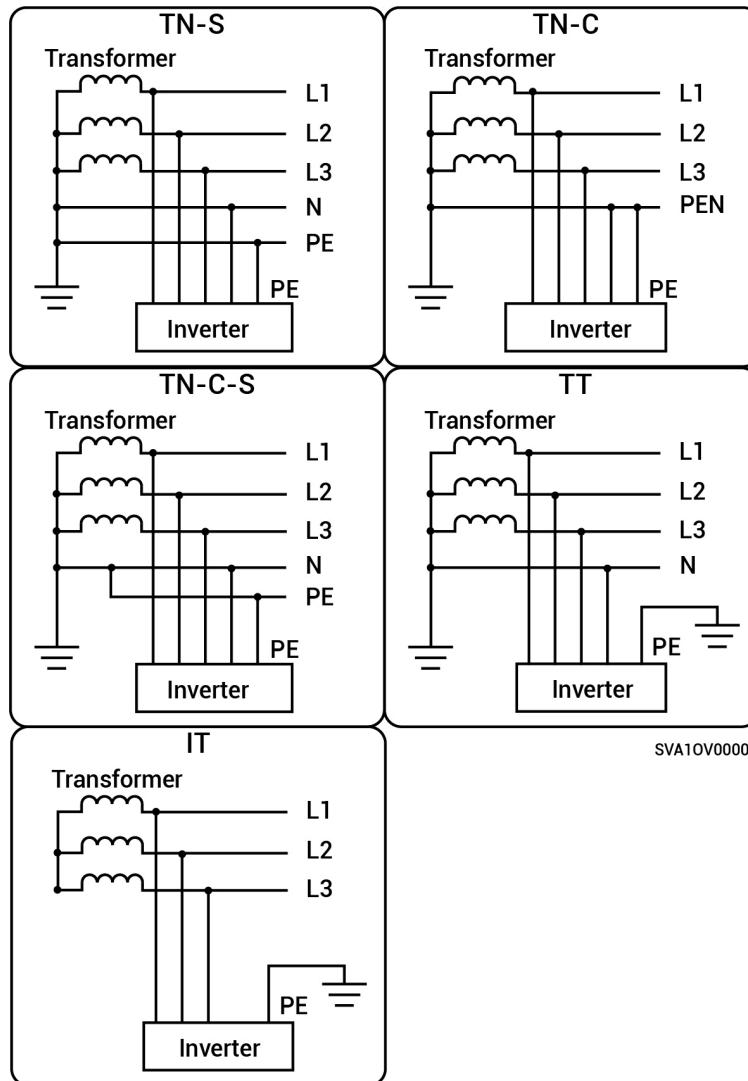

Typical Networking Introduction

- SigenStor can be used for Home energy storage system. The Home energy storage system consists of photovoltaic panels[Note], inverters, battery packs, master control switches, Gateway, loads, power grids, etc.
- The main function of Home energy storage system is to store the direct current generated by photovoltaic panels into battery packs. Or alternatively, the electricity in the photovoltaic system and the battery pack can be converted into alternating current for use by the load or incorporated into the grid.

Note: PV panels with functional grounding cable connected cannot be used.

Tips

Under backup power networking, the duration of off-grid operation of the backup power load is related to the power supply capacity of the PV storage system. If there is an abnormality in the power supply of the PV storage system during off-grid operation (including but not limited to abnormal PV power generation, insufficient battery power, and abnormal power supplies to the diesel generator), the backup power load will still be unable to operate.

Networking Diagram (Whole Home Backup)

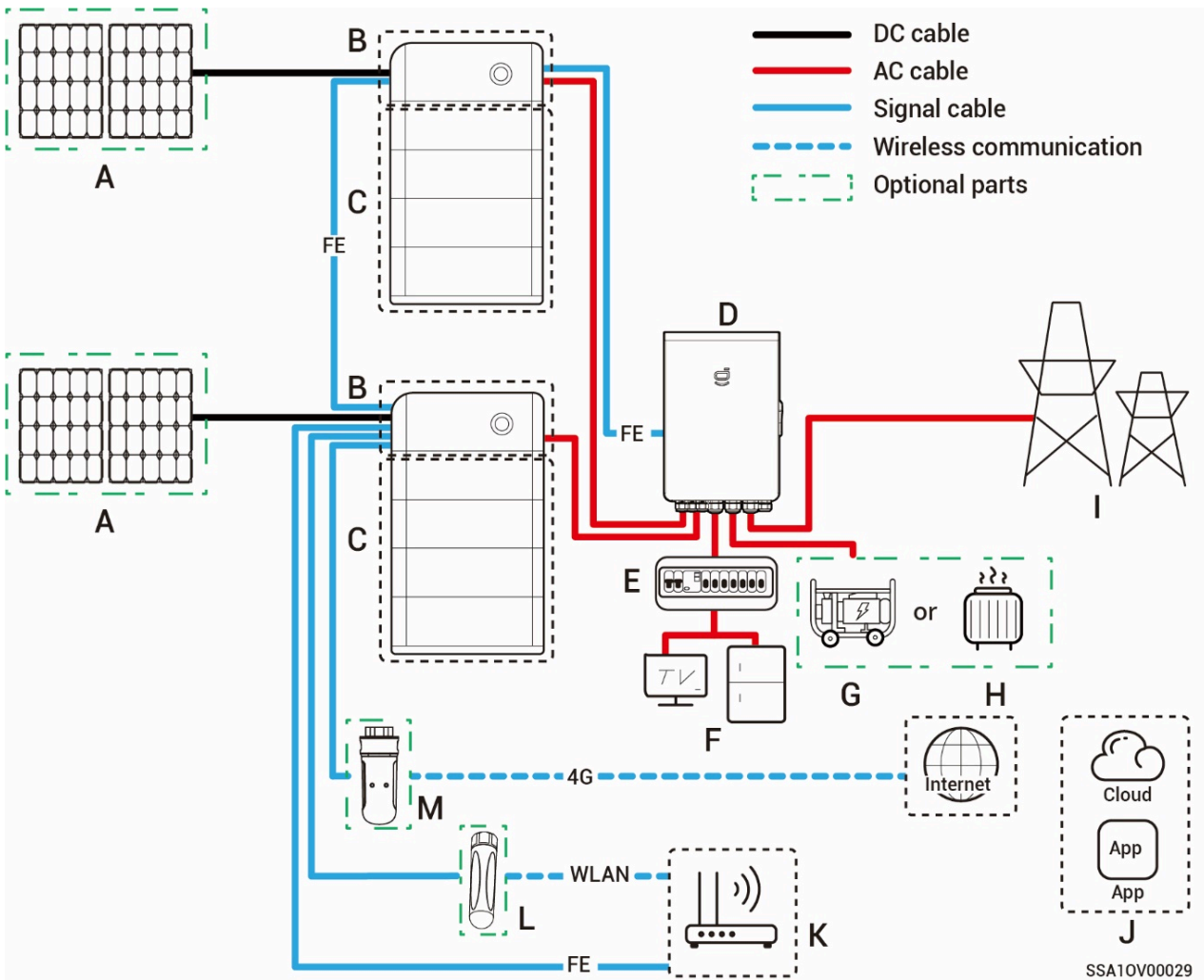

No.	Description	No.	Description	No.	Description
A	PV panel	B	SigenStor EC	C	SigenStor BAT
D	Gateway	E	Backup Distribution panel	F	Backup Household loads
G	Diesel generator	H	Smart loads	I	Power grid
J	mySigen	K	Router	L	Antenna
M	CommMod				

Tips

- No more than 20 SigenStor units can be cascaded.
- If F (backup household loads) experiences leakage, it may pose a risk of electric shock. In order to avoid this hazard, a residual current device (RCD) must be installed between the D (Gateway) and the F (backup household loads).
- As a backup energy source for long-term off-grid applications, the diesel generator can work in tandem with the Gateway to provide a smooth transition between PV, storage and diesel power generation.
- All the power equipment in the owner's home can be connected as smart loads. To ensure that this product maximizes the benefits to users, it is recommended that the high-power equipment be connected as smart loads (heat pumps, pool heaters, clothes dryers, immersion heaters, etc.), which can be cut off when the energy storage system has low power. Other low-power equipment are connected as home loads (lights, routers, etc.) The maximum power for an immersion heater should be $\leq 17.6 \text{ kW}/80 \text{ A}$.
- It is recommended to use Fast Ethernet and WLAN for communication with inverters. If 4G communication is used, you must purchase Sigen CommMod separately. When free 4G traffic of CommMod runs out, users must top up their accounts or replace an SIM card.

Networking Diagram (Partial Home Backup)

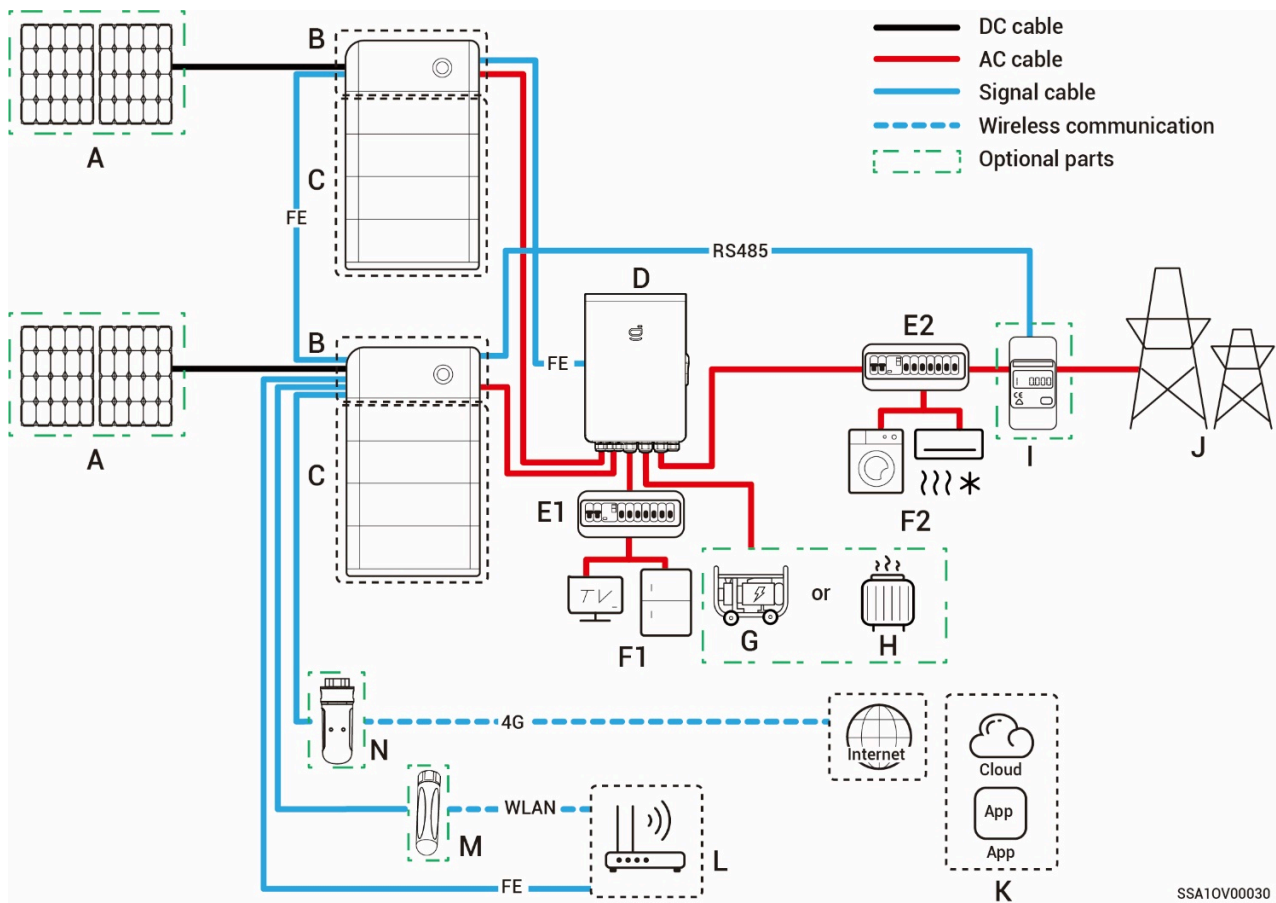

No.	Description	No.	Description	No.	Description
A	PV panel	B	SigenStor EC	C	SigenStor BAT
D	Gateway	E1	Backup Distribution panel	E2	Non-Backup Distribution panel
F1	Backup Household loads	F2	Non-Backup Household loads	G	Diesel Generator
H	Smart loads	I	Power sensor	J	Power grid
K	mySigen	L	Router	M	Antenna
N	CommMod				

Tips

- No more than 20 SigenStor units can be cascaded.
- If E2 (non-backup distribution panel) features leakage protection, it is recommended that the rated residual operating current be greater than or equal to the number of inverters × 100 mA.
- If F1 (backup household loads) experiences leakage, it may pose a risk of electric shock. In order to avoid this hazard, a residual current device (RCD) must be installed between the D (Gateway) and the F1 (backup household loads).
- As a backup energy source for long-term off-grid applications, the diesel generator can work in tandem with the Gateway to provide a smooth transition between PV, storage and diesel power generation.
- All the power equipment in the owner's home can be connected as smart loads. To ensure that this product maximizes the benefits to users, it is recommended that the high-power equipment be connected as smart loads (heat pumps, pool heaters, clothes dryers, immersion heaters, etc.), which can be cut off when the energy storage system has low power. Other low-power equipment are connected as home loads (lights, routers, etc.) The maximum power for an immersion heater should be $\leq 17.6 \text{ kW}/80 \text{ A}$.
- Power sensor has the function of data acquisition for grid connection points enables zero-power grid connection. For partial home backup, Power sensor does not need to be configured. For partial backup power and zero-power grid connection control networking, Power sensor is configured.
- It is recommended to use Fast Ethernet and WLAN for communication with inverters. If 4G communication is used, you must purchase Sigen CommMod separately. When free 4G traffic of CommMod runs out, users must top up their accounts or replace an SIM card.

Networking Diagram (Non-backup Networking)

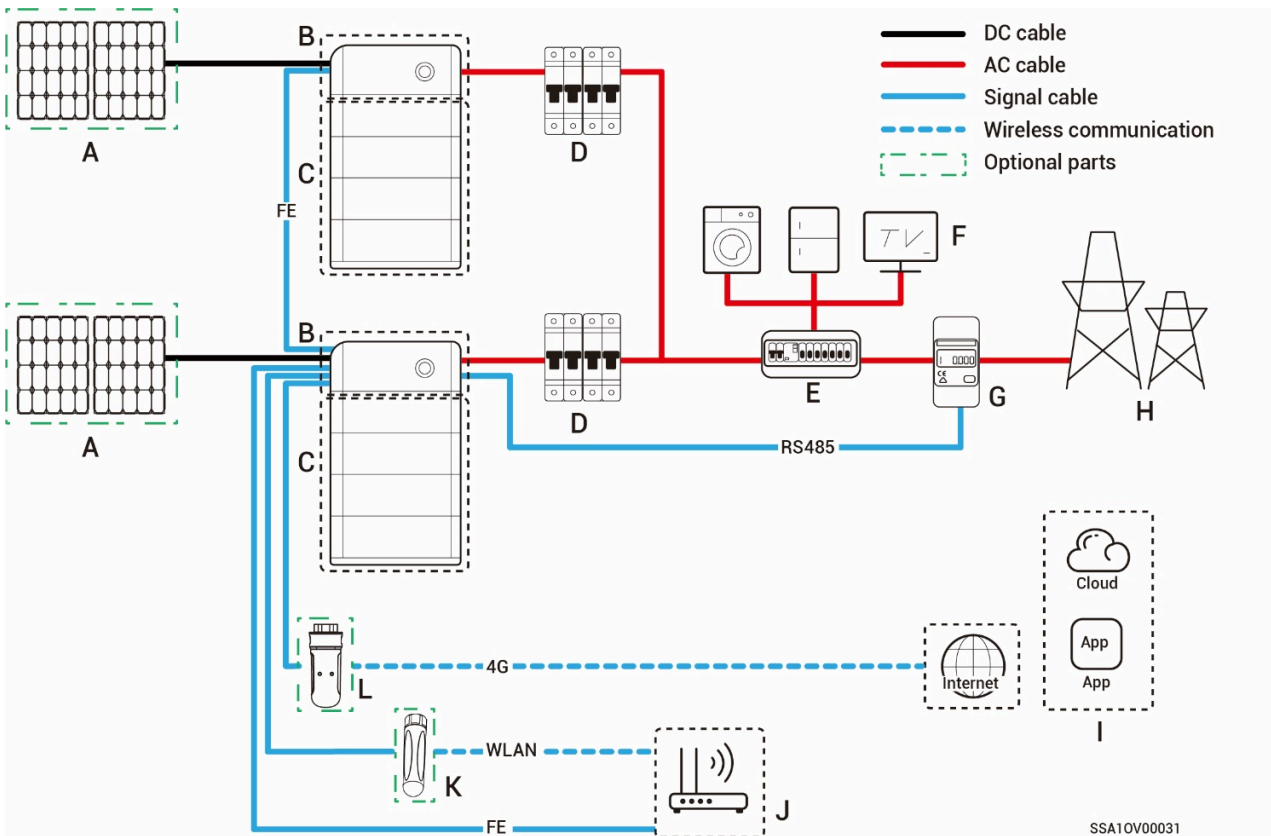

No.	Description	No.	Description	No.	Description
A	PV panel	B	SigenStor EC	C	SigenStor BAT
D	AC switch	E	Distribution panel	F	Household loads
G	Power sensor	H	Power grid	I	mySigen
J	Router	K	Antenna	L	CommMod

Tips

- No more than 20 SigenStor units can be cascaded.
- **SigenStor-(5S, 6S) Series:** the rated voltage of the AC switch connected to each inverter should be ≥ 240 Va.c. and the rated current is 40 A.
- **SigenStor-(8S-12S) Series:** the rated voltage of the AC switch connected to each inverter should be ≥ 240 Va.c., and the rated current is recommended:
 - SigenStor-8S Series: The rated current is 50 A

- SigenStor-(10S-12S) Series: The rated current is 60 A
- **SigenStor-(5T-30T) Series:** the rated voltage of the AC switch connected to each inverter should be ≥ 380 Va.c., and the rated current is recommended:
 - SigenStor-5T Series: The rated current is 25 A
 - SigenStor-(10T-15T) Series: The rated current is 32 A
 - SigenStor-20T Series: The rated current is 40 A
 - SigenStor-25T Series: The rated current is 50 A
 - SigenStor-30T Series: The rated current is 63 A
- If E (distribution panel) features leakage protection, it is recommended that the rated residual operating current be greater than or equal to the number of inverters \times 100 mA.
- It is recommended to use Fast Ethernet and WLAN for communication with inverters. If 4G communication is used, you must purchase Sigen CommMod separately. When free 4G traffic of CommMod runs out, users must top up their accounts or replace an SIM card.
- **SigenStor-(5S, 6S) & SigenStor-(8S-12S) Series:** the rated voltage of the AC switch of the distribution panel should be not less than 240 Va.c., and the rated current is recommended, that is, not less than the maximum output current of an inverter \times the number of inverters in parallel connection $\times 1.25$ ^[1].
- **SigenStor-(5T-30T) Series:** the rated voltage of the AC switch of the distribution panel should be not less than 380 Va.c., and the rated current is recommended, that is, not less than the maximum output current of an inverter \times the number of inverters in parallel connection $\times 1.25$ ^[1].

Note [1]: The maximum output current of an inverter can be found in its respective data sheet.

Site Selection Requirements

Tips

- The equipment can be installed indoors and outdoors. Install the equipment in strict accordance with installation instructions given in this section and local laws and regulations.
- Before installing the equipment, please be sure to carefully read the following installation requirements. The company will not be liable for any functional abnormalities or damages arising from the operation of the equipment if the installation requirements are not followed, even in cases leading to personal safety incidents.
- During actual installation, the selection of installation location should comply with local firefighting, environmental protection regulations, and other relevant laws. The specific installation location planning should be subject to the installer or engineering, procurement, and construction (EPC) contracts.

Installation Environment Requirements

- Do not install the equipment in smoky, flammable, or explosive environments.
- Avoid exposing the equipment to direct sunlight, rain, standing water, snow, or dust. It is suggested to install the equipment in a sheltered place. Take preventive measures in operating areas prone to natural disasters such as floods, mudslides, earthquakes, and typhoons.
- Do not install the equipment in an environment with strong electromagnetic interference.
- The temperature and humidity of the installation environment should meet equipment requirements.
- The equipment should be installed in an area that is at least 500 m away from corrosion sources that may result in salt damage or acid damage. Corrosion sources include but are not limited to seaside, thermal power plants, chemical plants, smelters, coal plants, rubber plants, and electroplating plants.

- In areas with good marine environments (such as Norway, where the nearshore salinity is ≤ 28 psu), the mounting distance of the device from the coastline can be appropriately relaxed to ≥ 200 m.
- If the outer surface of the device is damaged, please repaint the device in time.

Installation Position Requirements

- Do not tilt the equipment or place it upside down. Ensure that the equipment is horizontally installed.
- Do not install the equipment in places easily touched by children.
- Do not install the equipment in a place with fire hazards or is prone to moisturizing.
- The equipment produces sound when it is operating. Please install the equipment in a place with appropriate distance at which there is no impact to daily work and life.
- Do not install the equipment in a sealed, poorly ventilated location without fire protection measures and inaccessible for firefighters.
- The equipment is hot when it is operating. If the equipment is installed indoors, please ensure good indoor ventilation and avoid significant indoor temperature rise by more than 3°C while the equipment is operating. Otherwise, the equipment will be derated.
- Do not install the equipment in mobile scenarios such as recreational vehicles, cruise ships, and trains.
- It is recommended to install the equipment in a location where you can easily access, install, operate, and maintain it, and view the indicator status.
- Do not place the equipment in the vehicle passage when installed in a garage to avoid collisions.

Mounting Surface Requirements

- Do not install the equipment on a flammable base. If this cannot be avoided, add a fire barrier between the equipment and the flammable base.

- The installation base should meet the load-bearing requirement. Solid brick-concrete structures, concrete walls, and floors are recommended.
- The installation base should be flat, and the installation area should meet the installation space requirements.
- No plumbing or electrical alignments are allowed inside the installation base to avoid potential drilling hazards during equipment installation.

Tips

To ensure optimal performance of the device, it is suggested that the installation distance between the device and surrounding obstacles be planned with reference to the diagram. If the installation site is well-ventilated, the optimal solution may be deployed based on actual conditions.

≤ 12.0kW Models Installation Recommendations

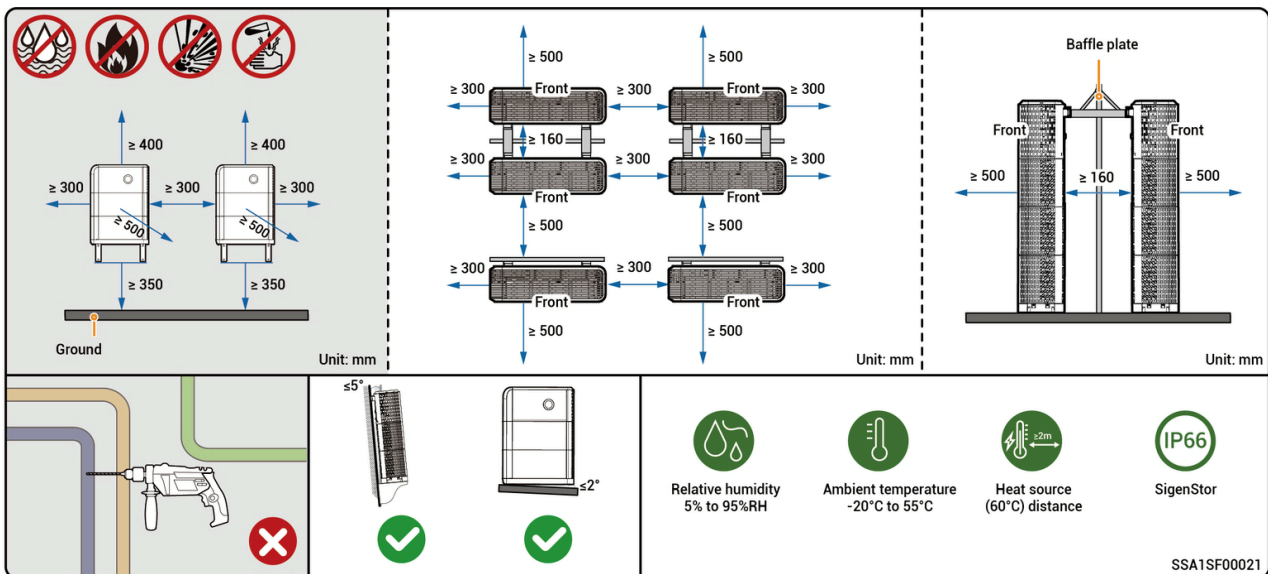

> 12.0kW Models Installation Recommendations

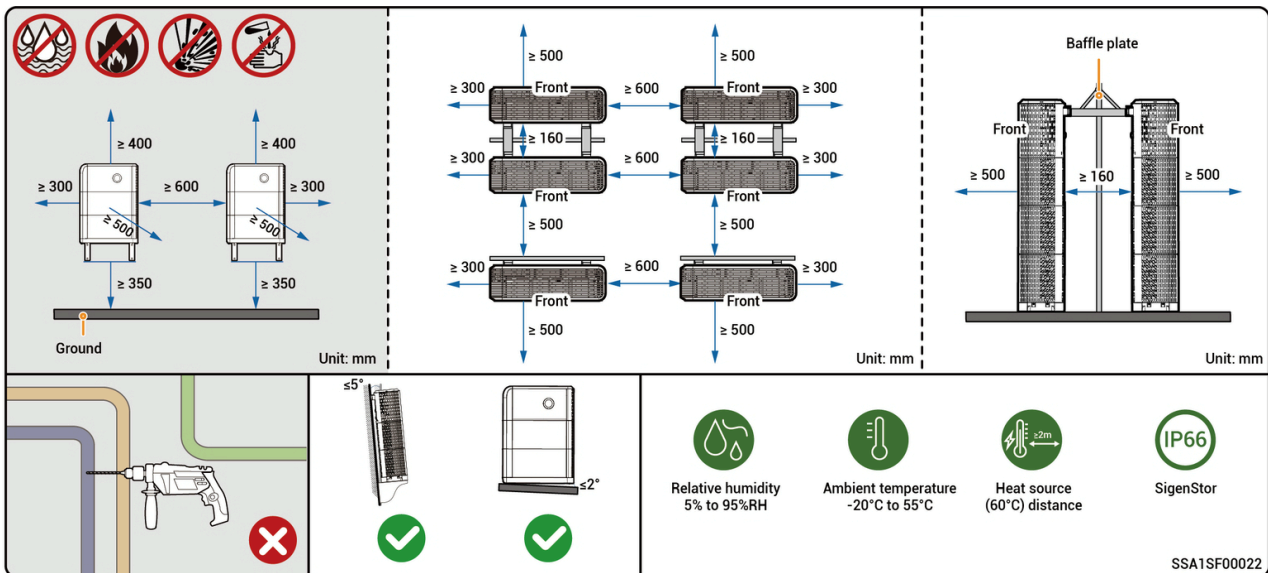

With SigenStor EVDC Series

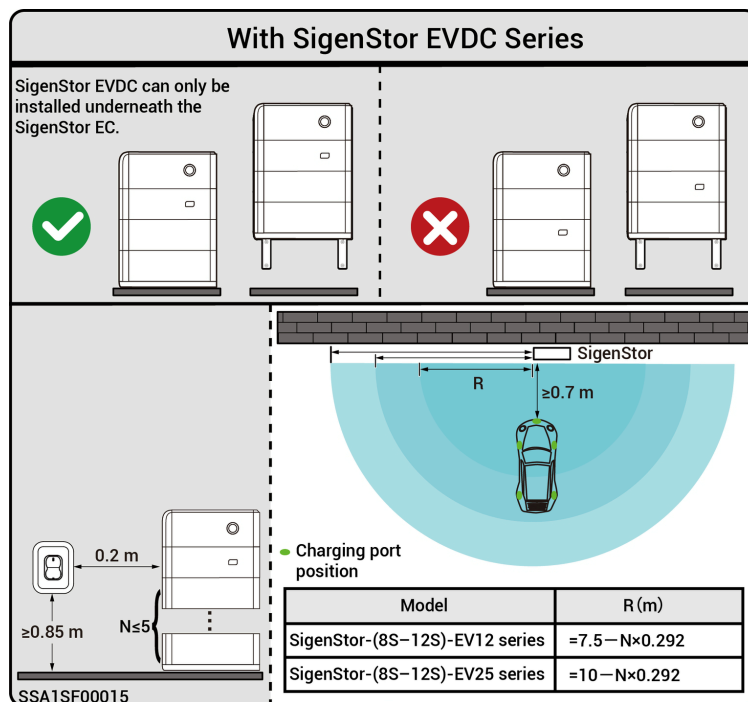

Tips

- For models with SigenStor EVDC series, please install it near the parking space. For installation distance, refer to the illustrations.
- There will be errors in the actual distance under different installation environments, and the figure is for reference only.

- The maximum operating temperature range applicable to the equipment is -20°C to 55°C , and the recommended optimal operating temperature range is $10^{\circ}\text{C} \leq T \leq 35^{\circ}\text{C}$.
- When the battery pack temperature is below 0°C , immediate charging is not possible, and the battery pack (the built-in heating module can be automatically enabled) will activate the heating feature automatically. The best charging performance of the battery can be achieved after heating for less than 2h. The heating feature will consume power.
- At a temperature $> 40^{\circ}\text{C}$, the operation of the equipment may trigger a power derating that prevents the equipment from operating optimally. The higher the temperature, the shorter the service life of the equipment.

Equipment Installation and Wiring

- Only company authorized personnel should install and connect the equipment. For details, see the ***Installation Guide*** of its respective model.
- Parts and accessories supplied with the packing box are personal assets of the owner and must be kept safe.

System Operation

Working Mode

Tips

The energy storage system supports multiple working modes, Some countries support Load Shedding Mode and VPP Scheduling-evergen Mode, which is subject to the App interface display.

Sigen AI Mode

By obtaining local peak and valley electricity prices and weather data, combined with user electricity consumption habits, the Sigen AI Mode can customize intelligent electricity usage solutions to maximize customers' cost savings.

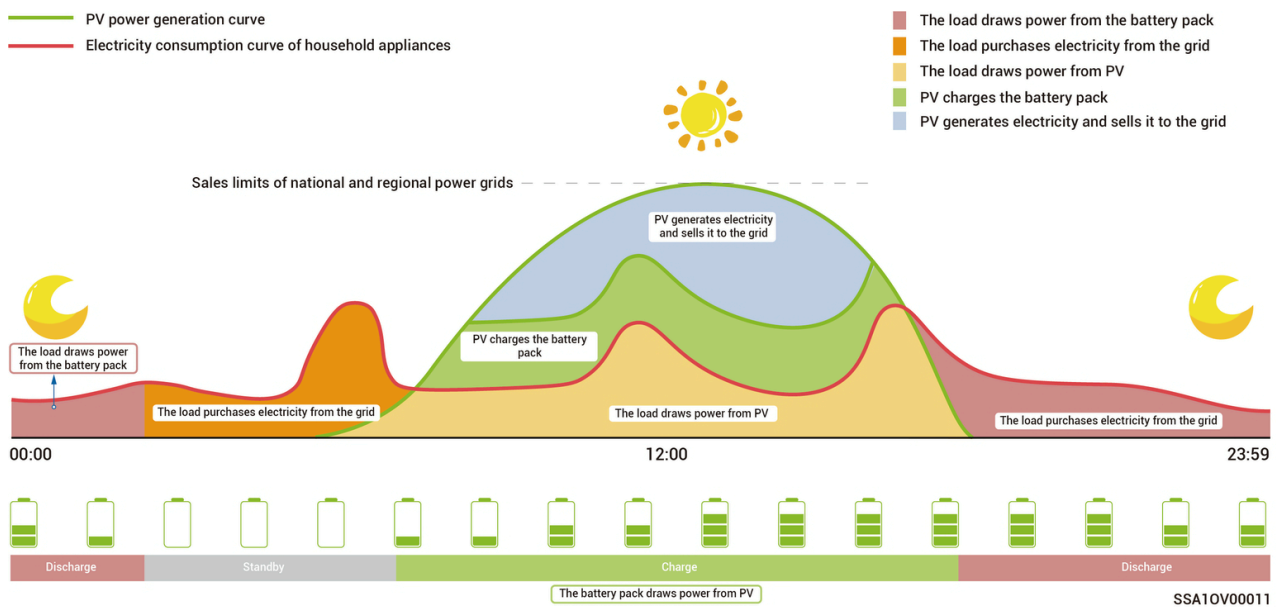

Self-Consumption Mode

- When there is sufficient solar power, the electric energy generated by the PV system will first be used to power the loads, with any excess energy being stored in the batteries. Any remaining surplus energy will be sold to the grid. When there is insufficient solar power, the batteries will release electric energy to loads. By increasing the self-consumption ratio of the PV system and improving the self-sufficiency ratio of household energy, you can effectively save on your electric bills.
- This mode is suitable for areas with high electricity prices or zero-power grid connection restrictions.

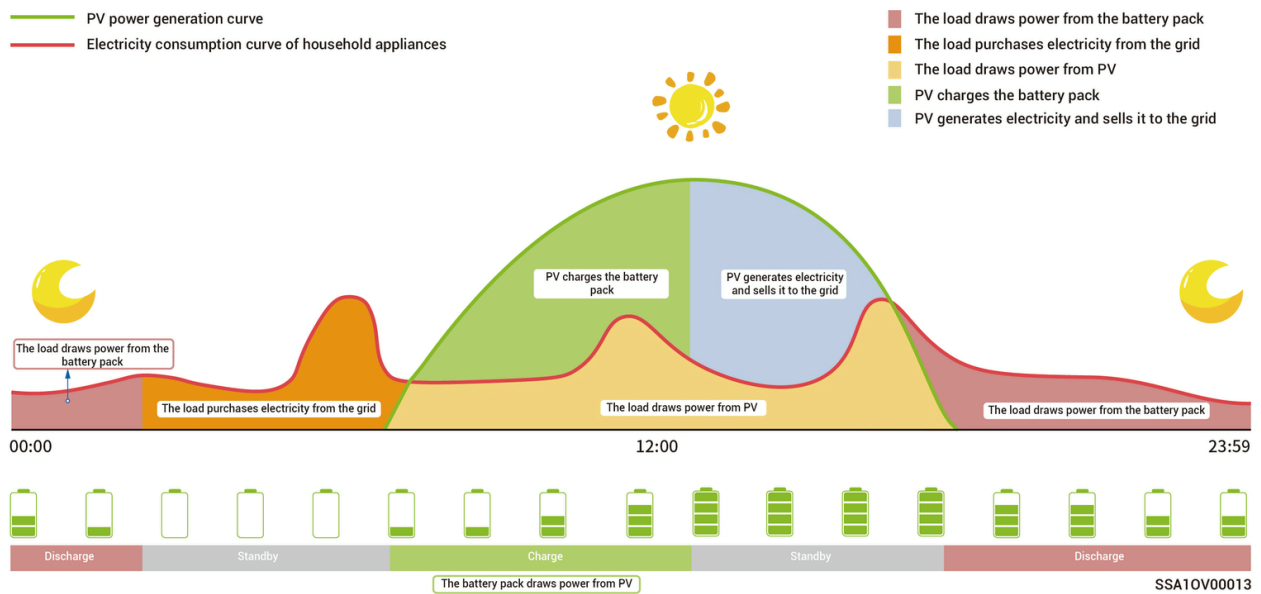

Time-based Control Mode

- The charging period, discharging period, and self-consumption period need to be set manually. When electricity prices are high, the surplus power from photovoltaic power generation and battery power can be sold to the grid, and the battery can be charged during periods of low electricity prices to save electricity bills.
- If no period is set, the energy storage system will be in standby mode without discharging. The photovoltaic power will prioritize supplying the load, and the surplus power will be used for charging energy storage system.*
- Up to 24 charging and discharging or self-consumption periods can be set.
- It is suitable for areas with peak and valley electricity prices and significant price differences.

*When entering this period, the battery capacity will be recorded. When the photovoltaic power is greater than the load, the remaining photovoltaic power will charge the battery. When the photovoltaic power is less than the load, the battery can be discharged to the load. However, when the battery capacity decreases and approaches the battery capacity value when entering this period, the battery will stop discharging.

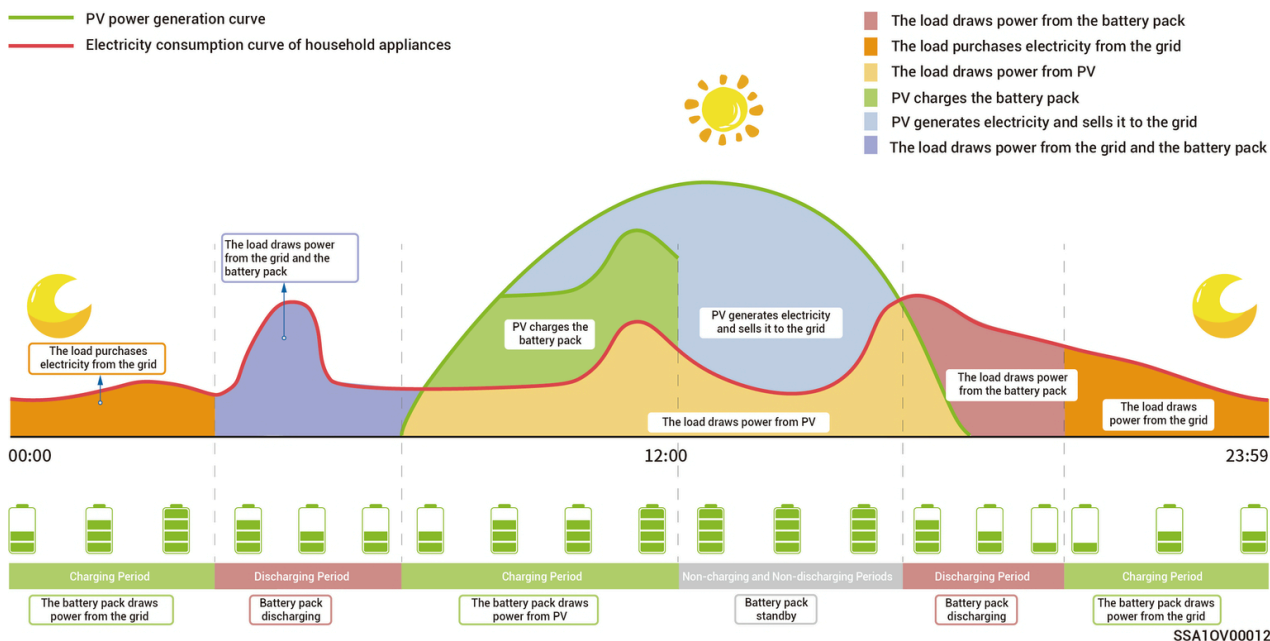

Fully Fed to Grid Mode

- You can sell excess energy back to the grid and earn credits on your energy bill.
- In the daytime, when the PV power is greater than the maximum output capacity of the inverter, the inverter maintains the maximum output while storing excess energy in the batteries. When the PV power is lower than the maximum output capacity of the inverter or there is no PV power in the nighttime, the batteries are discharged to ensure that the inverter maximizes the output.

Remote EMS Mode

After setting to this mode, a third-party EMS dispatch company will be allowed to set the relevant parameters of the power station and products. Do not enter or exit this mode without the installer's confirmation.

Load Shedding Mode

In areas with frequent power outages, you can add your region and schedule in this mode, and the system will fully charge the battery in advance as scheduled, ensuring that you have battery power available to supply the load during outages. (currently only supported in South Africa)

VPP Scheduling-evergen Mode

Once registered with the VPP, your storage system will join the smart dispatching network. The App will show and auto-enable this mode.

Backup power setup

Tips

- Skip this section if no Gateway is configured.
- Users can manually set this parameter according to the power interruption frequency of their regions and leave time.

If there is a gateway in your networking, you can manually set the "Backup Reserve" value in the mySigen App. In grid connection mode, the battery stops discharging when the backup power SOC setting is reached. In the event of grid power outage, the backup power becomes available.

For example, the backup power SOC is set in Self-Consumption Mode.

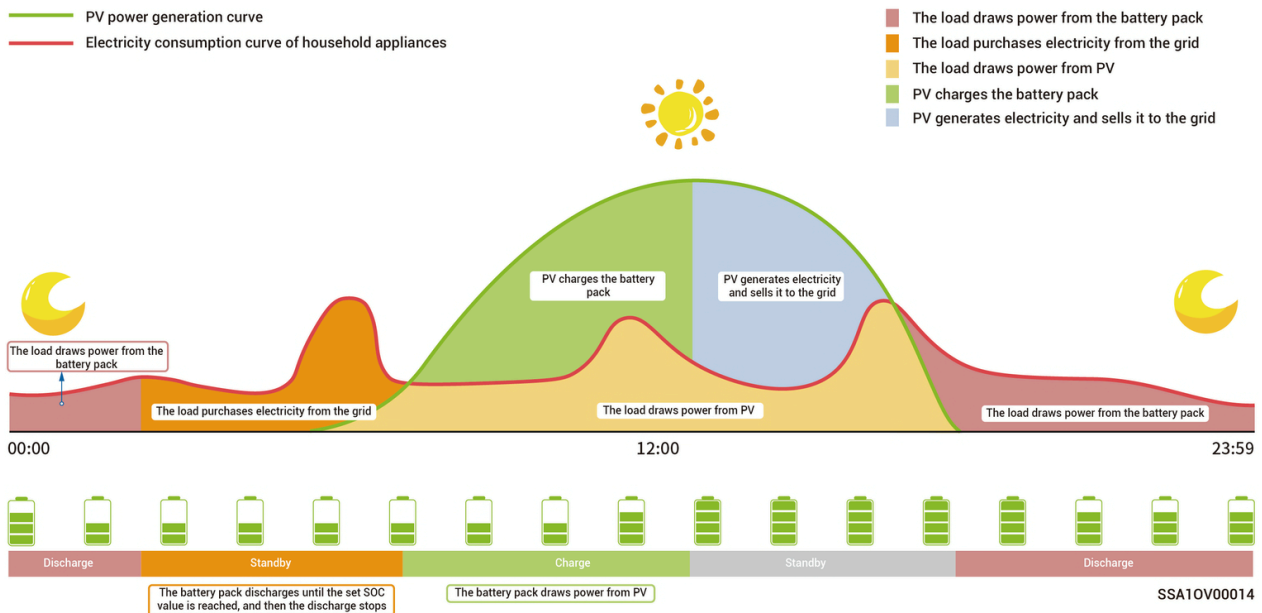

Peak Shaving Control Mode

- The electricity bill in some regions is calculated as follows: Total electricity bill = Cost at peak power + cost for electricity usage + other costs. Wherein, peak power refers to the maximum power imported from the grid. This mode is suitable for areas with peak and valley electricity prices and significant price differences.
- The Peak Shaving function can be used with all working modes, configuring the maximum peak power drawn from the grid to reduce the maximum peak power drawn from the grid during peak periods, thereby lowering the electricity bill.

Example 1: Self-Consumption Mode Settings for Peak Shaving

Assume that the peak shaving SOC is set to 50% and the maximum peak power is 2kW. Because Total electricity bill = Cost at peak power + cost for electricity usage + other costs. Wherein, peak power refers to the maximum power imported from the grid. After Self-Consumption Mode is set to Peak Shaving, the power purchased from the grid drops from 5 kW to 2 kW, so the total electricity bill is reduced.

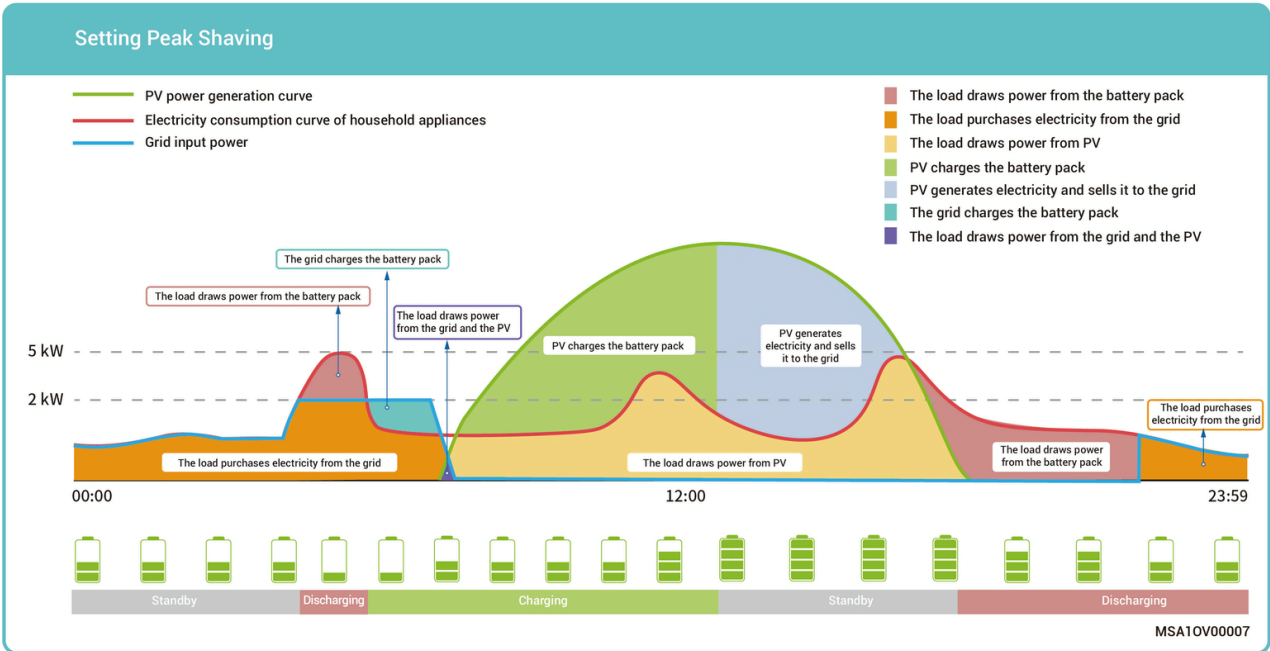
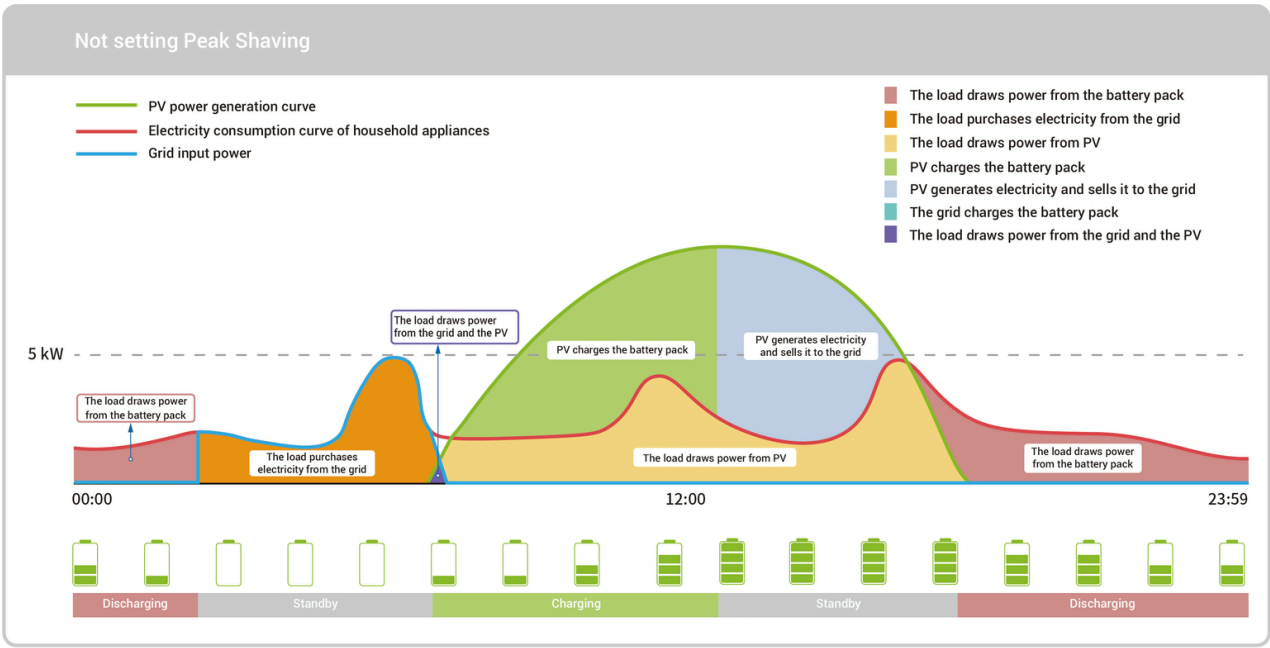

Example 2: Time-based Control Mode Settings for Peak Shaving

Assume that the peak shaving SOC is set to 50% and the maximum peak power is 2kW. Because Total electricity bill = Cost at peak power + cost for electricity usage + other costs. Wherein, peak power refers to the maximum power imported from the grid. After Time-based Control Mode is set to Peak Shaving, the power purchased from the grid drops from 5 kW to 2 kW, so the total electricity bill is reduced.

Not setting Peak Shaving

- PV power generation curve
- Electricity consumption curve of household appliances
- Grid input power

- The load draws power from the battery pack
- The load purchases electricity from the grid
- The load draws power from PV
- PV charges the battery pack
- PV generates electricity and sells it to the grid
- The grid charges the battery pack
- The load draws power from the grid and the battery pack
- The load draws power from the grid and the PV

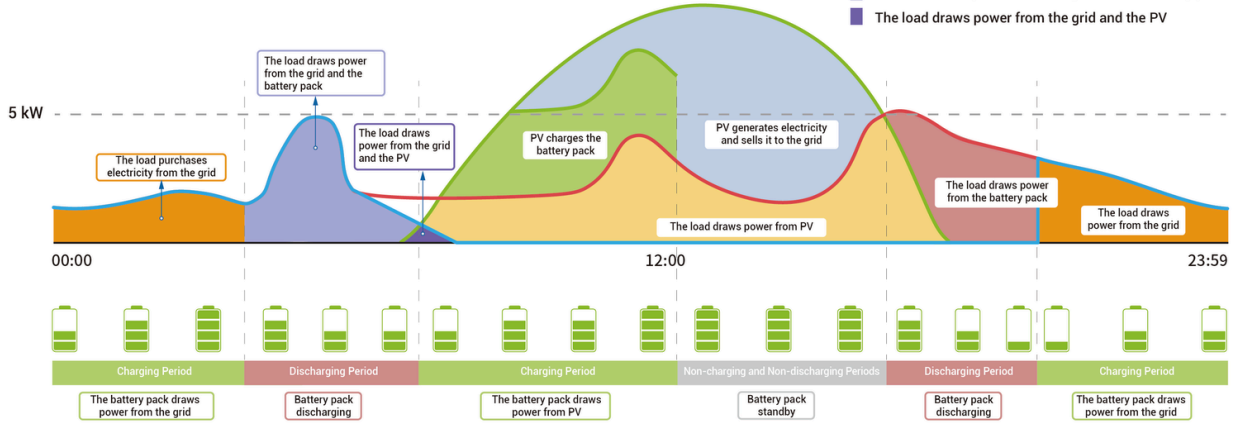

Setting Peak Shaving

- PV power generation curve
- Electricity consumption curve of household appliances
- Grid input power

- The load draws power from the battery pack
- The load purchases electricity from the grid
- The load draws power from PV
- PV charges the battery pack
- PV generates electricity and sells it to the grid
- The grid charges the battery pack
- The load draws power from the grid and the PV

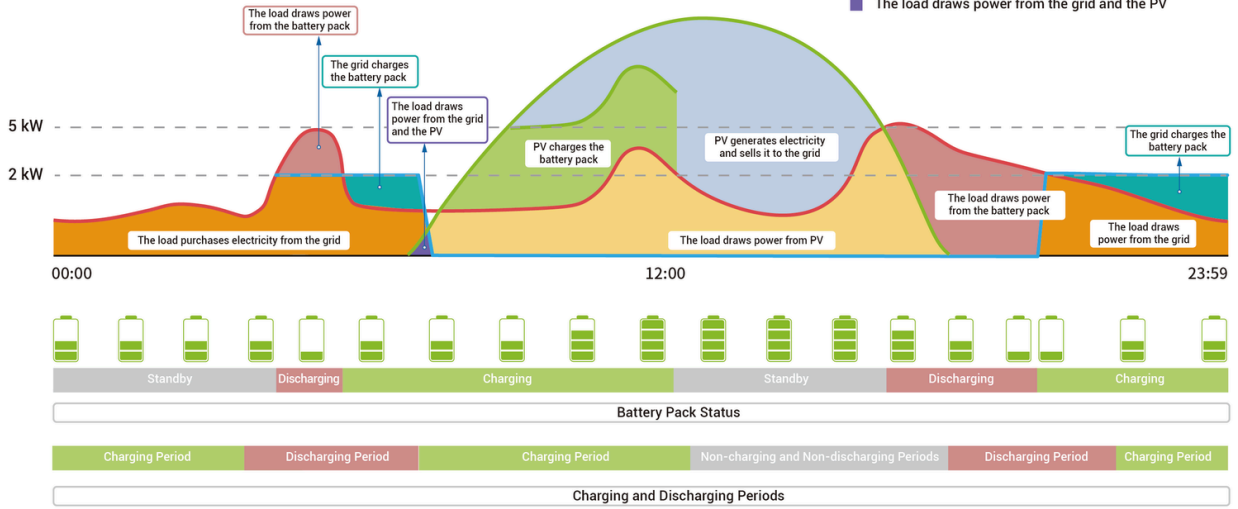





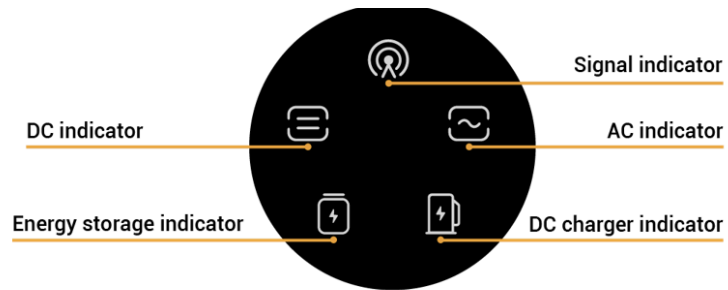



















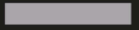

MSA1OV00008

LED Indicator State

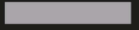

SSA1IN00027

Indicator	Color	State	Description
		Always on	The DC side is connected but not running.
		Always on	The DC side is running.
		-	The DC side is not connected.
		Flash	The DC side is faulty.
		Always on	Inverter failure.
		Always on	The AC side is connected but not running.
		Always on	Grid-connected operation.
		Always on	Off-grid operation.
		-	The AC side is not connected.
		Flash	Off-grid overload operation.
		Flash	The AC side is faulty.
		Always on	Inverter failure.
		Always on	All SigenStor BATs are connected but not running.
		Flash	SigenStor BAT is charging.
		Flash	SigenStor BAT is discharging.
		-	All SigenStor BATs lie dormant.
		Flash	Some SigenStor BATs are faulty.
		Always on	All SigenStor BATs are faulty.
		Off	The management system is not connected.
		Flash	Connected to local App.
		Always on	Connected to the management system using an FE or WLAN.
		Always on	Connected to the management system over 4G.
		Flash	Insufficient traffic for Sigen CommMod.

mySigen App Query and Settings

The App can be downloaded in the following two ways. For details, see *mySigen App User Manual*.

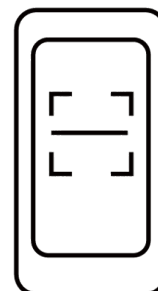

SSA1CM00014

System Maintenance

Routine Maintenance

To ensure the long-term running of the equipment, you are advised to perform routine maintenance according to this section.

Inspection content	Inspection method	Power off or not	Maintenance cycle
System cleaning	Check the decorative cover regularly for shielding and dirt. If so, clean it up. Do not use tools that may cause electric shock or insulation damage, such as wire brushes during the cleaning process.	Yes	Once every three months.
System running state	<ul style="list-style-type: none"> • Check whether the equipment is damaged or deformed. • Listen for any abnormal noises during the operation of the equipment. • When the equipment is running, check whether the equipment parameters are correctly set. 	No	Once every six months

-

System Power-on/Power-off

Danger

High Voltage and Hazards: Wear personal protective equipment such as insulating gloves, insulating shoes, and safety hats while operating the equipment. Do not wear conductive accessories such as metal bracelets, rings, or necklaces.

System power-off

1. Power the equipment off in the App or manually.

App operation

Tap "Setting" in mySigen App to turn on/off the device.

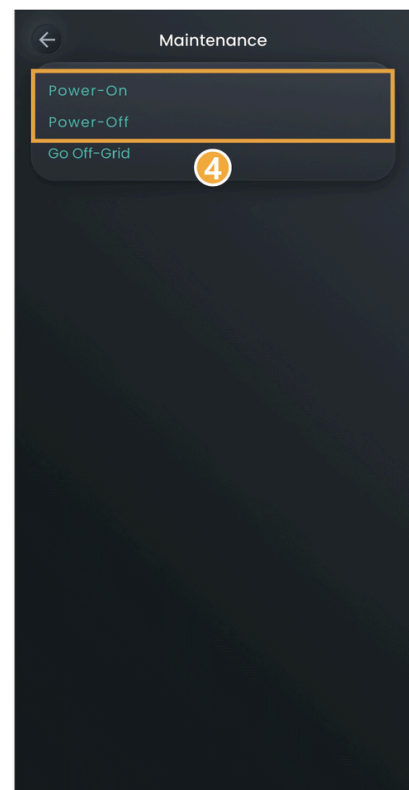
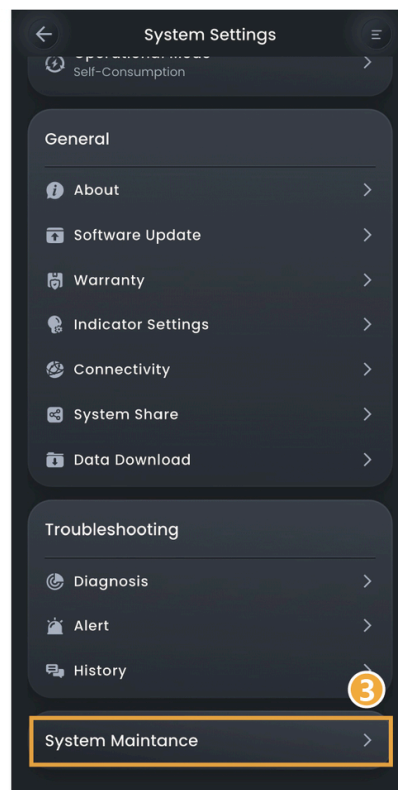

Manual operation

Follow the steps shown to remove the side and top decorative cover, and press the ON/OFF switch button.

Tips

Press and hold for more than 3s to turn on or off the power; an interval of more than 10s is needed between power-on and power-off.

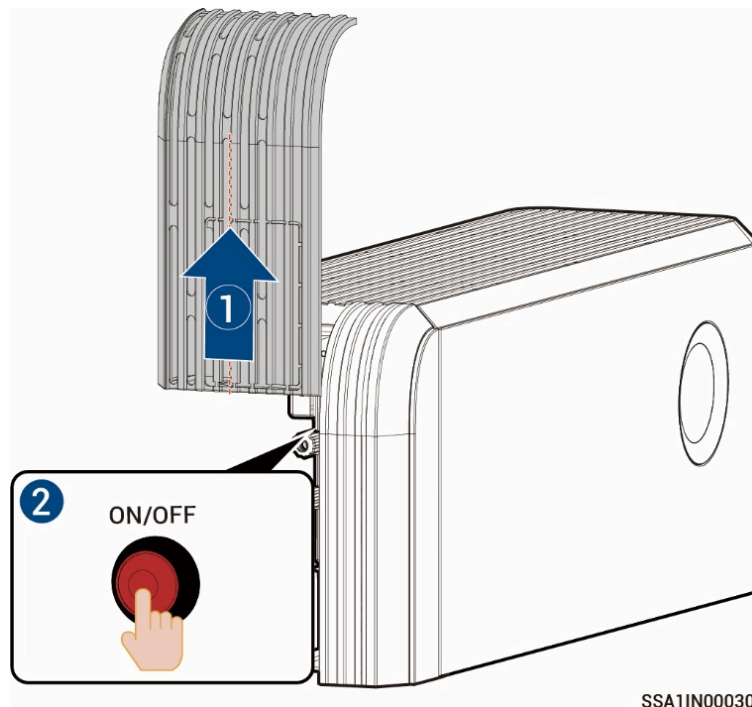

Tips

Major firmware upgrades can fail if the equipment is not connected to the internet for an extended period of time. When your device is not connected to the internet, the system issues periodic notifications. If the disconnection persists beyond 90 consecutive days, the system will automatically engage in safe operating mode for safety compliance. Reconnect to the internet immediately. For unresolved issues, feel free to contact us.

2. Turn off the switch connected to the equipment in the backup power distribution panel.
3. Turn DC SWITCH on the equipment to the OFF position.

4. After all LED indicators on the equipment go off, wait for the corresponding time as indicated on the label on the equipment before proceeding.

 **Warning**

There is residual current and the equipment is hot immediately after the equipment is powered off. Operating the equipment immediately upon power off may lead to electric shock or burns.

System power-on

1. Turn DC SWITCH on the equipment to the ON position.
2. Turn on the switch connected to the equipment in the backup power distribution panel.
3. Power the equipment on in the App or manually. For details, see Step 1 in System power-off.

Low SOC

The self-discharge characteristic of battery pack will cause power loss. If the equipment is not charged for a long time, it may be damaged due to overdischarge of power. When the battery is low, charge the equipment in time. Under normal circumstances, the equipment can charge itself according to the running condition. If the equipment cannot be charged, please contact your sales agent in time and deal with it within the specified time. If the battery capacity is lost or irreversible damage is caused due to the delay, the company will not be liable.

- When the battery power is greater than or equal to 10%, charge within 30 days
- When the battery power is less than or equal to 0% and less than 10%, charge within 7 days

Scenarios that may cause a charge failure (including but not limited to) :

- The PV side has no input, and the power grid side is powered off for a long time.
- The equipment is faulty.
- Parameters are not set correctly.

Emergency Treatment

Emergency Measures for Fire

Danger

- Please shut down the equipment or disconnect the main power switch when it is safe.
- The high temperature may distort or damage the battery pack, resulting in electrolyte overflow or toxic gas leakage. Do not go near the battery pack and wear protective equipment.
- If the fire is small, use carbon dioxide or ABC dry powder extinguisher to extinguish the fire.
- If the fire is spreading, evacuate the building or equipment area immediately and call the fire department. Re-entry to burning buildings is prohibited.
- Do not contact with high voltage components during fire fighting, otherwise it may lead to the risk of electric shock.
- After extinguishing the fire, do not use the equipment, please contact your installer or sales agent.

Emergency Measures for Flood

Danger

- Please shut down the equipment or disconnect the main power switch when it is safe.
- If the battery pack is submerged, do not touch it to avoid the danger of electric shock.
- After the flood waters recede, do not use the equipment. Please contact your installer or sales agent.

Emergency Measures for Battery Pack Exceptions

Danger

- When the battery pack has abnormal odor, electrolyte leakage, or heat, do not touch it, and contact professional personnel immediately. Professionals must wear protective equipment such as goggles, rubber gloves, gas masks, and protective clothing to protect themselves.
- The electrolyte is corrosive and contact may cause skin irritation or chemical burns. In case of accidental contact with electrolyte, take the following measures immediately:
 - Inhalation: Evacuate the contaminated area, keep fresh air circulating, and seek immediate medical help.
 - Eye contact: Flush eyes with plenty of water for at least 15 minutes. Do not rub eyes. Seek medical help immediately.
 - Skin contact: Wash the contact area with plenty of soapy water and seek medical help immediately.
 - Ingestion: Induce vomiting and seek medical help immediately.
- Do not continue to use abnormal battery packs, please contact your installer or sales agent.

Emergency Measures for Battery Pack Drops or Impacts

- If there is an obvious odor, smoke, or fire, keep away from the equipment immediately and contact professional personnel.
- Do not use the battery pack if it has been dropped or hit. Please contact your installer or sales agent.

Technical Parameter

Item	SigenStor 5S-(5-16)	SigenStor 5S-(8-24)	SigenStor 5T Series	SigenStor 10T Series	SigenStor 15T Series	SigenStor 20T Series
Pollution degree	PD2, PD3	PD2, PD3	PD3	PD3	PD3	PD3
Back feed current	0 A	0 A	0 A	0 A	0 A	0 A
Inrush current	21.7 A	28.7 A	7.25	14.49	21.74	31.8
Max. output overcurrent protection	32.5 A	43.0 A	8.36	16.71	25.07	33.0
Max. output fault current	65.0 A	86.0 A	76	76	76	76

For other parameters of the equipment, please refer to their respective data sheets.

FAQs

How to upgrade SigenStor EVDC from 12 kW to 25 kW?

Purchase and activate a license. For specific operation methods, please refer to the chapters "How to Purchase a License?" and "How to Activate a License?" in the *mySigen App User Manual*.