



Powerwall 3 Installation Manual

with Backup Gateway 2

Notices

For the latest Powerwall 3 installation documents in all supported languages, visit:

www.tesla.com/support/powerwall

To secure the full 10-year product warranty, Powerwall 3 must be registered by completing the device setup process and sending system information to Tesla.

Product Specifications

All specifications and descriptions contained in this document are verified to be accurate at the time of printing. However, because continuous improvement is a goal at Tesla, we reserve the right to make product modifications at any time.

The images provided in this document are for demonstration purposes only. Depending on product version and market region, details may appear slightly different.

Errors or Omissions

To communicate any inaccuracies or omissions in this document, reach out to your Tesla Account Manager.

©2024 TESLA, INC. All rights reserved.

All information in this document is subject to copyright and other intellectual property rights of Tesla, Inc. and its licensors. This material may not be modified, reproduced or copied, in whole or in part, without the prior written permission of Tesla, Inc. and its licensors. Additional information is available upon request. The following are trademarks or registered trademarks of Tesla, Inc. in the United States and other countries:

		Tesla	Tesla Motors	Powerwall
--	---	-------	--------------	-----------

All other trademarks contained in this document are the property of their respective owners and their use herein does not imply sponsorship or endorsement of their products or services. The unauthorized use of any trademark displayed in this document or on the product is strictly prohibited.

Electronic Device: Do Not Throw Away

Proper disposal of batteries is required. Refer to local codes for disposal requirements.

For Private Households: Information on Disposal for Users of WEEE

This symbol on the product(s) and / or accompanying documents means that Waste from Electrical and Electronic Equipment (WEEE) should not be mixed with general household waste. For proper treatment, recovery and recycling, please take this product(s) to designated collection points where it will be accepted free of charge. Alternatively, in some countries, you may be able to return your products to your local retailer upon purchase of an equivalent new product.

Disposing of this product correctly will help save valuable resources and prevent any potential negative effects on human health and the environment, which could otherwise arise from inappropriate waste handling.

Please contact your local authority for further details of your nearest designated collection point.

Penalties may be applicable for incorrect disposal of this waste, in accordance with your national legislation.

For Professional Users in the European Union

If you wish to discard electrical and electronic equipment (EEE), please contact your dealer or supplier for further information.

For Disposal in Countries Outside of the European Union

This symbol is only valid in the European Union (EU). If you wish to discard this product please contact your local authorities or dealer and ask for the correct method of disposal.

General Warnings and Information.....	3	Verify Neutral-Earth Bonding Scheme.....	49
Supported Configurations.....	5	Make AC Power Connections to Supply and Load Panels	50
Specifications.....	6	50
Powerwall 3 Specifications.....	6	Install Powerwall and Generation Breakers in the Backup	52
Backup Gateway 2 Specifications.....	11	Gateway.....	52
Registering Powerwall 3.....	12	Configuring Powerwall(s) on Three-Phase Installations...	53
Powerwall 3 Overview.....	13	53
Powerwall 3 System Design Guidance.....	14	Inverter Configuration.....	54
Design Considerations.....	14	STEP 6: Connect Powerwall 3 to Backup	55
System Sizing.....	15	Gateway.....	55
Backup Loads Supported per Powerwall Quantity.....	15	STEP 7: Connect Powerwall 3 to an	57
Powerwall 3 DC System Sizing.....	16	Overcurrent Protection Device.....	57
AC-Coupled Solar System Sizing.....	18	STEP 8: Install Clamp-on Ferrite Cores.....	61
Undersized Powerwall 3 Systems.....	19	STEP 9: Install Energy Metering for the System	63
Metering Considerations.....	19	63
Site Requirements and Pre-Installation		Install Tesla 100 A CTs.....	66
Guidance.....	21	STEP 10: Complete the Installation.....	67
Preparing for Installation.....	22	Plan Internet Connection for Powerwall.....	67
In the Powerwall 3 Box.....	22	Close Backup Gateway 2 Wiring Compartment.....	68
In the Powerwall 3 Accessory Bag.....	22	STEP 11: Turn On and Commission the System..	69
In the Backup Gateway 2 Box.....	23	69
In the Backup Gateway 2 Accessory Bag.....	23	Commission the System Ahead of Solar Installation....	70
Powerwall 3 Service Parts, Orderable Parts, and		Commission the System After Powerwall and Solar	74
Accessories.....	24	Installation.....	74
Required Tools.....	25	STEP 12: Install Powerwall 3 Front Cover.....	76
Required Supplies.....	26	STEP 13: Demonstrate the Installation.....	81
STEP 1: Plan the Installation Site.....	27	Technical Support.....	81
Choose a Location that Meets Powerwall 3 Clearance		Maintenance.....	81
Requirements.....	27	Appendix A: Powerwall 3 Anchoring Details.....	82
Plan Powerwall 3 Mounting Configuration.....	29	82
Plan Cable Length Between Components.....	29	General Anchoring Notes.....	82
Choose Powerwall Cable Entry.....	30	Anchoring Details for Ground- or Wall-mounting	82
Plan Amount and Size of Conduit or Raceway.....	32	Powerwall 3 with Wall Bracket on Existing Approved	82
STEP 2: Remove Powerwall 3 from Packaging		Foundation.....	82
and Transport Using the Powerwall Dolly.....	33	Appendix B: Wiring Reference.....	85
STEP 3: Wall-Mount Powerwall 3 Using Wall		Powerwall 3 AC and PV Wiring.....	85
Bracket.....	40	Tesla Asset Controller (TACO) Low Voltage and	86
STEP 4: Make Solar PV Connections.....	43	Communication Wiring.....	86
STEP 5: Install Backup Gateway 2.....	47	Prepare Ethernet Wiring with RJ45 Connectors.....	88
Mount the Backup Gateway.....	47	Backup Gateway 2 Wiring.....	89
		Backup Gateway 2 Communication Wiring.....	90

Appendix C: System Wiring Diagrams.....	92
Overview.....	92
Single-Phase Service (TN Network).....	93
Three-Phase Service (TN Network).....	94
Appendix D: (Optional) Install System	
Shutdown Switch.....	95
Appendix E: Safety Features.....	100
Powerwall 3 Switch Locking Mechanisms.....	100
Arc Fault Detection and Protection.....	101
Protective Earth Impedance Check.....	102
System LED Behavior.....	103
Powerwall 3 LED Behavior.....	103
Appendix F: Installations with Multiple	
Powerwall 3 Units.....	105
Appendix G: Shutting Down Powerwall 3.....	110
Appendix H: Troubleshooting.....	111
Situations in Which Powerwall 3 Stops Grid Forming..	111
Appendix I: Revision History.....	112



GENERAL WARNINGS AND INFORMATION







ATTENTION: Read this entire document before installing or using Powerwall. Failure to do so or to follow any of the instructions or warnings in this document can result in electrical shock, serious injury, or death, or can damage Powerwall, potentially rendering it inoperable.

IMPORTANT SAFETY INSTRUCTIONS

This manual contains important instructions for Powerwall 3 and Backup Gateway 2 that must be followed during installation and maintenance of the system.

 **NOTE:** On detection of abnormal condition for voltage or frequency conditions or in response to a detected unintentional island, the Tesla Powerwall system disconnects from the grid to prevent backfeed.

Symbols Used

	CAUTION: Indicates a hazardous situation which, if not avoided, could result in minor injury or damage to the equipment.		RISK OF ELECTRIC SHOCK: Indicates components that present risk of electrical shock.
	WARNING: Indicates a hazardous situation which, if not avoided, could result in injury or death.		CAUTION, RISK OF ELECTRIC SHOCK, ENERGY STORAGE TIMED DISCHARGE. Discharge time is 5 minutes from de-energization.
 NOTE:	NOTE: Indicates an important step or tip that leads to best results, but is not safety or damage related.		BIDIRECTIONAL TERMINAL: Indicates location of combined input/output connector on the equipment.
	REFER TO OPERATING INSTRUCTIONS: Indicates that user should refer to operating or installation instructions before proceeding.		PROTECTIVE CONDUCTOR TERMINAL: Indicates location of grounding connection on the equipment.

General Information

















 **WARNING:** Read this entire document before installing or using Powerwall. Failure to do so or to follow any of the instructions or warnings in this document can result in electrical shock, serious injury, or death, or may damage Powerwall, potentially rendering it inoperable.

 **WARNING:** A battery can present a risk of electrical shock, fire, or explosion from vented gases. Observe proper precautions.

 **WARNING:** Powerwall installation must be carried out only by a competent electrician who is certified by Tesla and who has been trained in dealing with low voltage electricity.



GENERAL WARNINGS AND INFORMATION

-  **WARNING:** Powerwall is heavy. Use of lift equipment is recommended.
-  **WARNING:** Use Powerwall only as directed.
-  **WARNING:** Do not use Powerwall if it is defective, appears cracked, broken, or otherwise damaged, or fails to operate.
-  **WARNING:** Before beginning the wiring portion of the installation, ensure that Powerwall is switched off, and lock out any associated circuit breakers and disconnect switches (if applicable for the installation).
-  **WARNING:** Do not attempt to open, disassemble, repair, tamper with, or modify Powerwall. Powerwall and its components are not user serviceable. Batteries in Powerwall are not replaceable. Contact Tesla Support for guidance on repairs.
-  **WARNING:** To protect Powerwall and its components from damage when transporting, handle with care. Do not impact, pull, drag, or step on Powerwall. Do not subject Powerwall to any strong force. To help prevent damage, leave Powerwall in its shipping packaging until it is ready to be installed.
-  **WARNING:** Do not insert foreign objects into any part of Powerwall.
-  **WARNING:** Do not expose Powerwall or its components to direct flame.
-  **WARNING:** Do not install Powerwall within 24 inches (610 mm) of heating vents or radiators. Powerwall can be installed in a mechanical room with HVAC equipment.
-  **WARNING:** If installing Powerwall indoors, a detection system for flammable gases must be installed at the site. Example: Smoke or heat detection devices.
-  **WARNING:** Ensure that concentrated water sources do not drain onto Powerwall or Backup Gateway, including downspouts, roofs without gutters, or drains.
-  **WARNING:** Do not immerse Powerwall or its components in water or other fluids.
-  **CAUTION:** Powerwall is not designed nor warranted for non-stationary applications.
-  **CAUTION:** Do not use solvents to clean Powerwall, or expose Powerwall to flammable or harsh chemicals or vapors.
-  **CAUTION:** Do not use fluids, parts, or accessories other than those specified in this manual, including use of non-genuine Tesla parts or accessories, or parts or accessories not purchased directly from Tesla or a Tesla-certified party.
-  **CAUTION:** Do not place Powerwall in a storage condition for more than one (1) month, or permit the electrical feed on the Powerwall to be severed for more than one (1) month, without placing Powerwall into a storage condition in accordance with Tesla's storage specifications.
-  **CAUTION:** Do not paint, coat, or wrap any part of Powerwall, including any internal or external components such as the exterior shell or casing. These may cause Powerwall to overheat, resulting in damage to the product.



Supported Configurations

At the time of publication, the only supported installation configurations are Powerwall 3 (up to (4) units) installed with Backup Gateway 2. When Powerwall 3 is installed with Backup Gateway 2, AC-coupled solar can be installed with the system.

All Site metering must be performed by Backup Gateway. Powerwall 3 performs its own Solar metering; if the system includes AC-coupled solar, it must be metered by Backup Gateway 2 Meter Y with Tesla CTs. Neurio meters are not supported at the time of publication.



SPECIFICATIONS

Powerwall 3 Specifications

System Technical Specifications

Model Number	1707000-xx-y		
Nominal Grid Voltage (Input & Output)	230 VAC		
Grid Type	Single phase		
Frequency	50 Hz		
Nominal Battery Energy¹	13.5 kWh		
Nominal Output Power (AC)	5 kW	10 kW	11.04 kW
Maximum Apparent Power	5,000 VA	10,000 VA	11,040 VA
Maximum Continuous Current	21.7 A	43.5 A	48 A
Overcurrent Protection Device	32 A	50 A	63 A
Maximum Continuous Charge Power	5 kW		
Output Power Factor Rating	0 - 1 (Grid Code configurable)		
Maximum Output Fault Current (1 s)	160 A		
Maximum Short-Circuit Current Rating	10 kA		
Maximum AC Current Inrush (0 s)	0 A P-P		
Load Start Capability (1 s)	185 locked rotor amps (LRA)		
Power Scalability	Up to 4 Powerwall 3 units supported ²		
Protection Class	Class I		
Overvoltage Category	III		
PV Inverter Topology	Non-Isolated		
BESS Inverter Topology	Isolated		
Surge Withstand Voltage on AC Ports	4 kV		
Surge Withstand Voltage on Communication Ports	2 kV		
Radiated RF Immunity	35 V/m		
Solar to Battery to Grid Round Trip Efficiency	89% ^{1,3}		
Solar to Grid Efficiency	97.5%		



SPECIFICATIONS

Supported Islanding Devices	Backup Gateway 2
Connectivity	Wi-Fi (2.4 and 5 GHz), Dual-port switched Ethernet, Cellular (LTE/4G ⁴)
Hardware Interface	Dry contact relay, Demand Response Enabling Device, RS-485 for meters
AC Metering	Revenue Grade (+/- 0.5%)
Protections	Integrated arc fault circuit interrupter (AFCI), Isolation Monitor Interrupter (IMI), integrated DC isolator
Customer Interface	Tesla Mobile App
Warranty	10 years

¹Values provided for 25°C, at beginning of life. 3.3 kW charge/discharge power.

²The maximum number of Powerwall 3 units per installation may vary by market.

³Typical solar shifting use case.

⁴Cellular connectivity subject to network service coverage and signal strength.

 **NOTE:** Powerwall 3 follows the Active islanding methodology by allowing frequency of the Powerwall 3 to be inherently unstable in the absence of a reference frequency (frequency instability).

 **NOTE:** The model numbers in this manual call out "-XX-Y" for the suffix of the equipment model number. The wild cards are defined as follows:

- "X" is a number and the one number in the model number representing a style code; form, fit, and function are not changed, and these numbers have no bearing on compliance.
- "Y" is a letter, and the one letter in the model number representing a pedigree; form, fit, and function are not changed, and this letter has no bearing on compliance.



SPECIFICATIONS

Solar Technical Specifications

Maximum Solar STC Input	20 kW
Withstand Voltage	600 V DC
PV DC Input Voltage Range	60 – 550 V DC
PV DC MPPT Voltage Range	60 – 480 V DC
MPPTs	3
Maximum Current per MPPT (I_{MP})	26 A
Maximum Short Circuit Current per MPPT (I_{SC})	30 A
PV Maximum Backfeed Current	0.2 A

Mechanical Specifications

Dimensions	1105 x 609 x 193 mm ⁵
Weight	130 kg
Mounting Options	Floor or wall mount

⁵These dimensions include the glass front cover being installed on Powerwall 3.



Environmental Specifications

Operating Temperature	-20°C to 50°C ⁶
Operating Humidity (RH)	Up to 100%, condensing
Storage Temperature	-20°C to 30°C, up to 95% RH, non-condensing, State of Energy (SOE): 25% initial
Maximum Elevation	3000 m
Environment	Indoor and outdoor rated
Enclosure Rating	IP55
Ingress Rating	IP67 (Battery & Power Electronics) IP55 (Wiring Compartment)
Pollution Rating	PD3
Operating Noise @ 1 m	<50 db(A) typical, <62 db(A) maximum

⁶Powerwall 3 is designed to operate in all climates from temperatures of -20°C to 50°C. Performance may be de-rated at operating temperatures above 40°C.



Compliance Information

Specification	Standard certified
Safety	IEC 62477-1: 2022 - Safety requirements for power electronic converter systems and equipment - Part 1: General
	IEC 62109-1:2010 - Safety of power converters for use in photovoltaic power systems - Part 1: General requirements
	IEC 62109-2: 2011 - Safety of power converters for use in photovoltaic power systems - Part 2: Particular requirements for inverters
	IEC 62933-5-2: 2020 - Electrical energy storage (EES) systems - Part 5-2: Safety requirements for grid-integrated EES systems - Electrochemical-based systems
	IEC 62619: 2022 - Secondary cells and batteries containing alkaline or other non-acid electrolytes - Safety requirements for secondary lithium cells and batteries, for use in industrial applications
	UL 1973: Batteries for Use in Stationary and Motive Auxiliary Power Applications
	UL9540A: Test Method for Evaluating Thermal Runaway Fire Propagation in Battery Energy Storage Systems
Grid Interoperability	AS 4777.2 Grid Connection of Energy Systems via inverter Part 2 Inverter Requirements
Energy Storage	Energy Storage Systems and Equipment [ANSI/CAN/UL 9540:2020 Ed.2]
EMC	IEC 61000-6-1:2016 - Electromagnetic compatibility (EMC) - Part 6-1: Generic standards - Immunity standard for residential, commercial and light-industrial environments
	EN IEC 61000-6-3: 2020 - Electromagnetic compatibility (EMC) - Part 6-3: Generic standards - Emission standard for equipment in residential environments



Backup Gateway 2 Specifications

Backup Gateway 2 Electrical Specifications

AC Voltage (Nominal)	230 V (Line-to-Neutral)
	400 V (Line-to-Line)
Feed-In Type	Single Phase, Three Phase
Grid Frequency	50 Hz
Maximum Overcurrent Protection Device	100 A (single-phase service)
	80 A (2- and 3-phase service)
Maximum Input Short Circuit Current	10 kA
Overvoltage Category	Category III
AC Meter	Revenue accurate (+/- 0.2 %)¹
Safety	IEC 61439-1, IEC 61439-3
¹Revenue accurate when using Gateway internal site meter.	



NOTE: Refer to circuit breaker datasheet for rated peak withstand current (Ipk) and associated duration.

Environmental Specifications

Operating Temperature²	-20°C to 50°C
Operating Humidity (RH)	Up to 100%, condensing
Maximum Altitude	3000 m
Ingress Rating	IP55
Environmental Category	Indoor and outdoor rated
Wet Location Rating	Yes
Pollution Degree	PD2
² Performance may be de-rated in extreme ambient temperatures	

Mechanical Specifications

Height	584 mm
Width	380 mm
Depth	127 mm
Weight	11.4 kg



REGISTERING POWERWALL 3

Tesla Powerwall 3 comes with a warranty whose term depends on the connection of Powerwall 3 to the internet. To secure the full 10-year warranty for Powerwall 3, it must be reliably connected to the internet to allow remote firmware upgrades from Tesla. If an internet connection is not established or is interrupted for an extended period, and Tesla is unable to contact the owner, the warranty may be limited to 4 years. To ensure that the owner can receive the full 10-year warranty, be sure to complete the device setup process so that registration information is sent to Tesla.

For more information, refer to the Powerwall 3 Warranty for your region at www.tesla.com.



POWERWALL 3 OVERVIEW

Powerwall 3 is a fully integrated solar and battery system that stores energy from solar production. It converts energy from solar panels, and its rechargeable battery pack provides energy storage. Powerwall 3 can operate as a grid-supported or multiple mode inverter; this means having grid-interactive functionality when grid voltage is present, and operating in stand-alone mode when the grid is de-energized or disconnected.

Figure 1. Expanded View of Powerwall 3

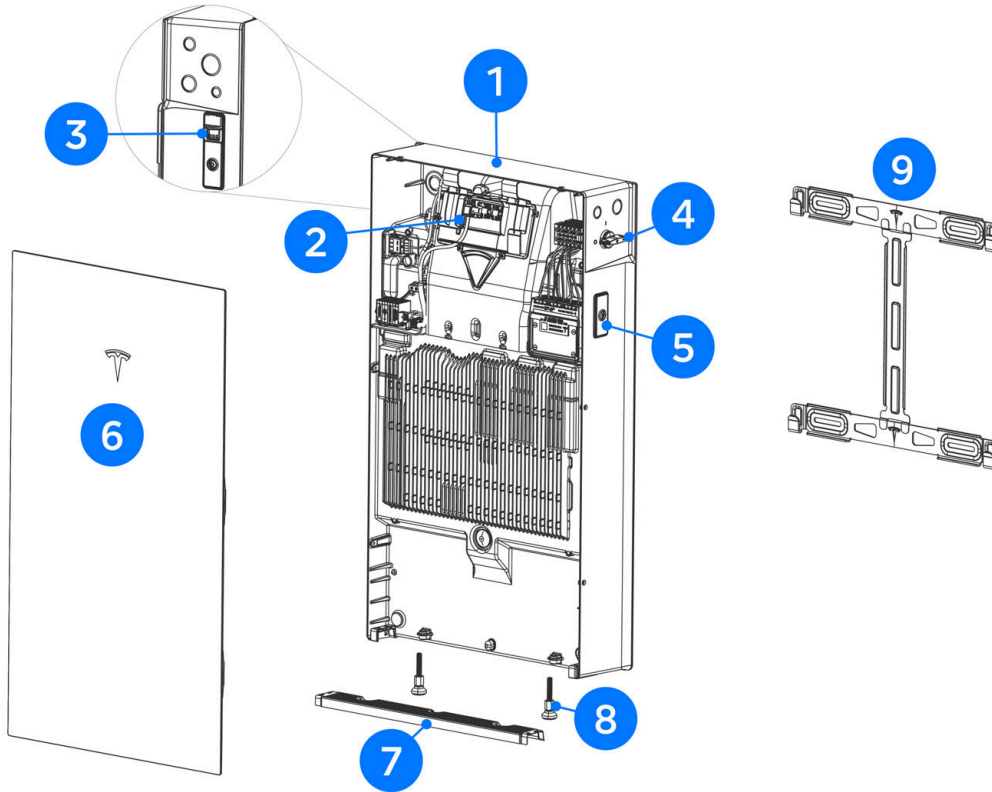

1	Powerwall 3
2	Tesla Asset Controller (TACO)
3	On / Off switch
4	Integrated DC Isolator
5	Expansion port cover
6	Glass front cover
7	Air intake screen
8	Leveling feet
9	Wall mounting bracket

 **NOTE:** Do not remove the expansion port covers. These are protective covers and Powerwall 3 will not operate when they are removed.



POWERWALL 3 SYSTEM DESIGN GUIDANCE

Design Considerations

Supported Configurations

- Up to (4) Powerwall 3 units can be installed with Backup Gateway 2, with or without AC-coupled solar
- Powerwall 3 is not yet compatible with the following:
 - Neurio remote energy meters (all metering must be performed by Backup Gateway 2; see [Metering Considerations on page 19](#) for more information)
 - Other batteries (Powerwall 2 or third party batteries)
 - Stacked units (Powerwall 3 must be mounted in a side-by-side configuration)

System Tie-in

- Only Tesla devices are compatible with Powerwall; no third-party equipment in lieu of Backup Gateway 2
- Backup systems must be one of the following:
 - 230 V single phase service
 - 100 A or smaller service, or (in absence of a service rating) maximum 100 A of loads downstream of Backup Gateway 2
 - 230 / 400 V three phase service
 - 80 A or smaller service, or (in absence of a service rating) maximum 80 A of loads downstream of Backup Gateway 2
 - Follow all local requirements for balancing the system equally across the available phases



NOTE: Regardless of the number of Powerwalls installed, only one phase (L1, L2, or L3) will provide backup during a grid outage.

- A breaker is always utilized for Powerwall 3 tie in; see [Install Powerwall and Generation Breakers in the Backup Gateway on page 52](#) for breaker size options based on desired power output
- Powerwall 3 must always be connected to the Home terminals downstream of the Backup Gateway 2
- Recommend that total Powerwall supply is able to power the single largest automatic load in the backup circuit (see [Backup Loads Supported per Powerwall Quantity on page 15](#))
- Any/all backup load centers are adequately protected with an overcurrent protection device
- All three phase loads or solar must be excluded from the backup phase on the Home terminals
- All single phase loads in the backup circuit must be sized appropriately for the configured power output of the Powerwall (see [Install Powerwall and Generation Breakers in the Backup Gateway on page 52](#) for power output options)
- Site and solar monitoring must be installed to capture overall power flow to/from the site, as well as all solar production
- Powerwall and Backup Gateway 2 are rated for 10 kA of fault current.



POWERWALL 3 SYSTEM DESIGN GUIDANCE

Powerwall 3 Solar

Powerwall 3 has an integrated inverter and 3 MPPTs, with a maximum solar input of 20 kW DC.

 **NOTE:** See [AC-Coupled Solar System Sizing on page 18](#) for information about sizing AC-coupled solar with Powerwall 3.

System Sizing

The following resources explain how to size the Powerwall 3 system to meet customer expectations, as well as how to determine which loads can be included in the backup circuit and what to do with loads that cannot be included.

Backup Loads Supported per Powerwall Quantity

- The largest load in the backup circuit is limited by the quantity of Powerwalls; the largest load/breaker size each Powerwall 3 can support is determined by the selected Powerwall 3 breaker size and configured power output (see [Install Powerwall and Generation Breakers in the Backup Gateway on page 52](#))
- See [Appendix F: Installations with Multiple Powerwall 3 Units on page 105](#) for requirements for installing multiple Powerwall units.

AC Units and Large Motor Loads

- Inrush current (largest instantaneous current draw when a motor starts) is limited to 185 A locked rotor amps (LRA) per Powerwall 3.
- For air conditioner units, use locked rotor amps on equipment label as inrush current.
- Design Options if motor locked rotor amps is greater than the number of Powerwall 3 units multiplied by 185A:
 - Increase number of Powerwalls
 - Relocate AC unit/motor load out of backup circuit
- Example:
 - Motor Load unit with 200 A locked rotor amps
 - Required Powerwall(s): (2) Powerwall 3 units required, so that 200 A < 370 A

 **NOTE:** Double-check that the AC breaker follows the Powerwall breaker sizing rules.

EV Charging

Type of Electric Vehicle Charging	Compatibility
Tesla vehicle charging (Wall Connector or Tesla Mobile Connector)	1 Powerwall*
Third-Party Level 1 EV charging	1 Powerwall*
Third-Party Level 2 EV charging	1-2 Powerwalls*

*Ensure the configured power output is great enough to support the charger(s) when off-grid; for instance, if Powerwall 3 has a configured power output of 5 kW, (2) Powerwall 3 units would be required to back up a Tesla vehicle charger.

Per the [Vehicle Charging During Outage feature](#), the system will adjust the charging power during an outage to ensure Powerwall can continue to support the home without overloading Powerwall, and will only charge the vehicle when the percentage of charge is higher than the limit set by the customer.



Powerwall 3 DC System Sizing

- Powerwall 3 can be configured as up to a 11.04 kW AC rated inverter that can support up to a maximum DC system size of 20 kW.
 - 20 kW DC is the absolute maximum solar system size that Powerwall 3 can support.
 - Powerwall 3 has a boosting feature that can send 5 kW continuously from solar to the battery at the same time that 11.04 kW of solar is inverted to AC power, leading to a potential total DC power of 16.04 kW. This helps alleviate clipping concerns and enables sizing the DC system larger, but only if the battery is being used in a way that it will have available charge power during the peak solar production hours of the day.
 - If Powerwall 3 is power / current limited, a larger DC solar system size may experience curtailment. Size the DC solar system appropriately based on the configured power / current output.
 - Where clipping may occur, the amount of clipping depends on the specific scenario.
- Each Powerwall 3 has (3) MPPTs available for Solar.



NOTE: If there are more than three PV strings, strings can be combined upstream of Powerwall 3 so long as the voltage and current ratings of the system do not exceed the capabilities of Powerwall 3.

- When calculating the minimum and maximum number of modules per string, use the [Tesla Solar Stringing Tool](#) on Partner Portal. For instructions on how to use the tool, see the [User Guide](#). Or, you can use the following variables and equation:
 - A = VOC at standard test conditions (STC) for the modules
 - B = Voltage temperature coefficient
 - C = Number of modules in string
 - $A * B * C = X$
 - $60 \leq X \leq 550V$
- Total DC circuit distance, from + MPPT terminal to - MPPT terminal (including module wire leads, jumper wires and all wiring within the array boundary for any individual string), shall not exceed 160 m for single strings or paralleled strings
 - Total DC circuit distance refers to the entire round trip wire distance, from inverter to the roof, then back to the inverter
 - Ensure paralleled strings are the same distance, or as close to the same distance as possible
- Powerwall 3 is a string inverter. Individual strings should not be extended over mounting planes with different pitches and/or azimuths to provide peak performance of the system. Series strings must have modules on the same pitch & azimuth, and strings of equal distance can be combined in parallel.
 - Note that a situation where all 20 kW are simultaneously producing at peak may result in solar clipping. Tesla recommends, but does not require, diversifying azimuths when the array is significantly oversized. The (3) MPPTs are particularly suited for sites where the strings may not be on the same azimuth and are therefore not producing at peak simultaneously.
- If installing multiple Powerwall 3 units, it is recommended but not required to distribute the DC PV system across all Powerwall 3 units so that each Powerwall 3 receives the benefits of DC coupling solar

Available Third-Party Solar Design Tools

Powerwall 3 has been added to the following solar design tool databases:

- Open Solar



POWERWALL 3 SYSTEM DESIGN GUIDANCE

- Pylon



AC-Coupled Solar System Sizing

DC-coupled solar (connected directly to Powerwall 3) is strongly preferred over AC-coupled solar for the following reasons:

- Less equipment required for DC-coupled solar, resulting in reduced system cost
- Increased efficiency for DC-coupled solar
- Low energy management during a grid outage

In some scenarios, it is difficult or not feasible to avoid systems with AC-coupled solar. Most commonly, this occurs when Powerwall 3 is installed on a system with existing AC-coupled solar. As shown below, solar can be installed alongside Powerwall 3 solar, or with Powerwall 3 as storage only.

Figure 2. Powerwall 3 with AC and DC Coupled Solar

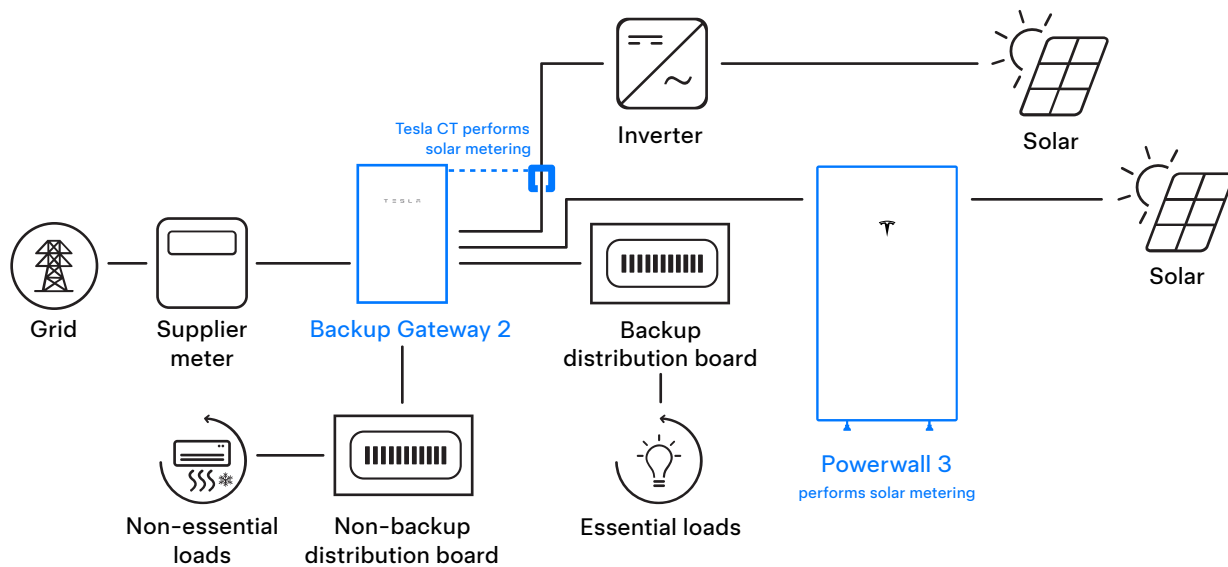
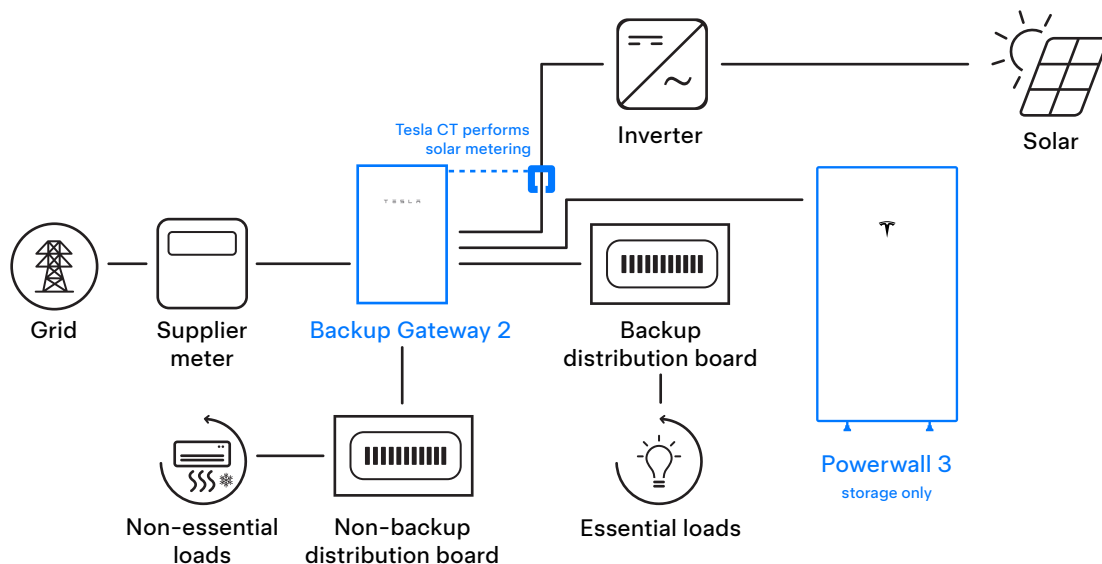

Figure 3. Powerwall 3 with AC Coupled Solar (Storage Only)





For systems with AC-coupled solar only, a maximum of 5 kW AC per Powerwall is allowed in the backup circuit (the smaller of AC inverter rating or DC system size¹).



POWERWALL 3 SYSTEM DESIGN GUIDANCE

¹The 5 kW PV to Powerwall ratio was put in place to protect the Powerwall system from excessive PV power during a grid outage. 5 kW is used because it is a common solar inverter size, allowing more PV systems to be fully backed up without needing to be split apart, and inverters don't always produce their maximum power. This ratio does not prevent all issues; Powerwall's maximum charge rate is 5 kW under ideal conditions (notably operating temperature). If there is more than 5 kW of excess PV per Powerwall, the system will frequency shift to try to reduce PV power, and may have to shut PV production down completely.

 **NOTE:** The AC-coupled PV to Powerwall ratio and the maximum DC solar system sizing are independent of each other. See [Powerwall 3 DC System Sizing on page 16](#) for information about sizing the Powerwall 3 DC system.

 **CAUTION:** Exceeding the PV to Powerwall ratio may result in high fault current during a grid outage, which creates a serious risk of damage to Powerwall and/or the customer's home loads. If a Powerwall is damaged by high fault current due to excess PV during an outage, it will be out of warranty.

Options to avoid exceeding the ratio:

1. Increase number of Powerwalls on site
2. Utilize Powerwall 3 for all PV on site to avoid PV to Powerwall ratio
3. Split PV Inverter Point of Interconnection, In / Out of backup (confirm with local electrical regulator that this practice is accepted)
4. Downsize PV to meet ratio
5. Shed part of the PV system using grid dependent relays/contactors

 **NOTE:** The 5 kW PV to Powerwall ratio can be applied to any Powerwall unit in the system, including Powerwall 3. For example, a 5 kW third party solar inverter can be backed up with a single Powerwall 3, as the ratio rule does not apply to the solar inverter portion of the Powerwall 3.

Undersized Powerwall 3 Systems

If a customer acknowledges that they are willing to back up a large load that violates Tesla's guidance on what can be included in backup, design can proceed as long as the customer provides acknowledgment that they accept an undersized system.

 **NOTE:** Undersized systems cannot be designed if the electrical regulator does not allow oversized loads in the backup circuit.

Metering Considerations

 **NOTE:** Powerwall 3 is not compatible with any remote energy meters, including Neurio remote energy meters.

Site Metering

Backup Gateway 2 has an internal meter (Internal Primary Meter X) for monitoring Site. Please ensure that the Powerwall 3 system can meter the entire site using the meters available, including Meter Y for Non-Backup loads that are upstream of Backup Gateway 2. This means that currently:

- Powerwall 3 can only be used on services up to 100 A.
- Powerwall 3 systems cannot meter more than 100 A of non-backup loads.



POWERWALL 3 SYSTEM DESIGN GUIDANCE



NOTE: Backup Gateway 2 can only meter non-backup loads OR AC-coupled solar, not both.

Solar Metering

- **Powerwall 3 Solar:** Powerwall 3 performs its own solar metering. No additional Solar metering needs to be installed or configured for Powerwall 3.
 - Powerwall 3 can also be used without any solar on the site.
- **AC-coupled Solar:** All AC-coupled solar must be monitored; at the time of this document's publication, the only option for metering Solar is using Tesla CTs connected to Backup Gateway 2.



CAUTION: If AC-coupled solar is not metered correctly, Powerwall will not frequency shift to control solar during a grid outage, resulting in a serious risk of damage to the customer's home loads and/or Powerwall.





SITE REQUIREMENTS AND PRE-INSTALLATION GUIDANCE

Ensure Installation Meets All Local Codes and Requirements

Powerwall 3 comes with a Backup Gateway 2 to enable integration with the electrical grid. Powerwall 3 communicates with Backup Gateway 2 by means of a wired connection; wiring and conduit (where required) must be provided by the installer and installed to comply with local codes.

 **WARNING:** When Powerwall 3 is installed in a dwelling unit, fire detection and protection equipment should be installed in accordance with local building and fire codes.

 **WARNING:** Powerwall is not intended for installation in habitable spaces and living spaces in dwelling units.

 **WARNING:** Install Powerwall in a location that prevents damage from flooding.

 **CAUTION:** When installing Powerwall in a garage or near vehicles, keep it out of the driving path. If possible, install Powerwall on a side wall and/or above the height of vehicle bumpers.

 **CAUTION:** Ensure that no water sources are above or near Powerwall, including downspouts, sprinklers, or faucets.

 **CAUTION:** Ensure that snow does not accumulate around Powerwall.

 **CAUTION:** Before installing, disconnecting, and/or adjusting current transformers for metering, ensure the circuits being measured are not energized and the system is completely powered down. Failure to de-energize the system may compromise operator and equipment safety.

 **CAUTION:** The Backup Gateway may not be recessed into a wall or cavity.

 **NOTE:** All installations must conform to the laws, regulations, codes, and standards applicable in the jurisdiction of installation.



PREPARING FOR INSTALLATION

In the Powerwall 3 Box

- Glass front cover
- Powerwall 3
- Wall mounting bracket
- Air intake screen

In the Powerwall 3 Accessory Bag

Powerwall 3 Accessory Bag: Tesla P/N 1857363-30-x

- (8) M6x17 fasteners for mounting the Powerwall 3 front cover (Tesla P/N 1847553-00-A)



NOTE: Early revisions of the front cover fasteners are single use; see [STEP 12: Install Powerwall 3 Front Cover on page 76](#) for instructions to remove the black gasket from these fasteners to reuse them. Only (6) fasteners are required, with (2) extra fasteners included in the accessory bag.

- (7) PV wiring forked terminals
- (1) small square clamp-on ferrite core with cable tie for the Tesla Asset Controller (TACO) low voltage harness
- (2) medium clamp-on ferrite cores with cable ties for the AC conductors
- (2) medium *marked* (with pink sticker) clamp-on ferrite cores with cable ties for the AC conductors
- (1) small clamp-on ferrite core with cable tie for the Protective Earth



PREPARING FOR INSTALLATION

In the Backup Gateway 2 Box

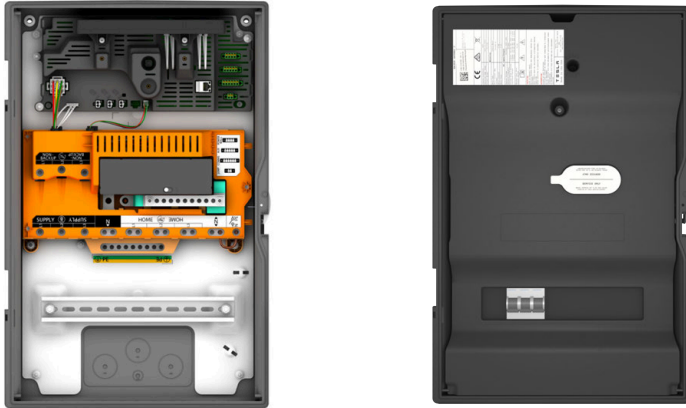

In the Backup Gateway 2 Accessory Bag

- (1) Adhesive circuit label
- (1) CT extension cable harness (3 m)
- (3) M6 rubber bonded stainless steel washers
- (5) 8 mm backplate nuts
- (1) M25 communication gland and insert
- (1) Solar CT (100 A, split-core)
- (1) Powerwall 2 Owner's Manual (can be recycled when Backup Gateway 2 is installed with Powerwall 3; the Powerwall 3 owner's manual is available to the customer via their Tesla mobile app)



PREPARING FOR INSTALLATION

Powerwall 3 Service Parts, Orderable Parts, and Accessories

 **NOTE:** Some of the parts and kits listed below may not be orderable by Channel Partners; for a list of parts and kits that can be ordered by Channel Partners, please see the *Powerwall Pricing Guide* on Partner Portal.

 **NOTE:** In the part numbers listed below, -xx-y are placeholder values.

Tesla Part Number	Name	Description
1856187-xx-y	Powerwall Dolly	Custom-designed dolly for lifting and transporting Powerwall
1738120-xx-y	Powerwall 3 Mounting Bracket	(1) Additional Powerwall Wall Mounting Bracket (1 bracket is included with every Powerwall) Only needed if original mounting bracket is lost or damaged
1857363-30-A	Powerwall 3 Accessory Bag	Additional Powerwall 3 accessory bag (1 accessory bag is included with every Powerwall)
1763418-01-y	Powerwall 3 Front Cover Assembly	Service replacement glass front cover and (8) fasteners for Powerwall 3
1899124-xx-y	Powerwall 3 On/Off Switch Cover	Service replacement Powerwall 3 On/Off switch cover
1893723-xx-y	Powerwall 3 Expansion Port Cover	Service replacement Powerwall 3 expansion port cover
1808482-xx-y	Powerwall 3 Foot	Service replacement Powerwall 3 leveling foot (quantity 1)
1775504-xx-y	Powerwall 3 Air Intake Screen	Service replacement Powerwall 3 air intake screen
1857363-02-y	Front Cover Fasteners for Powerwall 3	Additional (8) M6x17 fasteners for securing the Powerwall 3 glass front cover



PREPARING FOR INSTALLATION

Required Tools

General Tools

- Personal protective equipment (safety glasses, gloves, protective footwear)
- Installation tools (level, stud sensor, tape measure, pencil, painter's tape, flashlight)
- Smart phone with Tesla One app for performing device setup and documenting the installation
- Drill and drill bit for drilling pilot holes in mounting surface
- Torque wrench / screwdriver with T20 Torx bit
- Wire strippers/cutters for 0.2 mm² to 120 mm² wires
- Up to 3 mm electronics tip slotted screwdriver for AC and communication wiring spring terminals

Powerwall 3 Installation Tools

- Powerwall dolly (preferred, Tesla P/N 1856187-xx-y) OR lift equipment capable of lifting and supporting 287 lb (130 kg)
- ¾-inch hex nut or 19 mm drill socket (if using Powerwall dolly)
- Ratcheting strap to secure Powerwall 3 to lift equipment (if not using Powerwall dolly)
- Ratcheting die crimping tool for crimping forked terminals onto PV wiring; Tesla recommends any of the following or equivalent:
 - TE Connectivity P/N 58433-3
 - TE Connectivity P/N 59824-1
- Phillips #2 (reduced diameter PR2 or PH2R) screwdriver with minimum 25 mm shaft length and maximum 5.4 mm tool diameter for the PV wiring terminals

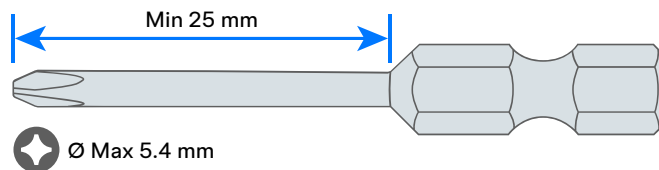

- Multimeter and Loop Impedance Tester

WARNING: Powerwall 3 is heavy. Wear appropriate personal protective equipment (such as gloves and protective footwear) when handling the unit. Only a sufficient number of trained movers should lift Powerwall 3. Use of lift equipment is recommended.

Backup Gateway Installation Tools

- Small bit for drilling pilot holes in Backup Gateway mounting surface
- Hole saws for drilling cable access holes in Backup Gateway (M12, M20, M25, M32, M40, M50)
- Torque wrench with 3 mm Allen bit (for Backup Gateway power connections)



PREPARING FOR INSTALLATION

Required Supplies

- Mounting bracket hardware (see [Appendix A: Powerwall 3 Anchoring Details on page 82](#))
- Backup Gateway 2 mounting hardware
- External Load Break switch that may be employed with the Powerwall; must conform to AS/NZS 4777.1 and AS 3000
- Minimum 300 V rated, UV resistant, 70°C rated, copper (Cu) wire, 6 mm² to 25 mm², for AC wiring



NOTE: PV and AC wiring conductors must be made of solid wire, stranded wire or fine stranded wire. Forked terminals are required for fine stranded wire.

- Minimum 600 V rated, UV resistant, 75°C rated, copper (Cu) wire, 6 mm² to 10 mm², for PV wiring
- Insulated forked terminals for PV wiring; Tesla recommends the following or equivalent:
 - TE Connectivity P/N 165015 (4 - 6 mm² wire size)



NOTE: Follow the manufacturer's guideline to properly crimp the forked terminals.

- Minimum 300 V rated (or equivalent) 4-conductor shielded copper (Cu) communication cable with at least one twisted pair



NOTE: This cable is used for communication connection between Powerwall and the Backup Gateway; the twisted pair is required for the CAN communication conductors (see [STEP 6: Connect Powerwall 3 to Backup Gateway on page 55](#) for details).

- RJ45 connectors for Ethernet wiring
- Minimum IP65 cable glands or conduit connectors of the following sizes:
 - M20
 - M25
 - M32
 - M40
- Breaker for the Powerwall 3 circuit. Select the appropriate breaker size depending on the desired power / current output.

Power / Current Output (AC)	Breaker (Overcurrent Protection)
5 kW / 21.74 A	32 A
10 kW / 43.48 A	63 A
11.04 kW / 48 A	63 A



STEP 1: PLAN THE INSTALLATION SITE

Choose a Location that Meets Powerwall 3 Clearance Requirements

Powerwall 3 requires adequate clearance for installation, cabling, and airflow. The spacing on either side of units and between units is required to ensure there is sufficient clearance for venting and thermal management features. Do not install anything inside the required clearance above Powerwall 3, or anything that might fall and damage the unit. Do not mount Powerwall 3 horizontally or upside down.

Figure 4. Powerwall 3 Air Intake and Exhaust Vents

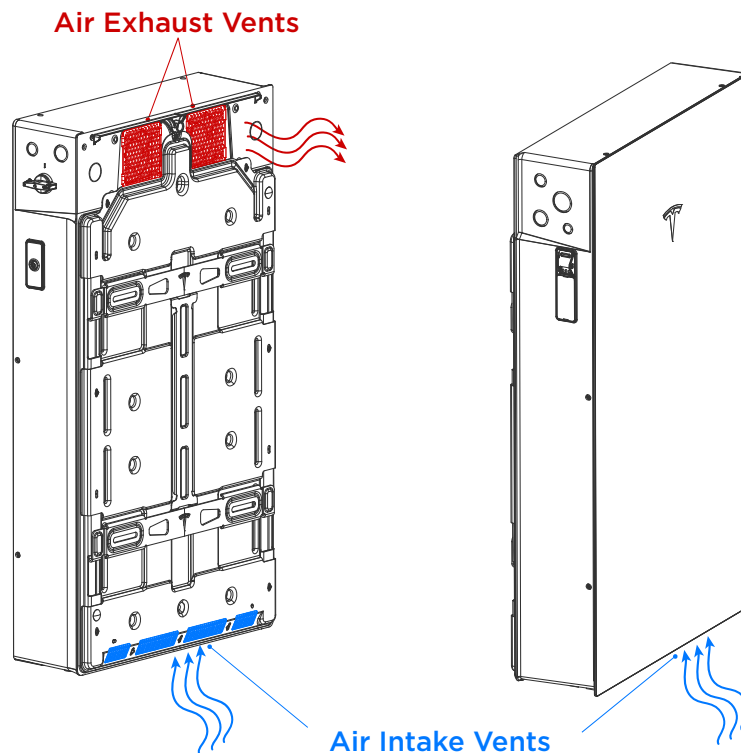

CAUTION: In addition to meeting all clearance requirements, ensure Powerwall 3 is installed on a flat surface that is clear of obstructions or protrusions that could damage Powerwall or inhibit airflow. The air vents on the rear and lower front of the unit must remain free from obstructions and accumulation of debris (like foliage or dust).



STEP 1: PLAN THE INSTALLATION SITE

Figure 5. Powerwall 3 Minimum Mounting Clearances

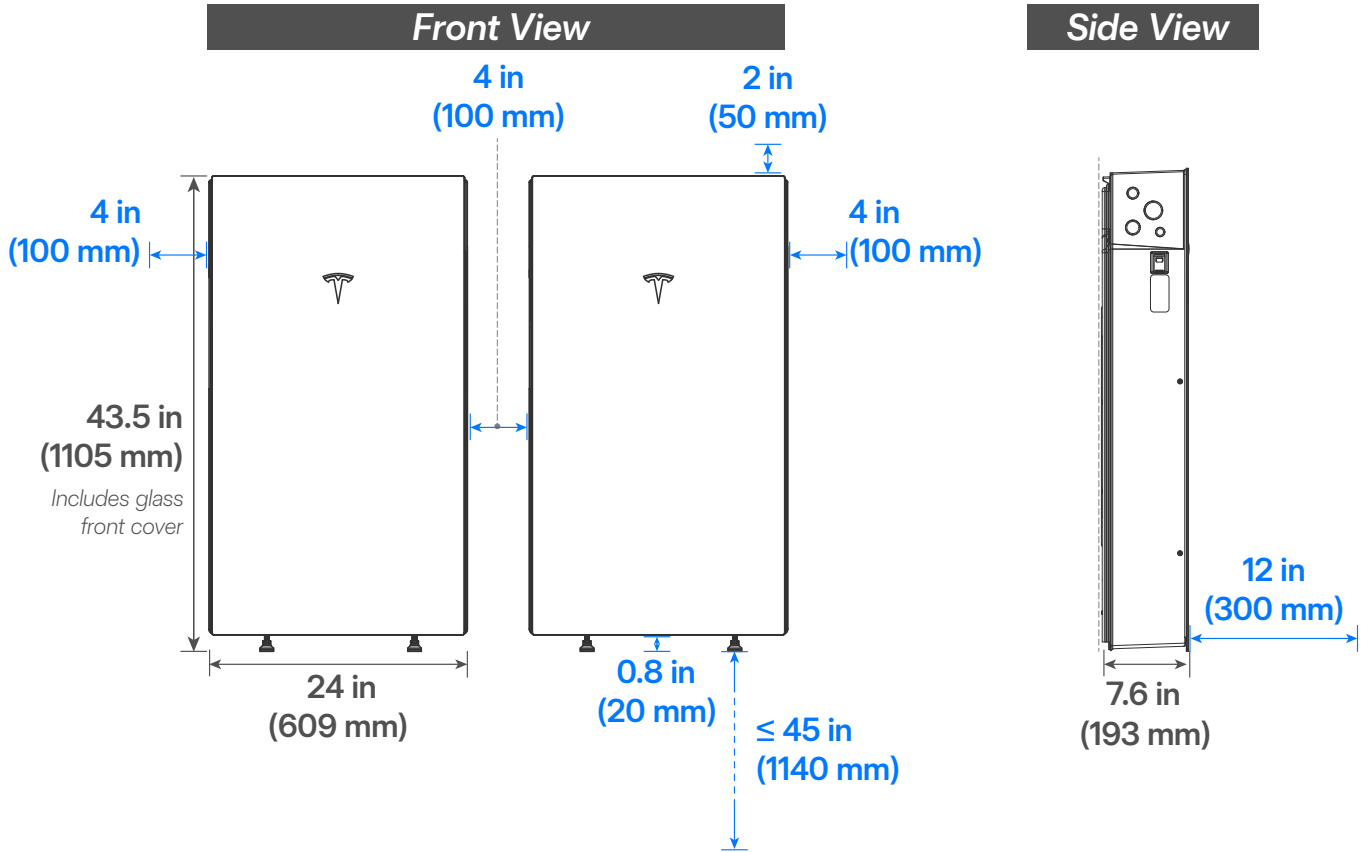

Minimum clearance from left side	100 mm
Minimum clearance from right side	100 mm
Minimum clearance above Powerwall	50 mm
Minimum clearance below Powerwall	20 mm
Minimum clearance between side-by-side Powerwalls	100 mm*
Minimum clearance in front of Powerwall	300 mm**
Maximum height above ground	1140 mm to bottom of unit feet
Maximum slope	+/- 2° side-to-side

*Tesla recommends a minimum of 150 mm between side-by-side units to allow for adequate space for wiring and On/Off switch access.

**This minimum clearance must be maintained at all times, as it ensures adequate airflow for Powerwall 3. Please note that more space may be required depending on local code and/or site conditions.

NOTE: Powerwall 3 has a fan that produces a gentle hum during operation, comparable to a typical refrigerator. The noise level depends on the ambient temperature and the power level of operation. Consider this noise level when choosing where to install Powerwall 3.



STEP 1: PLAN THE INSTALLATION SITE

Plan Powerwall 3 Mounting Configuration

Choose a Wall Capable of Supporting Powerwall 3

Choose a wall capable of supporting the full weight of Powerwall 3. Walls with the following characteristics are acceptable:

- Wood structural members at regular intervals
- Solid concrete or masonry

Other wall types are also acceptable depending on mounting configuration; see [Anchoring Details for Ground- or Wall-mounting Powerwall 3 with Wall Bracket on Existing Approved Foundation on page 82](#) for all acceptable wall types when mounting Powerwall 3 on the mounting bracket.

If ground-mounting Powerwall, choose a level surface adjacent to a wall space that meets the above requirements. Ensure the bearing surface is structurally sound and flat, and supports both Powerwall feet.

Plan Cable Length Between Components

Follow the table below for maximum distances between system components. Wire gauge must meet local codes and in some circumstances wire gauge requirements change based on distance. Refer to [Appendix B on page 85](#) for wire gauge requirements.

	Maximum Cable Length
CAN communication wiring between Backup Gateway 2 and Powerwall(s)*	45 m for 1.5 mm ² wire
	35 m for 1 mm ² wire
Wired Ethernet connection (minimum Cat5)	100 m
Total PV circuit distance*	160 m

*Ensure that total DC circuit distance, from + MPPT terminal to - MPPT terminal (including module wire leads, jumper wires and all wiring within the array boundary for any individual string), does not exceed 160 m for single strings

- Total DC circuit distance refers to the entire round trip wire distance, from Powerwall 3 to the roof, then back to Powerwall 3



CAUTION: Failure to follow minimum cable size and length requirements may result in intermittent or unreliable operation of the Powerwall system. In systems that do not meet these minimum requirements, performance issues may arise even after successful commissioning.

Maximum Tesla CT Extension

Tesla 100 A CTs (Remote Metering)	Maximum Extension Length
Using Tesla 100 A CT Extension 3 m (Tesla P/N 1467274-00-x)	Up to 3.8 m
Using 0.5 mm ² or larger twisted pair conductors	Up to 100 m



NOTE: Tesla CTs are only available for installations with Backup Gateway 2.



STEP 1: PLAN THE INSTALLATION SITE

Choose Powerwall Cable Entry

Determine whether cables will be routed into Powerwall from either side or the back of the unit. A conduit fitting or cable gland must be used to seal the entry into the wiring compartment.

CAUTION: The Powerwall 3 knockouts are **not** expandable. Do not drill into the Powerwall 3 enclosure or change any metal surface for any reason.

Figure 6. Powerwall 3 Knockout Locations

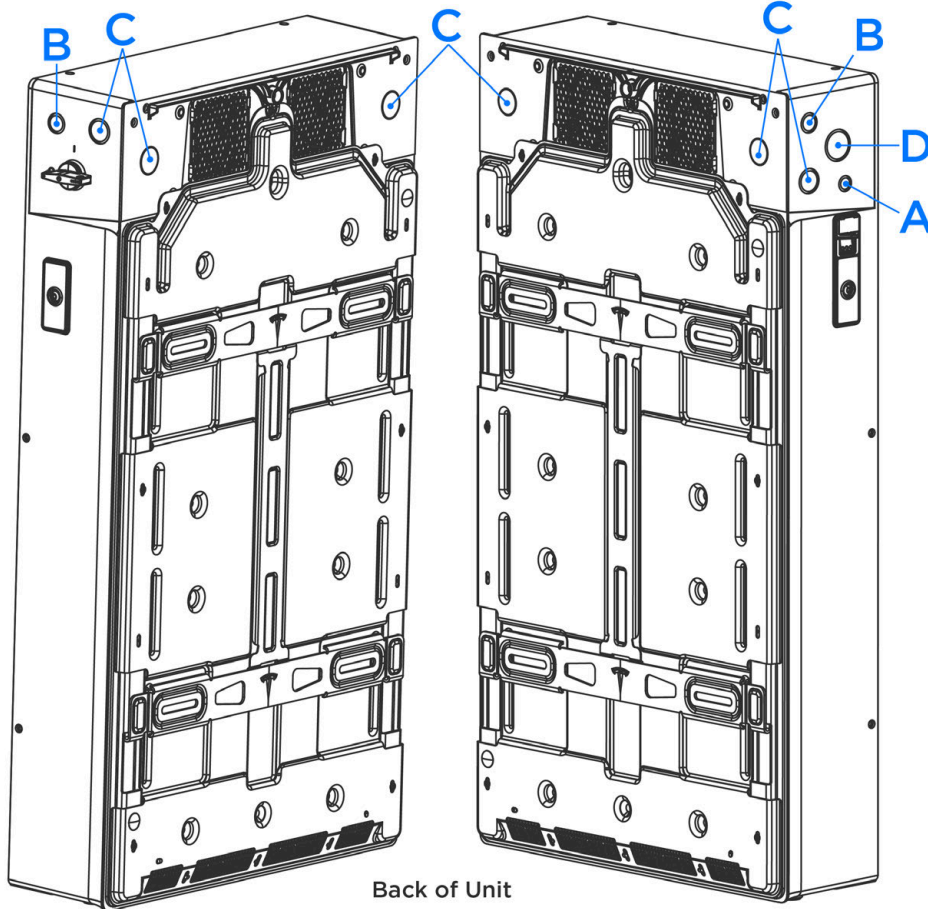



Table 1. Enclosure Knockout Sizes

Knockout	Conduit Size
A	M20
B	M25
C	M32
D	M40



STEP 1: PLAN THE INSTALLATION SITE

To open a knockout, position the tip of a slotted screwdriver on the inner perimeter of the knockout (on the outside of the enclosure). Hammer the screwdriver to punch out the metal knockout; one well-placed strike is generally sufficient to dislodge the knockout.

 **NOTE:** Placing the screwdriver on the inner perimeter of the knockout rather than the middle allows for the knockout to be opened with significantly less force.

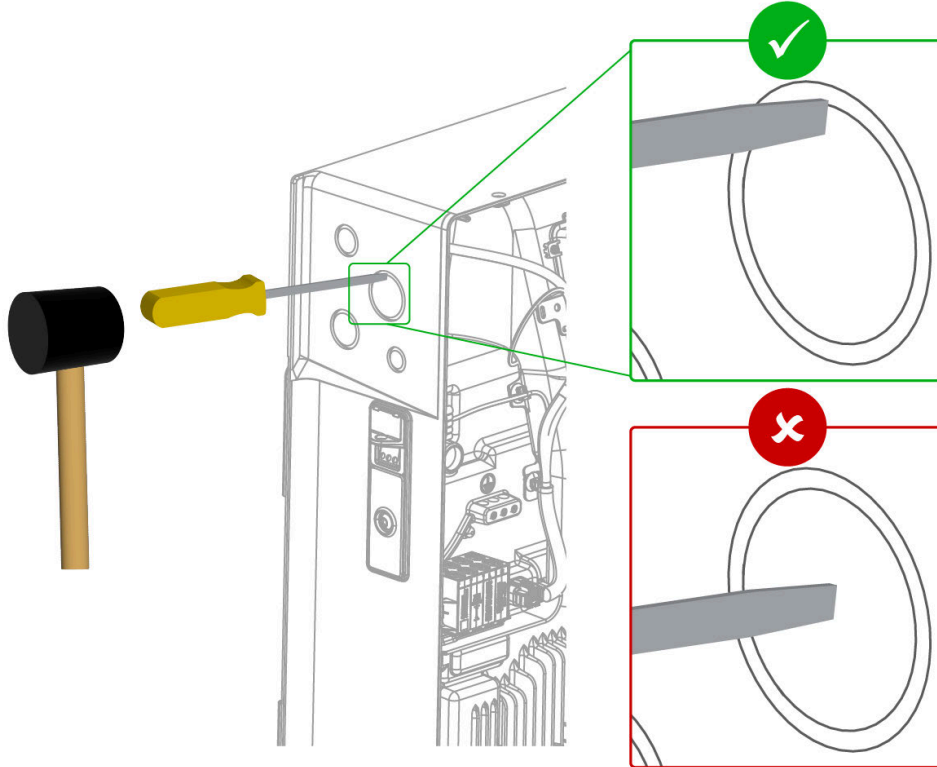

 **NOTE:** The following diagram provides measurements for positioning rear conduit entry holes relative to the Powerwall 3 bracket (the measurements are the same for both knockouts).

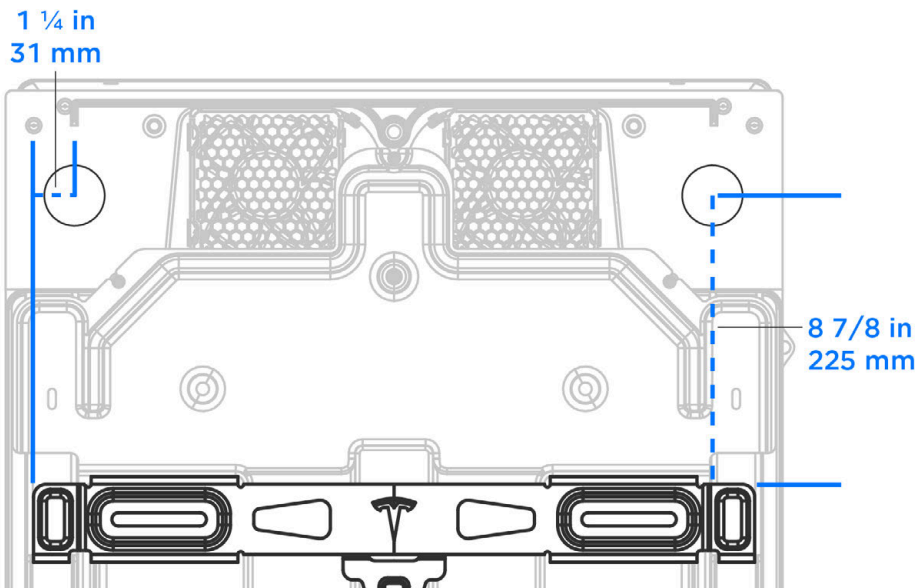



STEP 1: PLAN THE INSTALLATION SITE

Plan Amount and Size of Conduit or Raceway

Calculate the amount and size of conduit or raceway needed for the installation, based on fill limits and local code requirements. An adapter may be required between the entry into the Powerwall wiring compartment and the conduit.



STEP 2: REMOVE POWERWALL 3 FROM PACKAGING AND TRANSPORT USING THE POWERWALL DOLLY

WARNING: Do not move Powerwall 3 in its packaging while the packaging is standing upright. In this position, the Powerwall 3 unit can shift within the packaging, which may result in Powerwall 3 falling over.

1. Open the Powerwall packaging:
 - a. Carefully remove the box containing the glass Powerwall front cover and set it aside on an even surface.

CAUTION: Handle the glass front cover carefully. Avoid setting the cover on hard, uneven surfaces which could break the glass.

- b. Remove the accessory bag and set it aside.

NOTE: Please return the Powerwall 3 packaging to the warehouse that originally shipped the unit(s).

2. To lift Powerwall 3 using the Powerwall dolly, loosen the (2X) fasteners holding each lift handle in place, then detach the handles.

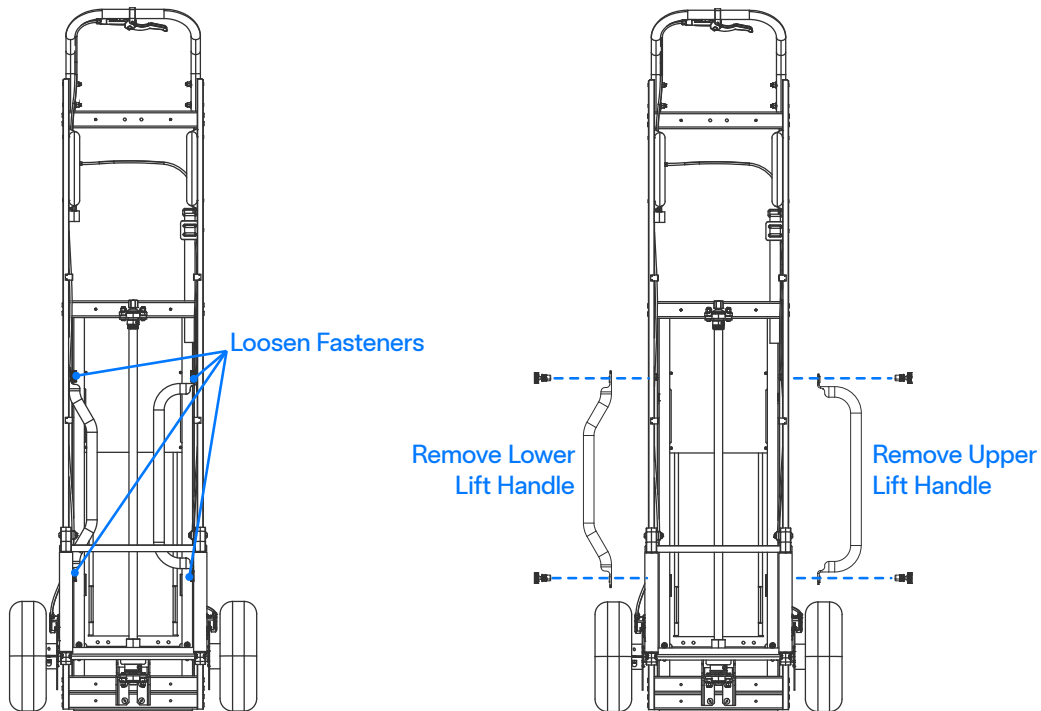



STEP 2: REMOVE POWERWALL 3 FROM PACKAGING AND TRANSPORT USING THE POWERWALL DOLLY



CAUTION: The Powerwall dolly is the recommended tool for transporting Powerwall 3. If using another dolly, ensure Powerwall 3 is facing toward the dolly and the front of the unit is protected by a piece of cardboard (for instance the cardboard box the bracket ships in) or a similar material. Use a strap to secure Powerwall to the dolly.

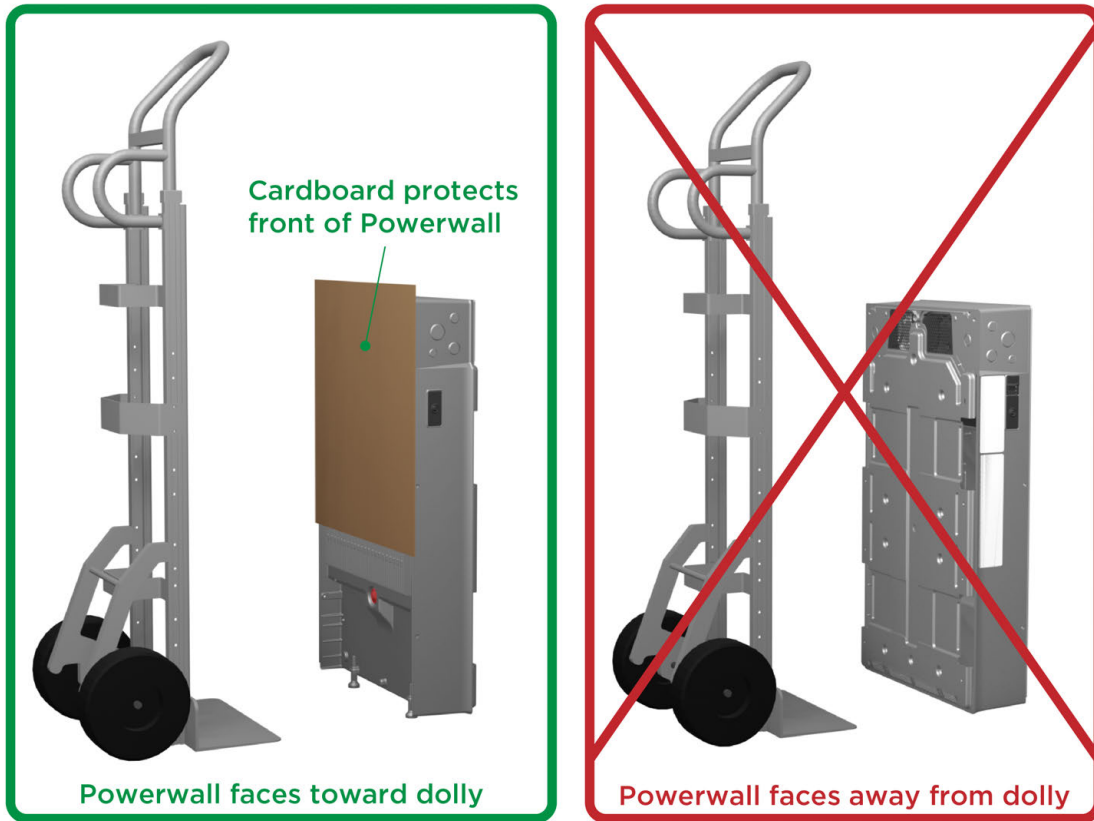

3. With Powerwall 3 still in the packaging, place the two lift handles on the Powerwall and tighten the (2X) fasteners on each handle to hold them in place. Note that upper handle is the larger, more rounded handle, and the lower handle is the smaller, more angular handle, and they attach to existing threaded mounting points. Perform a pull test to confirm the handles are secure before proceeding.



WARNING: Do not use the handles to manually lift Powerwall 3. These handles are designed to interface with the dolly; they are not designed to be load bearing, and attempting to lift Powerwall 3 with them could result in dropping and damaging the unit.



STEP 2: REMOVE POWERWALL 3 FROM PACKAGING AND TRANSPORT USING THE POWERWALL DOLLY

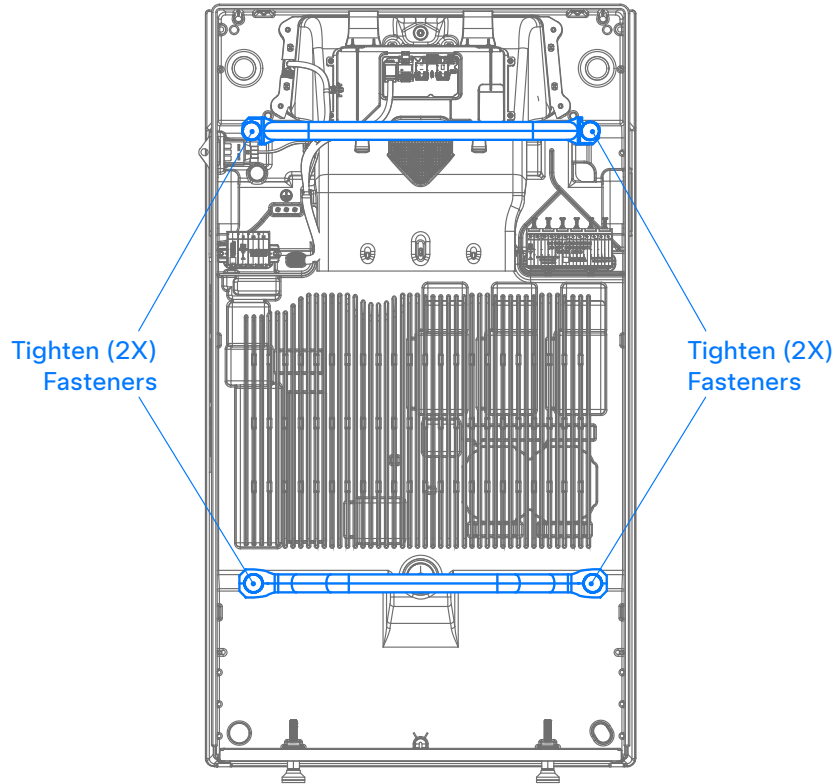

4. Confirm the leveling feet are screwed all the way in to the Powerwall.



CAUTION: The leveling feet must remain installed on Powerwall 3, regardless of whether it is wall-mounted. The leveling feet ensure the required clearance is maintained between Powerwall 3 and any surface below it.

5. Engage the Powerwall dolly with the lift handles:
 - a. Lift the Powerwall dolly, with one person holding either end.
 - b. Raise the lifting attachment and lower the Powerwall dolly, inserting the lifting plate between the Powerwall 3 feet as it is lowered, and lowering the lifting attachment so that it engages the handles.



CAUTION: Confirm the handles are fully engaged with the dolly before proceeding.



STEP 2: REMOVE POWERWALL 3 FROM PACKAGING AND TRANSPORT USING THE POWERWALL DOLLY

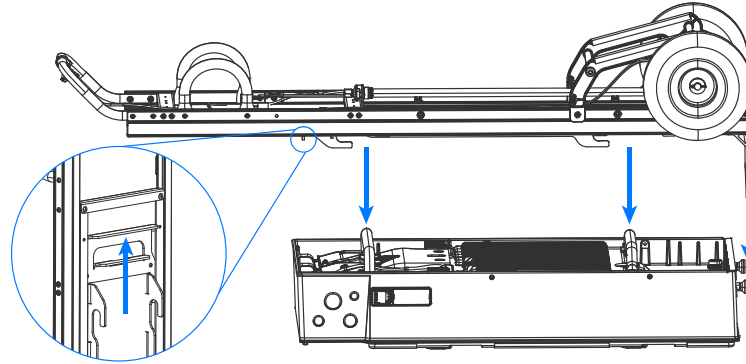

Raise Lifting Attachment

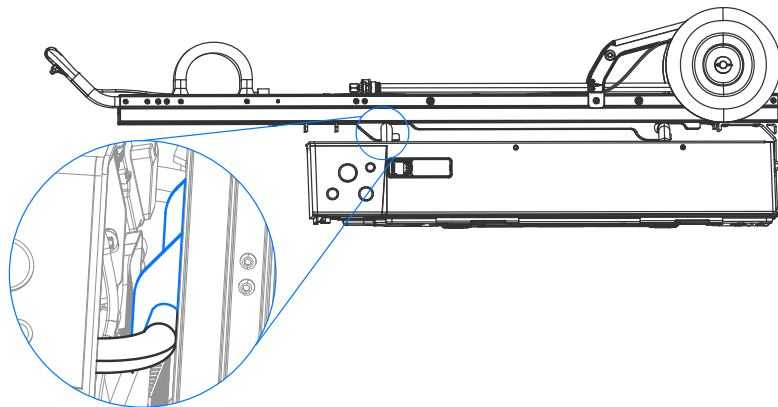

Confirm Lifting Attachment Engaging Handles

6. Place one foot on the Powerwall packaging as a pivot point, then lift Powerwall and the dolly to a standing position.



CAUTION: Powerwall 3 must be in its packaging when lifting it in this manner; the packaging ensures the corners of the enclosure are protected.



STEP 2: REMOVE POWERWALL 3 FROM PACKAGING AND TRANSPORT USING THE POWERWALL DOLLY

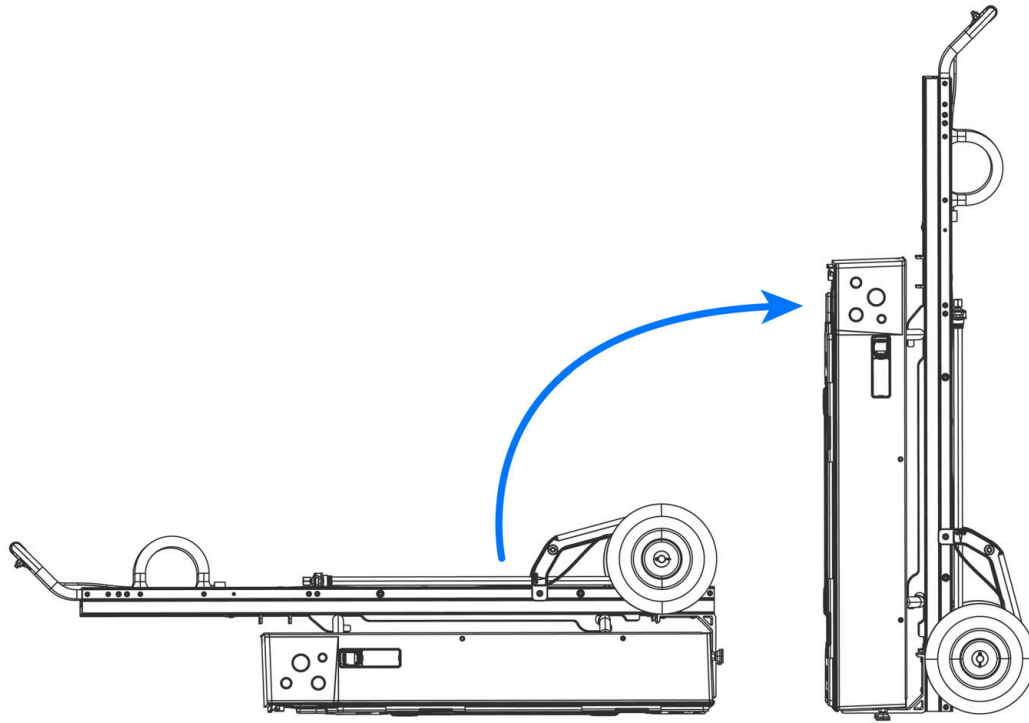

7. Remove the packaging and set it aside.
8. Position Powerwall at the mounting wall.



WARNING: Use extreme caution if using the dolly on uneven terrain, such as grass, mud, or loose gravel, or if using on a steep incline.



CAUTION: Always lower the lifting plate to its lowest position before moving the dolly with Powerwall 3 attached.

9. To raise or lower Powerwall 3:



STEP 2: REMOVE POWERWALL 3 FROM PACKAGING AND TRANSPORT USING THE POWERWALL DOLLY

- a. Tilt the dolly back 30 degrees to avoid Powerwall tilting forward or catching the wall bracket.

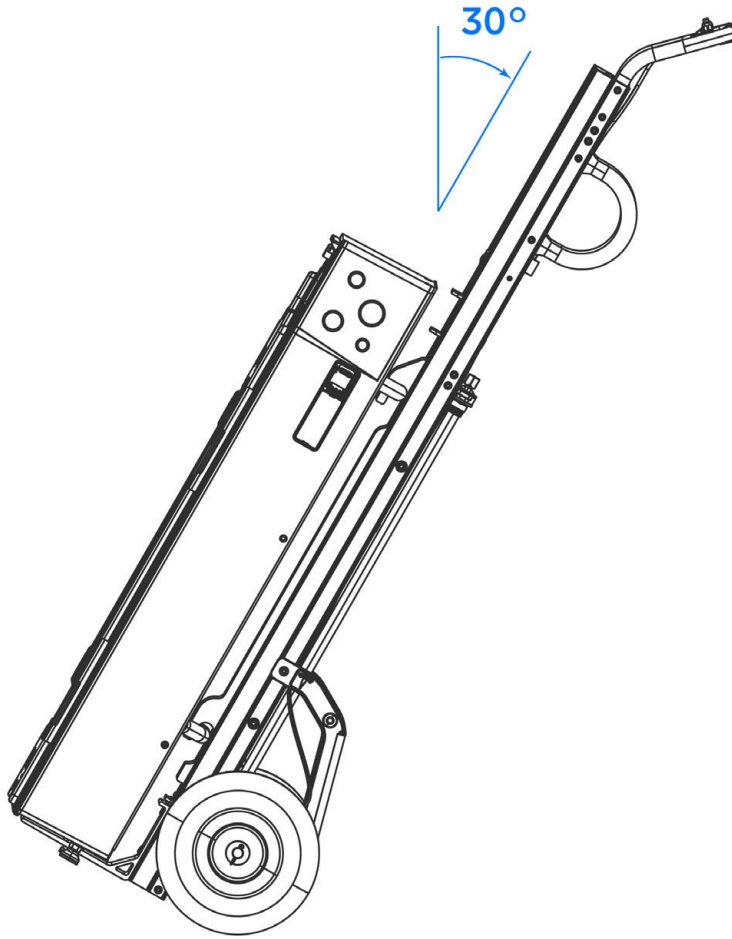

- b. Place a 3/4-inch hex nut or 19 mm drill socket on the dolly lifting screw.
- c. Connect a drill to the hex nut or drill socket, then secure the drill to the side of the dolly using the provided strap.



CAUTION: Do not use an impact drill.



STEP 2: REMOVE POWERWALL 3 FROM PACKAGING AND TRANSPORT USING THE POWERWALL DOLLY

- d. Ensure the drill is on the high torque setting (or the slowest setting), then run the drill until Powerwall has been lifted to the desired height. Run the drill in reverse to lower.

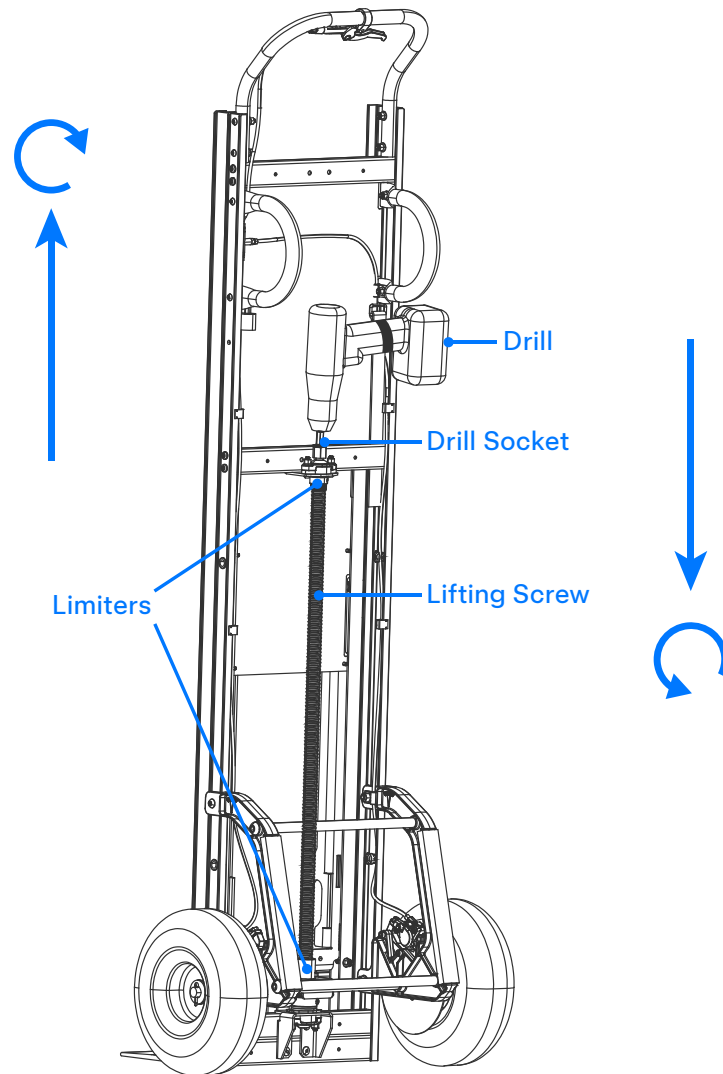

CAUTION: Be aware of the limiters on the lifting screw, and do not attempt to drive the screw beyond those limiters.



CAUTION: Only lift Powerwall 3 using the Powerwall dolly or a platform lifting tool.

10. To disengage the dolly from Powerwall 3:
 - a. Raise the lifting attachment to disengage the dolly from the handles.
 - b. Move the dolly away from Powerwall 3.
 - c. Using the drill, lower the lifting platform to its lowest position.
 - d. Remove the two lifting handles and reattach them to the dolly.



STEP 3: WALL-MOUNT POWERWALL 3 USING WALL BRACKET

1. Using a drill and level, mount the Powerwall bracket to a wall capable of supporting the full weight of Powerwall 3. See [Anchoring Details for Ground- or Wall-mounting Powerwall 3 with Wall Bracket on Existing Approved Foundation on page 82](#) for additional details on the type and number of fasteners to use.

Figure 7. Bracket Measurements Relative to Powerwall and Floor

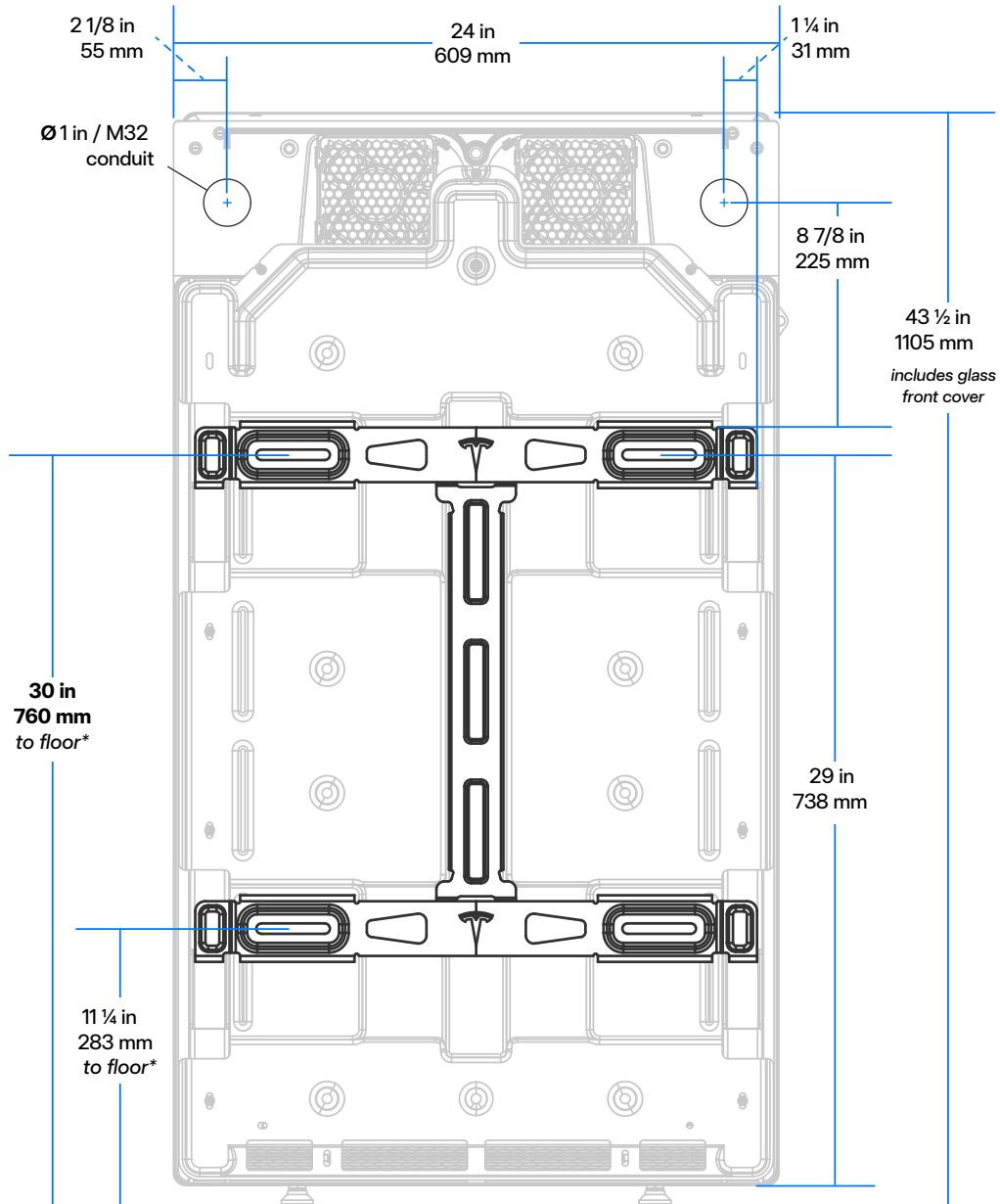



STEP 3: WALL-MOUNT POWERWALL 3 USING WALL BRACKET



WARNING: Only install fasteners in the (4) slots on the horizontal bracket segments. Do not install fasteners on the vertical (center) segment, as these are not structural mounting holes.

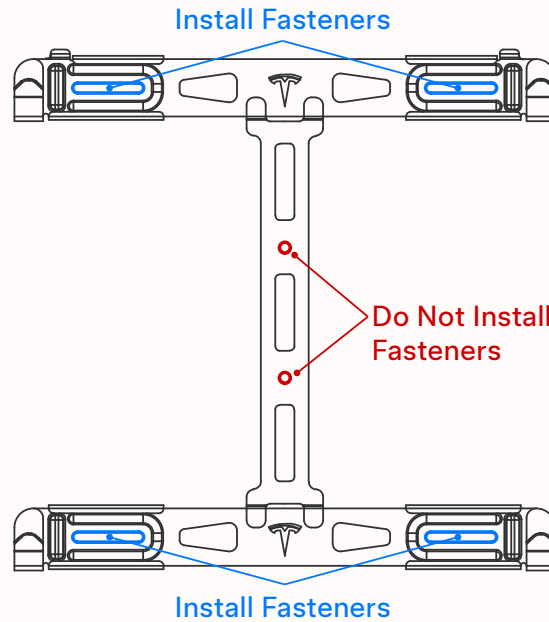

NOTE: The following diagram provides measurements for positioning rear conduit entry holes relative to the Powerwall 3 bracket (the measurements are the same for both knockouts).

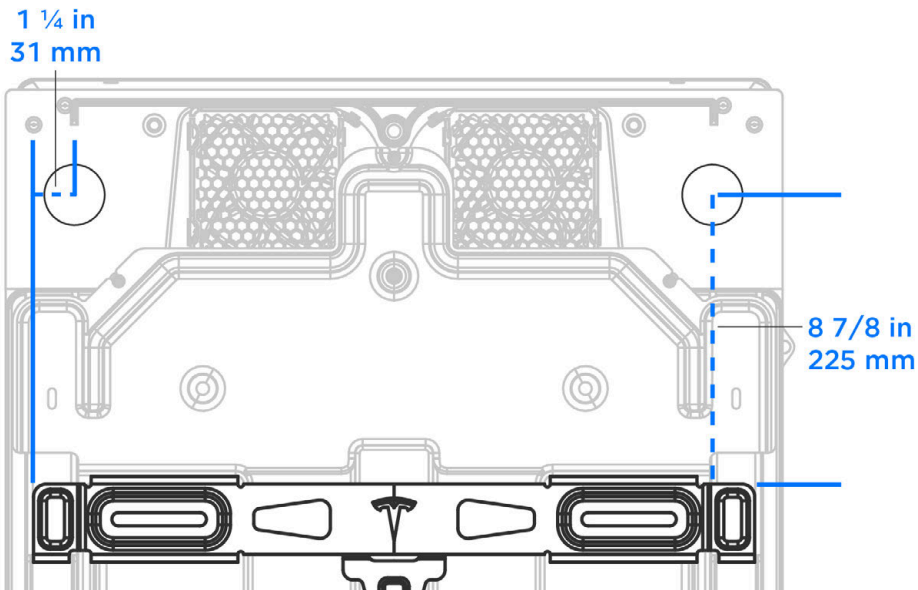



STEP 3: WALL-MOUNT POWERWALL 3 USING WALL BRACKET

2. Move the dolly toward the wall, positioning Powerwall so that the mounting cleats are just above the flanges on the bracket.

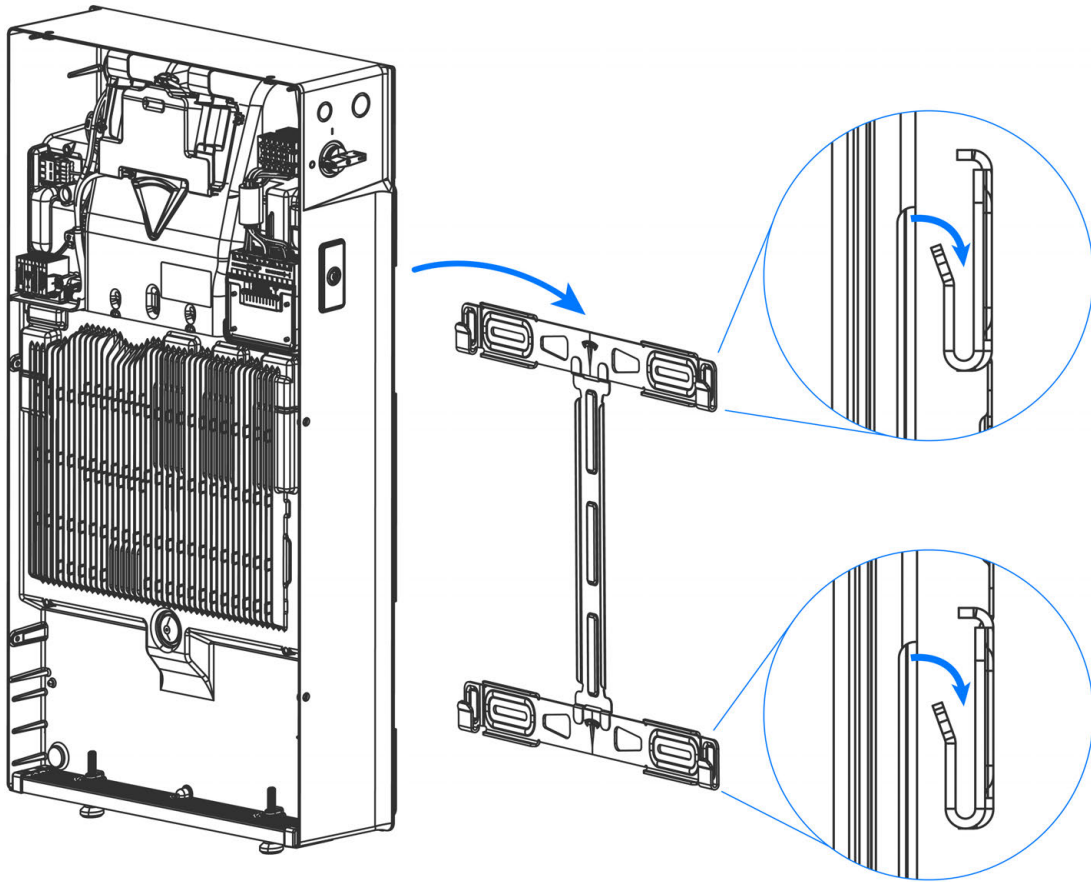

3. Lower Powerwall until both the upper and lower sets of cleats engage the flanges on the bracket.



CAUTION: Confirm Powerwall 3 is fully seated on all four cleats before proceeding.

4. If ground-mounting Powerwall, use a 17 mm wrench to adjust the leveling feet until Powerwall is level. The unit should be level within ± 2 degrees side-to-side and within ± 5 degrees front-to-back.



NOTE: The top of each foot must be visible above the threaded boss; do not unscrew the foot so far that the top is no longer visible.



STEP 4: MAKE SOLAR PV CONNECTIONS



NOTE: See [Powerwall 3 AC and PV Wiring on page 85](#) for wiring specifications.



CAUTION: Only connect PV wires to the integrated DC isolator as described in this step. Do not attempt to modify factory-installed wiring or connect PV wires to any other terminals.

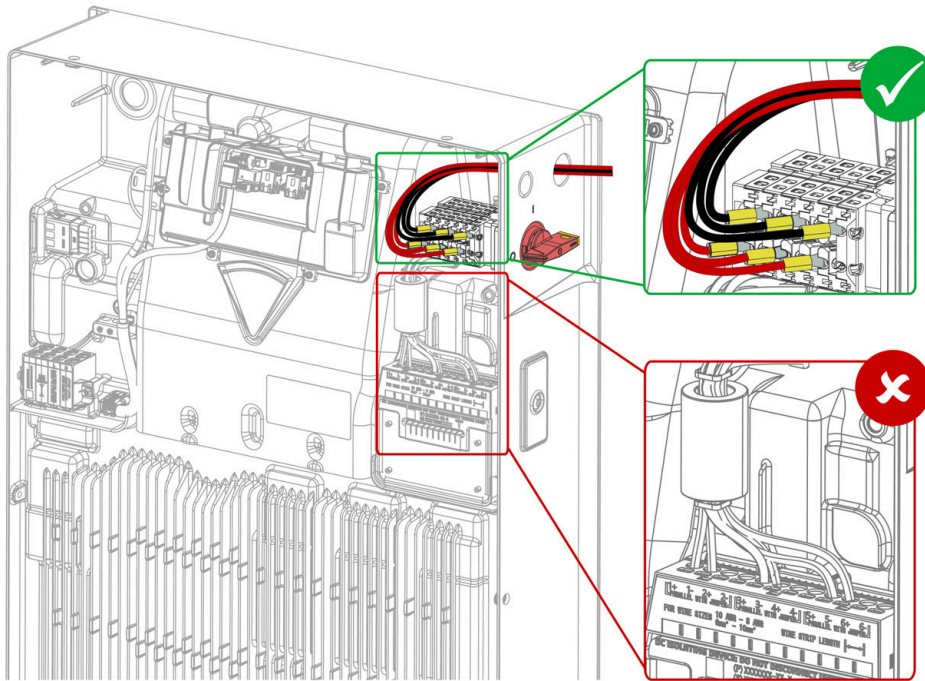

NOTE: If there are more than three PV strings, strings can be combined upstream of Powerwall 3 so long as the voltage and current ratings of the system do not exceed the capabilities of Powerwall 3.

1. Before terminating any conductors inside Powerwall 3, turn the Powerwall 3 switch OFF to shut the system down, then turn the integrated DC isolator OFF. See [Powerwall 3 Switch Locking Mechanisms on page 100](#) for instructions to lock the integrated DC isolator in the OFF position.

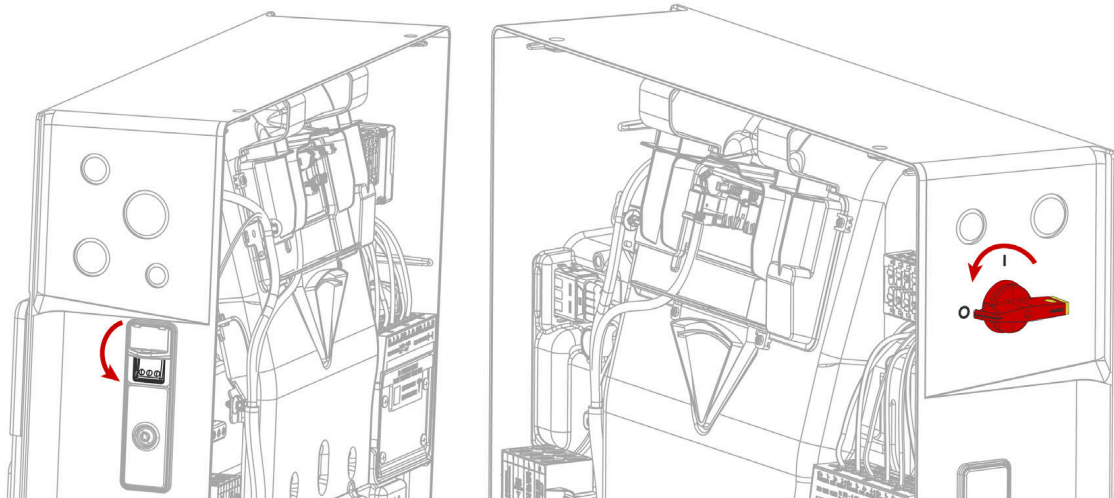



STEP 4: MAKE SOLAR PV CONNECTIONS



WARNING: Before proceeding, confirm both switches are OFF and there is a lack of voltage at the PV terminals.

2. Clear out any debris that may be present in the PV wiring terminals.



WARNING: Metal debris like loose wires or metal shavings could create a high voltage risk when Powerwall is turned on.

3. Route the PV conductors and PV array Protective Earth into the enclosure, through the conduit or cable gland. Create a service loop with extra wiring.
4. Connect the PV array Protective Earth to an equipment grounding terminal in Powerwall:
 - a. Strip the conductor insulation up to 19 mm.
 - b. Insert the grounding conductor in an equipment grounding terminal and tighten the screw in the Earth terminal to 4 Nm.
5. Starting with MPPT 1:



NOTE: If MPPT 1 is not wired first, it will not be possible to access that wiring terminal once conductors are connected to MPPT 2 or MPPT 3.

- a. Strip the conductor insulation so that the ends of the copper strands are visible.
- b. Crimp the following insulated forked terminal onto the end of the conductor; a ratcheting die crimping tool is strongly recommended.
 - TE Connectivity P/N 165015 (4 - 6 mm² wire size)



CAUTION: Forked terminals are required for PV wiring. Do not connect bare wires or any type of forked terminal other than those listed above due to increased risk of poor electrical connection.



CAUTION: Do not attempt to connect multiple wires to a single forked terminal. If the system has more than three PV strings, combine strings upstream of Powerwall 3 and connect no more than three strings to the integrated DC isolator.



NOTE: Ensure the ends of the copper strands are visible at the bottom of the fork, indicating the conductor is making strong contact with the forked terminal.

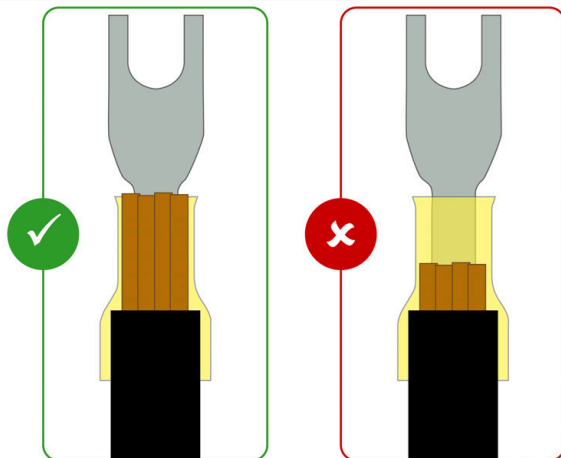

- c. Insert the forked terminal into the wiring terminal and, using a Philips PH2 torque screwdriver (see [Required Tools on page 25](#) for additional details), tighten the screw in the PV wiring terminal to 1.6 Nm.



STEP 4: MAKE SOLAR PV CONNECTIONS

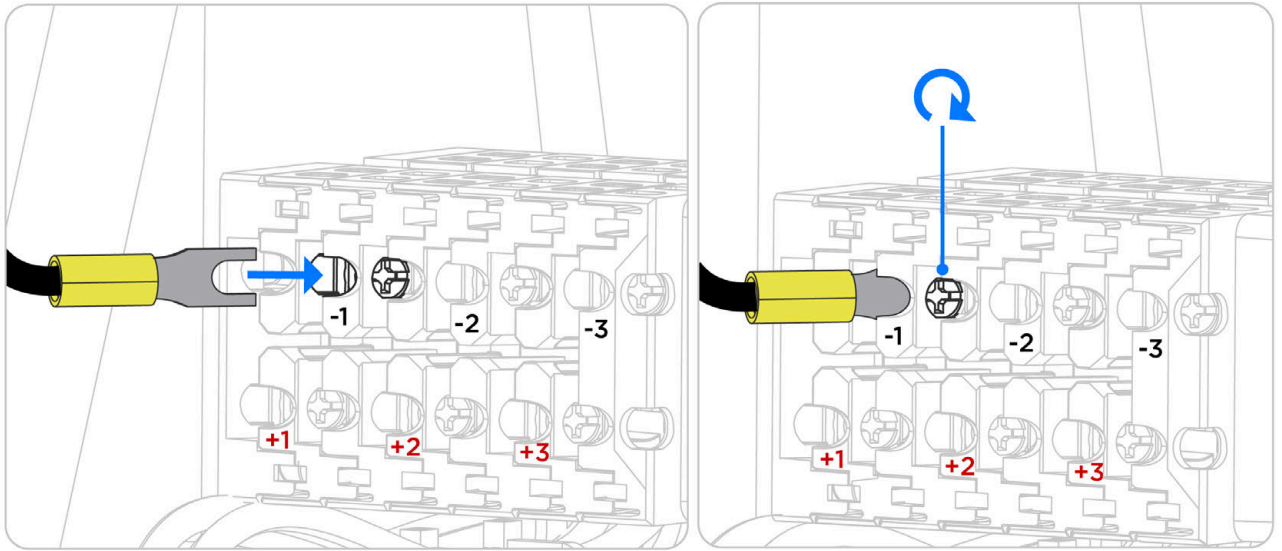

6. Repeat Step 5 for MPPT 2, then MPPT 3.

Figure 8. Powerwall 3 PV Wiring Connected to Integrated DC Isolator

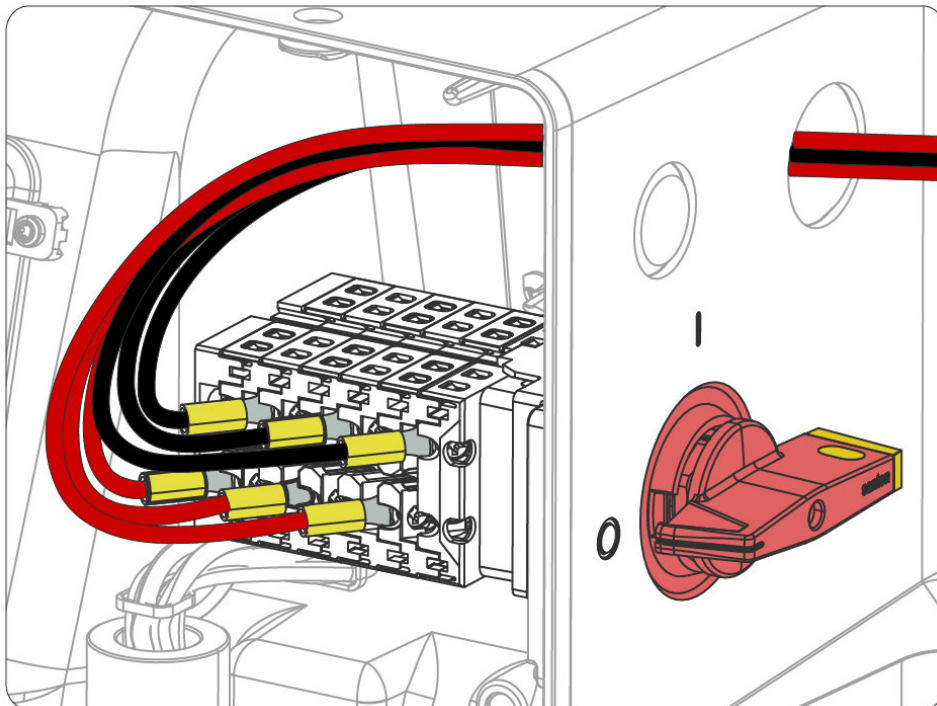

CAUTION: Before energizing the system, use a multimeter to confirm the polarity of the PV strings is as pictured above (positive strings in bottom row of terminals, negative strings in top row of terminals). Reversed polarity of the PV strings may cause damage to the system.



STEP 4: MAKE SOLAR PV CONNECTIONS

Figure 9. Powerwall 3 PV Wiring and Protective Earth

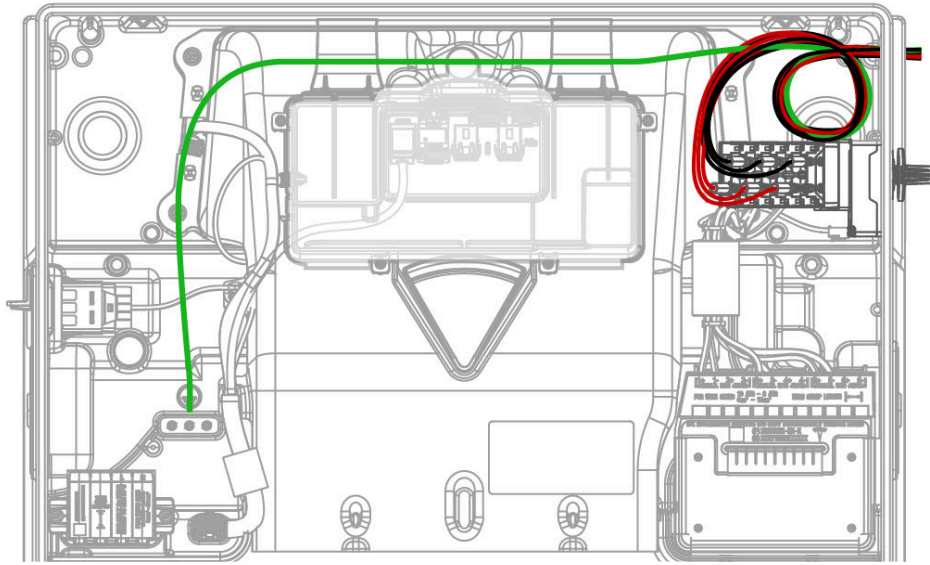

CAUTION: All PV strings must pass through the integrated DC isolator. Do not attempt to connect PV strings via any other terminals. For more information on the integrated DC isolator, see [Appendix G: Shutting Down Powerwall 3 on page 110](#).



CAUTION: Any wire routing must be done through the wire management tabs at the top of the enclosure. Do not route loose wires through the front of the enclosure or over the Tesla Asset Controller.



STEP 5: INSTALL BACKUP GATEWAY 2

Mount the Backup Gateway

1. Using a hole saw, drill out the necessary cable access holes from the Backup Gateway.

Figure 10. Top / Bottom (above) and Back (below) Cable Access Drill Guides

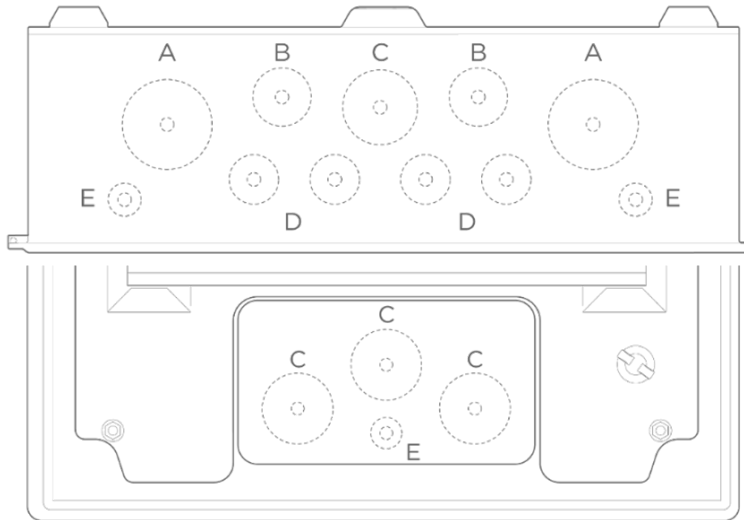

Drill Guide Diameters

Drill Guide Diameters	
A	M40, expandable to M50
B	M25
C	M32
D	M20
E	M12



CAUTION: When Backup Gateway is installed outdoors, top cable entry is prohibited as it may result in water ingress.



STEP 5: INSTALL BACKUP GATEWAY 2

2. Using a drill and level, mount the Backup Gateway enclosure.



NOTE: Leave a minimum clearance of 50 mm above the Backup Gateway.

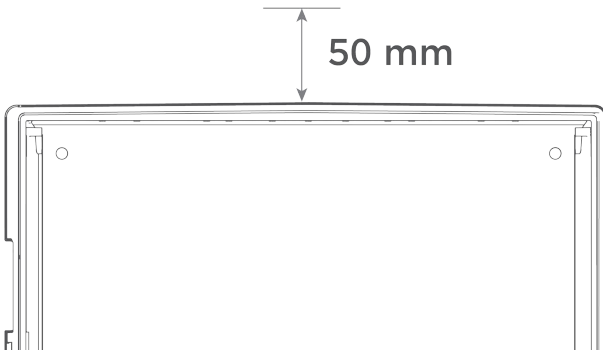

NOTE: The enclosure must be installed in the orientation shown below. Do not mount the Backup Gateway enclosure horizontally or upside down.



CAUTION: To ensure IP55 ingress rating is maintained, the enclosure must only be mounted at these three points.

Figure 11. Backup Gateway Enclosure Mounting Holes

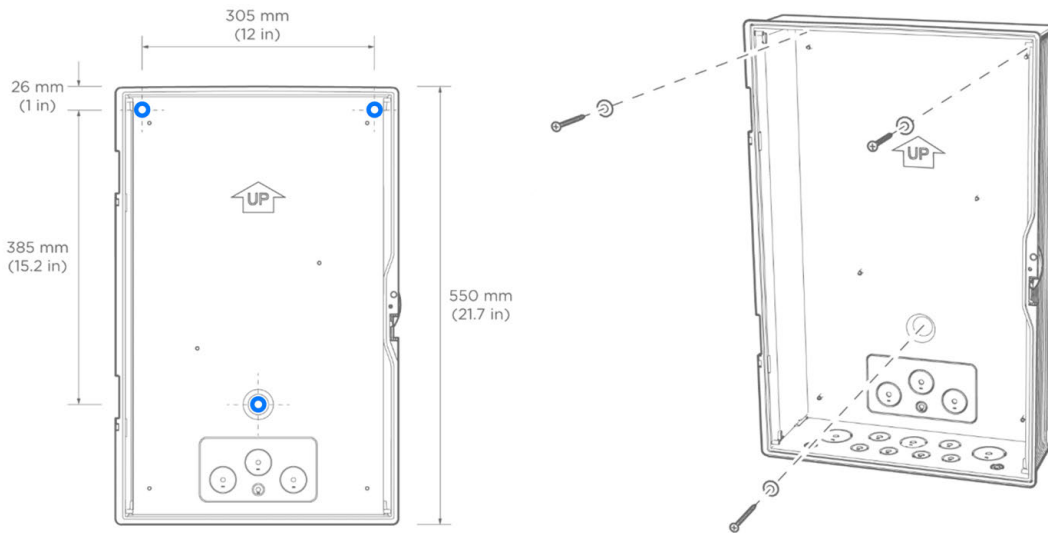

CAUTION: The sealing washers must be installed to guarantee IP55 ingress rating.



STEP 5: INSTALL BACKUP GATEWAY 2

3. Install the Backplate Assembly in the enclosure, orienting it for bottom or top cable entry. Attach it to the five (5) studs using the five (5) supplied 8 mm nuts. Use a torque wrench with 8 mm socket to tighten the nuts to 6 Nm.

Figure 12. Backplate Orientation for Bottom Cable Entry (left) or Top Cable Entry (right)

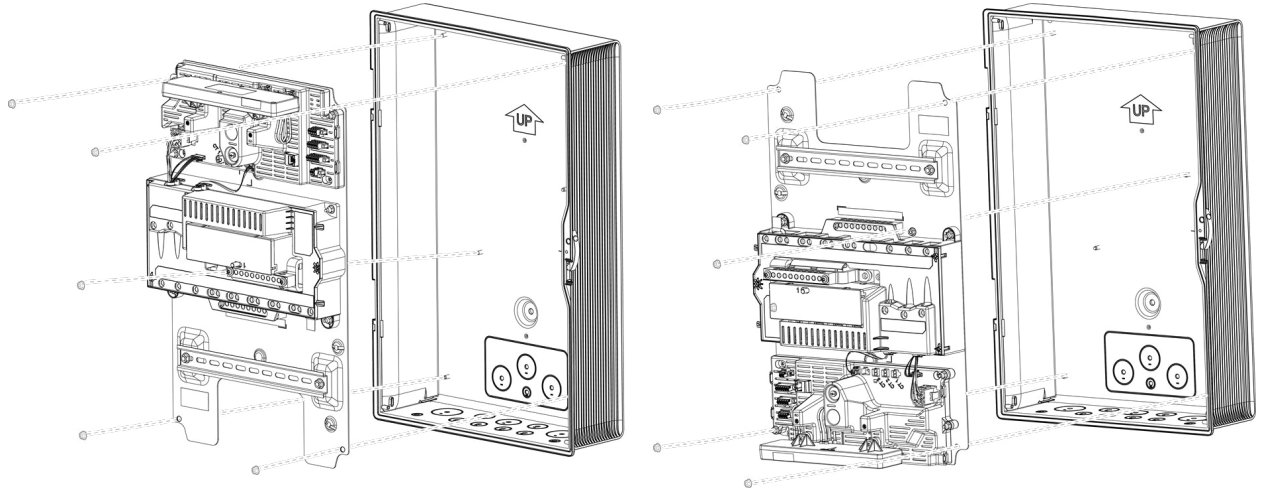

4. Locate the Backup Gateway serial number on the label on the dead front cover. Record the serial number for reference.

Verify Neutral-Earth Bonding Scheme

Proper earth connection and Neutral-to-Physical Earth (N-PE) bonding is required for safe operation of the Powerwall system and for compliance with local code requirements. The correct Neutral-to-Earth bonding scheme must be maintained even when the system is disconnected from the grid.

The neutral conductors must not be broken in Australia and New Zealand on **TN-C-S** networks in off-grid operation. Neutral and Protective Earth (PE) conductors are separated at the main switchboard, and the MEN (Multiple Earthed Neutral) link is maintained at a single point of connection between neutral and protective earth. With the **N-N Jumper Bar** installed, neutral will not be broken during off-grid operation.

Figure 13. Neutral Conductors are not disconnected in Off-Grid Operation with Factory Installed N-N Jumper Bar

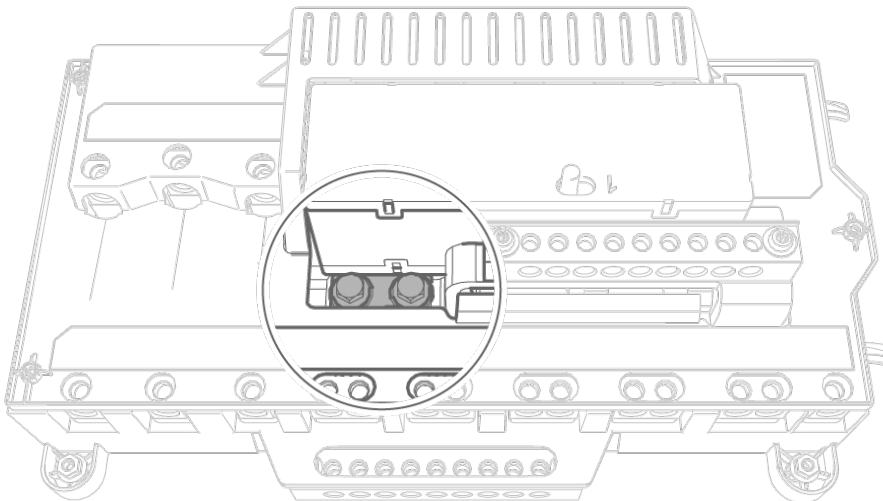



STEP 5: INSTALL BACKUP GATEWAY 2

 **WARNING:** Incorrect earthing or Neutral-to-Protective Earth (N-PE) bonding presents a risk of electrical shock or damage to equipment. Verify that the system is properly earthed and that the correct Neutral-to-Earth bonding scheme meets regional and local requirements.

Make AC Power Connections to Supply and Load Panels

In each of the following steps:

- Strip the ends of the wires, install wire ferrules, and insert into the corresponding Backup Gateway terminal lugs.
 - Using an M3 Allen bit, tighten the lugs to 4 Nm.
1. Connect the main service conductors to the Backup Gateway Supply terminals according to [Conductor Connections for Single Phase \(left\) and Three-Phase \(right\) on page 51](#).
 2. Connect the home load panel conductors to the Backup Gateway terminals according to the table on the following page.
 3. Depending on the quantity of Non-Backup circuits, a Non-Backup panel will be required. Connect the conductors (Line(s), Neutral, and Protective Earth) from the Non-Backup panel to the Backup Gateway's Non-Backup terminals.

Non-Backup circuits include: 3-phase PV inverters, 3-phase loads, large single-phase loads.

4. Connect the non-backup panel conductors to the Backup Gateway Non-Backup terminals according to the table on the following page. Any circuits connected here will not be powered when disconnected from the grid. During on-grid operation, these circuits are still metered by the internal site metering with no additional metering hardware required.

 **WARNING:** Installing 3-phase equipment on the backup circuit may result in equipment damage.

 **WARNING:** Always ensure all equipment is safely de-energized and locked out prior to working, to prevent risk of electric shock. To avoid shock hazard, never power on the system without a connection to Earth at the Gateway. The Earth bar and backplate voltage may float when ungrounded. If conducting earth loop impedance testing, ensure the Gateway always has a suitable Earth connection.

 **WARNING:** Incorrect wiring of AC conductors presents a risk of electrical shock or damage to equipment. Before energizing the system, ensure all connections are made correctly according to the instructions in this document and in accordance with local wiring codes and regulations.

 **CAUTION:** To ensure IP55 ingress protection, appropriate fittings and/or cable glands must be used to secure all cables passing into the enclosure.

Refer to [Appendix B: Wiring Reference on page 85](#) for all wiring requirements and recommendations, including wire colors and gauges.

Refer to [Appendix C: System Wiring Diagrams on page 92](#) for example system wiring diagrams.



STEP 5: INSTALL BACKUP GATEWAY 2

Table 2. Conductor Connections for Single Phase (left) and Three-Phase (right)

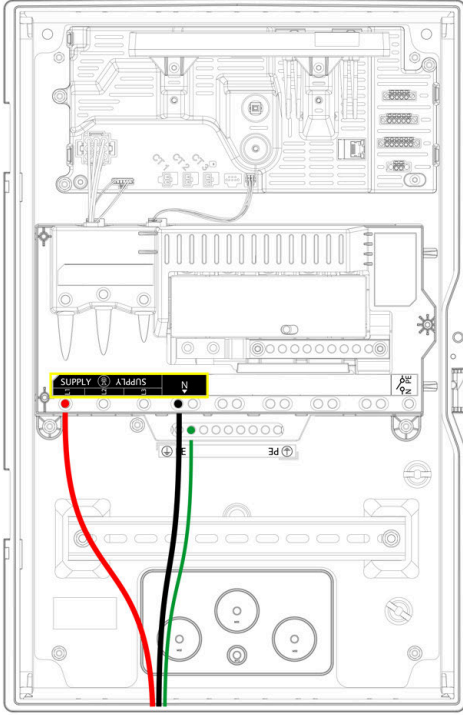
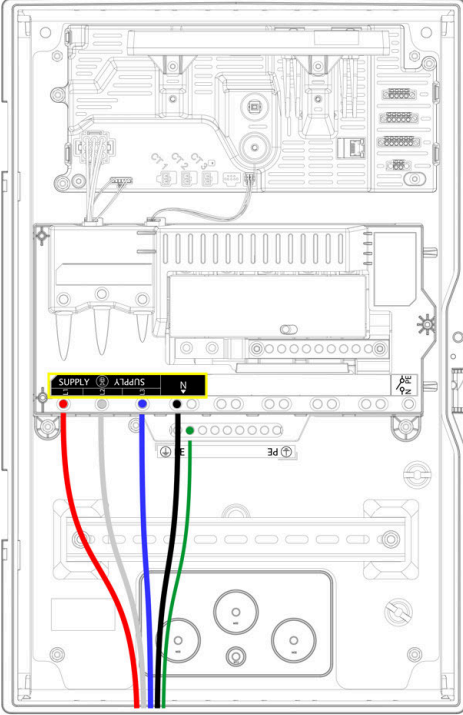
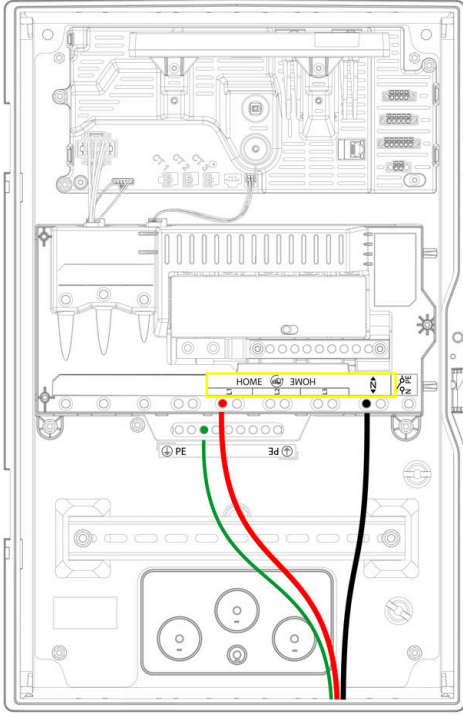
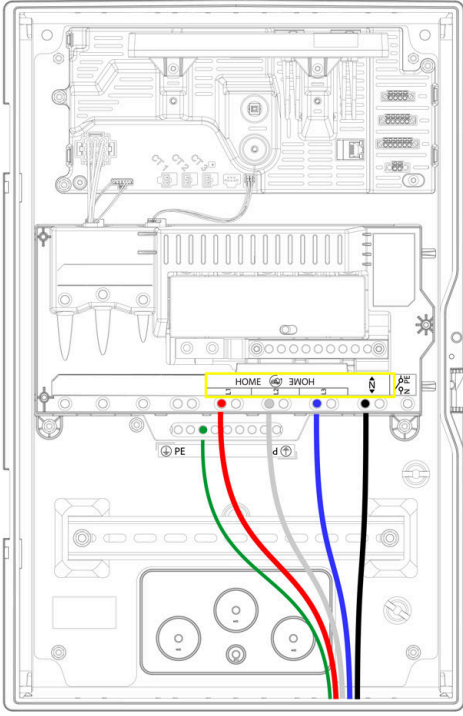
	Single Phase	Three-Phase
Supply Connections	 <p>The diagram shows a single-phase supply connection. A red wire is connected to the 'SUPPLY' terminal, a black wire to the 'N' terminal, and a green wire to the 'PE' terminal. The 'SUPPLY' terminal is highlighted with a yellow box.</p>	 <p>The diagram shows a three-phase supply connection. A red wire is connected to the 'SUPPLY' terminal, a blue wire to the 'A1' terminal, a black wire to the 'N' terminal, and a green wire to the 'PE' terminal. The 'SUPPLY' terminal is highlighted with a yellow box.</p>
Home Load and Backup Connections	 <p>The diagram shows home load and backup connections for single phase. A red wire is connected to the 'HOME' terminal, a black wire to the 'N' terminal, and a green wire to the 'PE' terminal. The 'HOME' terminal is highlighted with a yellow box.</p>	 <p>The diagram shows home load and backup connections for three phase. A red wire is connected to the 'HOME' terminal, a blue wire to the 'A1' terminal, a black wire to the 'N' terminal, and a green wire to the 'PE' terminal. The 'HOME' terminal is highlighted with a yellow box.</p>



STEP 5: INSTALL BACKUP GATEWAY 2

Non-Backup Connections

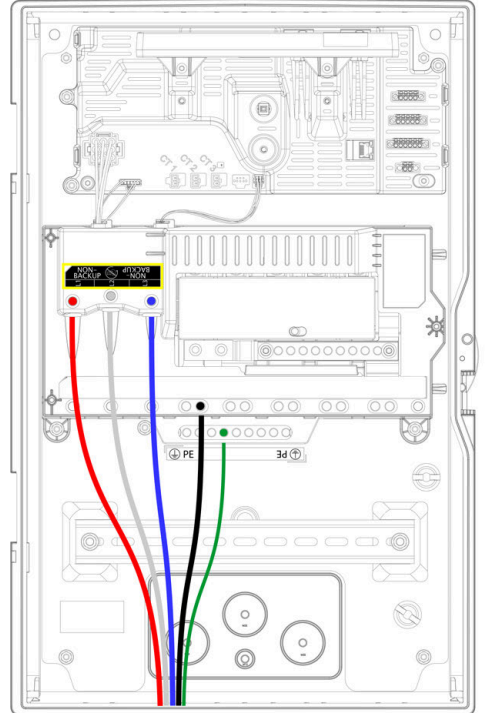
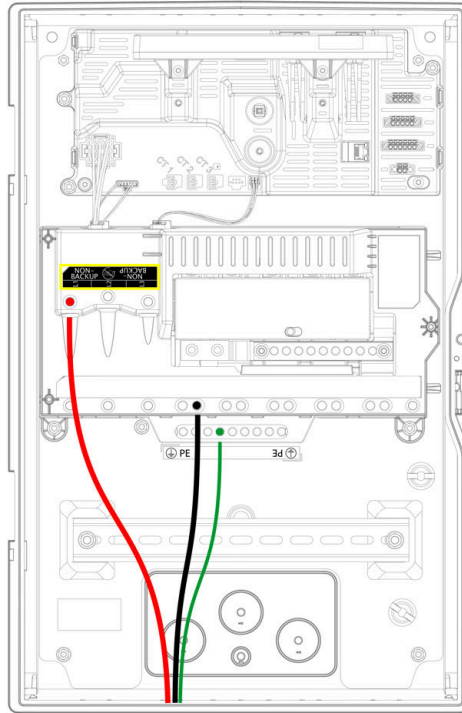

Terminal	Maximum Wire Gauge	Strip Length	Torque
Supply	35 mm ²	12.5 mm	4 Nm
Non-Backup	35 mm ²	12.5 mm	4 Nm
Home (Backup)	35 mm ²	12.5 mm	4 Nm
Neutral terminal bar	25 mm ²	12.5 mm	4 Nm
PE terminal bar	25 mm ²	12.5 mm	4 Nm

Install Powerwall and Generation Breakers in the Backup Gateway

1. Install the Powerwall and generation circuit breakers on the DIN rail, and connect using an appropriately rated DIN rail circuit breaker busbar.



WARNING: All Powerwalls in the system must be installed on the 'Backup' ('Home') side of the Backup Gateway's relay.

2. Connect the line conductors from the bussed generation circuit breakers to the Backup Gateway's Backup terminals (see figure below). These conductors must be appropriately rated to carry the current of the main supply fuse.
3. Connect Neutral and PE conductors from Powerwall and generation circuits to the Neutral and PE wiring bars, respectively.



STEP 5: INSTALL BACKUP GATEWAY 2

Figure 14. Single Phase Wiring Example

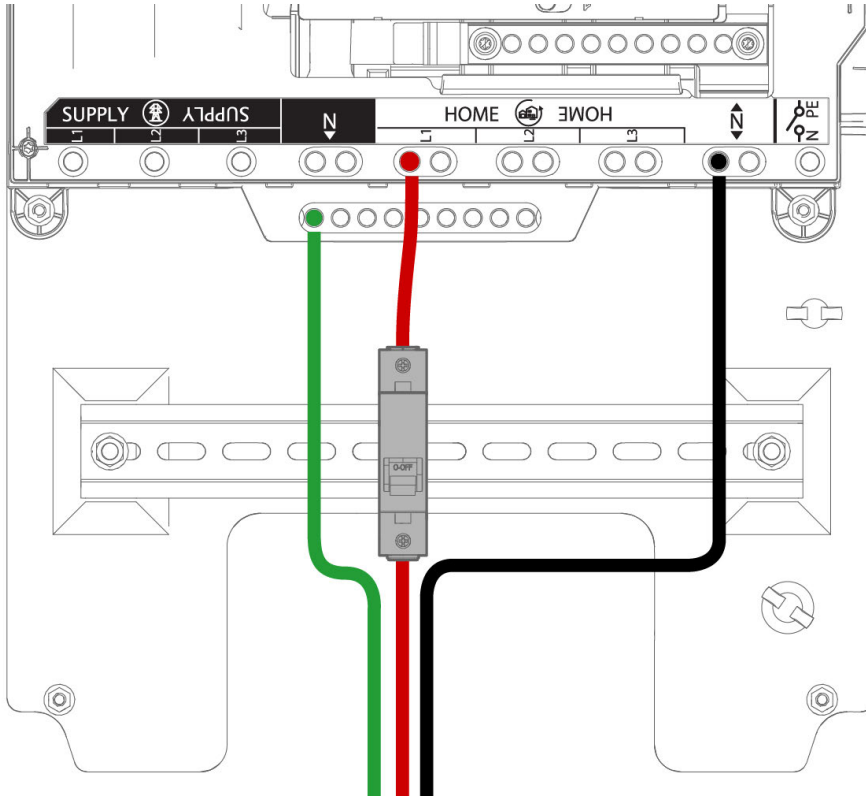

Design Considerations



CAUTION: If installing greater than 100 A of generation, a separate overcurrent protection (such as a generation sub-board) is required to maintain maximum current rating of the Backup Gateway.

The Backup Gateway 2 can accommodate up to nine (9) 1-pole MCB slots on the DIN rail for generation circuits and fuse carrier(s).

Select the appropriate Powerwall 3 breaker size depending on desired power output (configured in Tesla One).

Breaker Size	Power Output
32 A	5 kW
50 A	10 kW
63 A	11.04 kW



NOTE: A 30 mA Residual Current Device (RCD) or Residual Current Circuit Breaker with Overcurrent Protection (RCBO) is typically not compatible with solar PV inverters (such as Powerwall 3) due to environmental conditions and weather exposure to solar panels. In lieu of an RCD / RCBO, follow local code to install mechanical protection around AC conductors.

Configuring Powerwall(s) on Three-Phase Installations

- When installing multiple Powerwalls, they must be distributed evenly across the three phases. Installation must meet local generation imbalance rules.



STEP 5: INSTALL BACKUP GATEWAY 2

- During the commissioning process, the **Backup Phase** will be selected (L1, L2, or L3). During an outage, the system will provide backup power only to loads on this phase, and Powerwalls on other phases will not operate. Ensure that all critical loads in the Home Load Panel are connected on the desired Backup Phase.
- **To ensure Powerwall charges from solar production, the single-phase PV circuit(s) must be installed on the same phase as Powerwall(s).**

 **WARNING:** Installing 3-phase PV inverters or 3-phase equipment on the Backup side may result in equipment damage during off-grid operation. 3-phase PV inverters and 3-phase equipment should always be installed on the Non-Backup side of the Backup Gateway. The only exceptions to this rule are the Tesla Wall Connector or sockets feeding Tesla Mobile Connectors (please see the [Vehicle Charging During Power Outage](#) page for more information). The Powerwall system's backup phase should be connected to L1 of the Wall Connector or Mobile Connector socket.

Inverter Configuration

During backup operation, the Gateway will shift the system frequency to control the power output of solar inverters. Therefore, all solar inverters connected to the Backup terminals should be configured for the local grid code. This ensures that the inverter will respond correctly to frequency curtailment efforts. If the inverter is not compliant with the grid code requirements, it might not perform as expected during Backup operation. This could lead to hardware damage due to over-voltage. Please see more information regarding backup operation on our [website](#).



STEP 6: CONNECT POWERWALL 3 TO BACKUP GATEWAY

1. Before terminating any conductors inside Powerwall 3, turn the Powerwall 3 switch OFF to shut the system down, then turn the integrated DC isolator OFF.

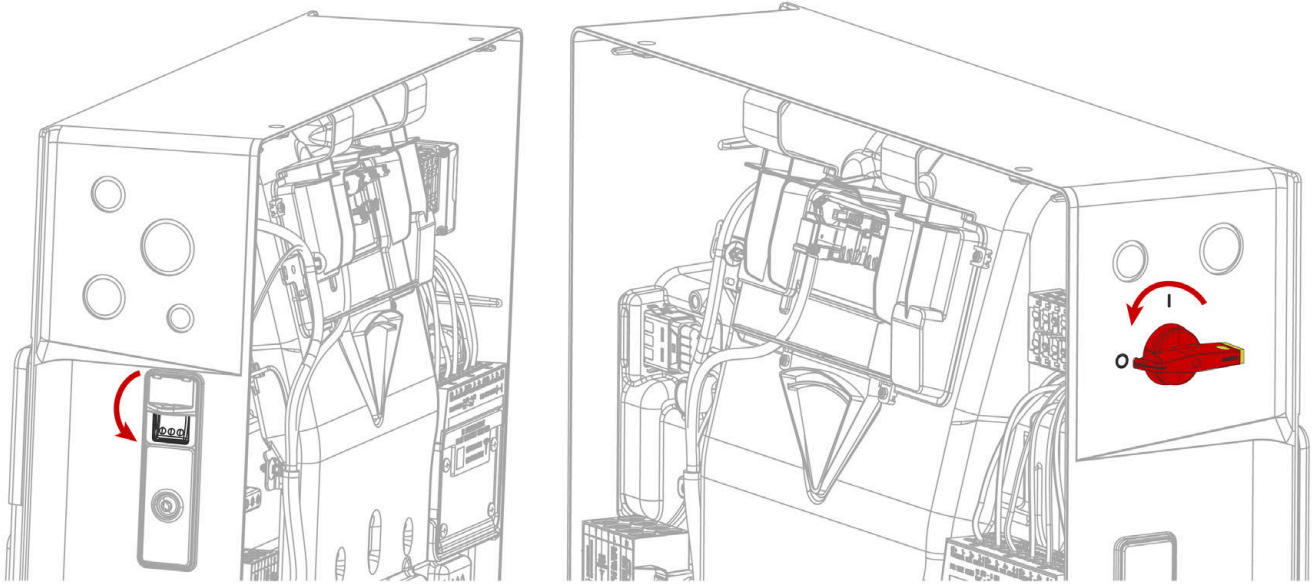

WARNING: Before proceeding, confirm both switches are OFF and there is a lack of voltage at the AC and PV terminals.

2. Run the 4-conductor communication cable from the Backup Gateway through the conduit or cable gland and pull it into the Powerwall 3 wiring compartment.

CAUTION: At Powerwall 3, Tesla recommends routing the communication wiring into the left side of the enclosure; always use the wire management tabs to ensure wires do not block the Tesla Asset Controller. Do not route loose wires through the front of the enclosure.

NOTE: See [Plan Cable Length Between Components on page 29](#) for the maximum distance between components.

3. At the Backup Gateway, strip the communication wire jacket about 76 mm and strip each conductor 8 mm.
4. At Powerwall 3, strip the communication wire jacket so that it does not extend past the edge of the fan duct and strip each conductor 8 mm.

NOTE: Stripping the communication wire jacket past the fan duct ensures the individual conductors lie flat, leaving room for the front cover to be installed.

5. At the Backup Gateway, cut back the drain wire. **The drain wire should be terminated at the Powerwall 3 ground terminal only**
6. For each connector:
 - a. Insert a cabinet tip or electronics tip slotted screwdriver (up to 3 mm) to open each connector lever.



STEP 6: CONNECT POWERWALL 3 TO BACKUP GATEWAY

- b. Insert each conductor as far as possible into the terminal and then release the connector lever to close the connector.

CAUTION: Excessive force may damage the connector; do not apply more force than is necessary to open the terminal and insert the conductor (do not lean on connectors when prying them open).

NOTE: Reference [Backup Gateway 2 Wiring on page 89](#) and [Powerwall 3 AC and PV Wiring on page 85](#) for the correct wire order in each unit's Communication connector.

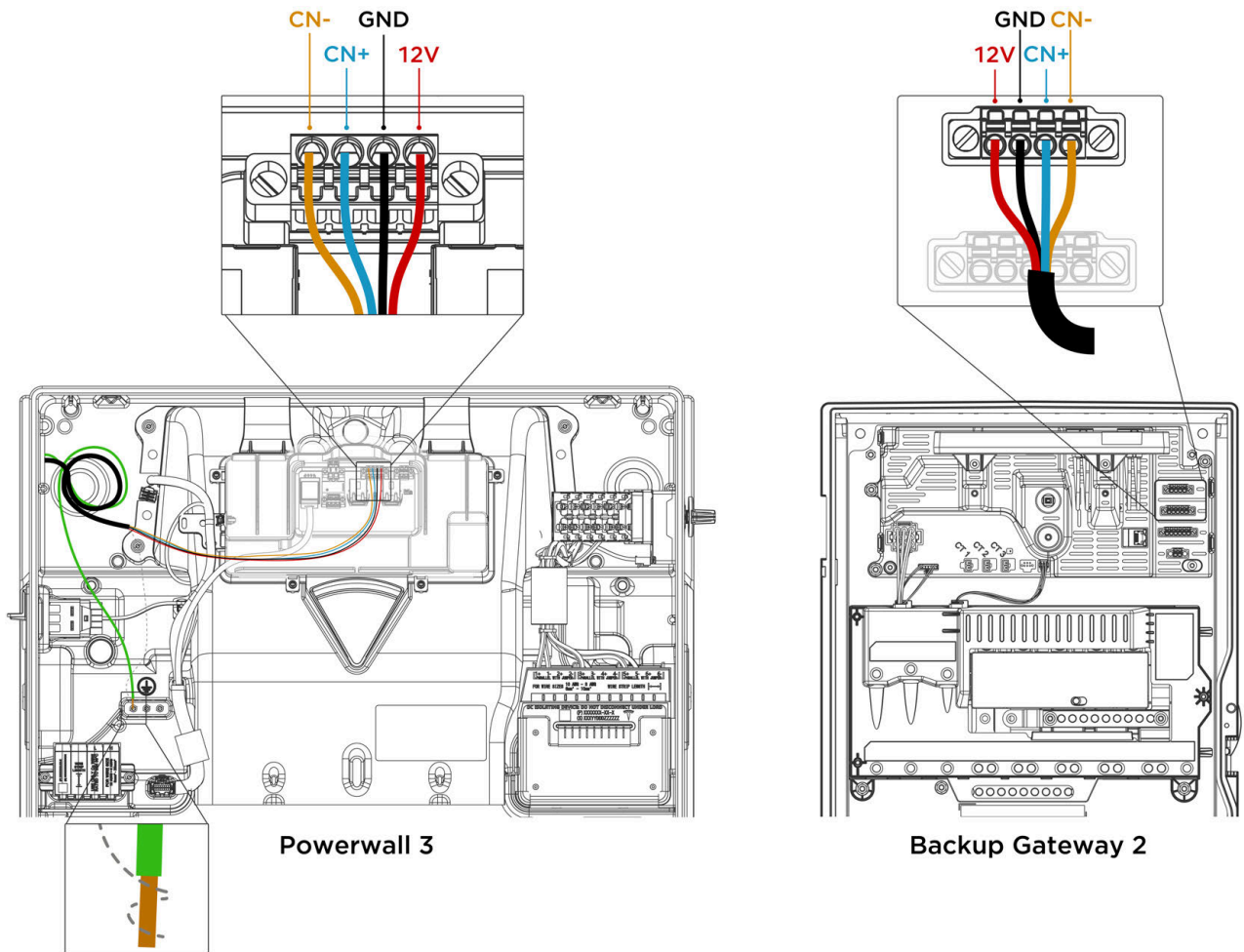

7. At the Backup Gateway, plug the 4-pin connector into the 4-pin socket labeled "Powerwall". Tighten the screws on the connector.
8. At Powerwall 3:
- Plug the 4-pin connector into the 4-pin socket.
 - Wrap the communication cable drain wire around the Protective Earth lead and insert the wires in the equipment grounding terminal. Tighten the screw to 4.5 Nm.



STEP 7: CONNECT POWERWALL 3 TO AN OVERCURRENT PROTECTION DEVICE

1. Before terminating any conductors inside Powerwall 3, turn the Powerwall 3 switch OFF to shut the system down, then turn the integrated DC isolator OFF.

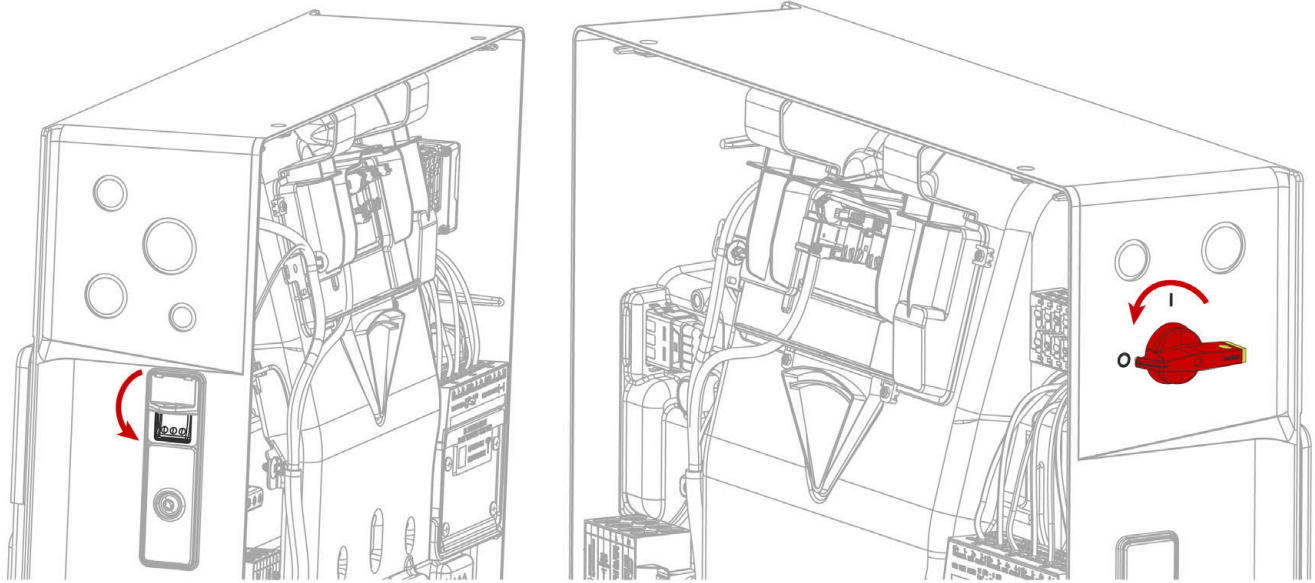

WARNING: Before proceeding, confirm both switches are OFF and there is a lack of voltage at the AC and PV terminals.

2. Turn the AC circuit breaker of the main service disconnect OFF and secure it against reconnection.
3. Connect the Powerwall 3 AC power conductors to its breaker in the Backup Gateway (see for breaker requirements and instructions to install breaker).
4. (Conduit installations only) Run conduit as needed and attach the conduit fitting to the Powerwall 3 AC wiring knockout.
5. Run the AC power conductors and the Protective Earth from the main panel through the conduit or cable gland. Route the conductors to the appropriate terminals, creating a service loop with the extra wiring.
6. Clear out any debris that may be present in the AC wiring terminals.

WARNING: Metal debris like loose wires or metal shavings could create a high voltage risk when Powerwall is turned on.

7. Connect the Powerwall 3 Protective Earth:
 - a. Strip the conductor insulation up to 19 mm.
 - b. Insert the grounding conductor in an equipment grounding terminal and tighten the screw in the Earth terminal to 4 Nm.
8. For each AC conductor:
 - a. Strip the conductor insulation up to 11 mm. Add a wire ferrule if the conductor is finely stranded.
 - b. Insert the conductor as far as possible into the terminal.

STEP 7: CONNECT POWERWALL 3 TO AN OVERCURRENT PROTECTION DEVICE

Figure 15. Insert Conductor in Terminal

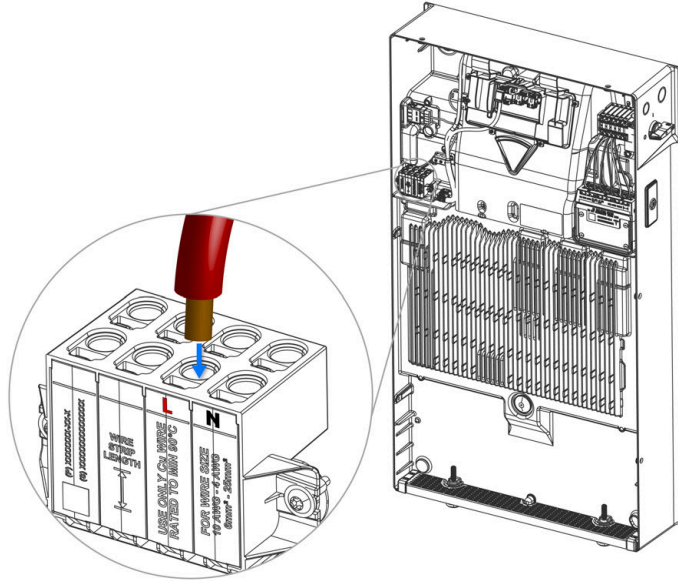

WARNING: Ensure the conductors are inserted into the round terminals and not the rectangular slots. Inserting the conductors anywhere other than the round terminals will result in poor wire termination.

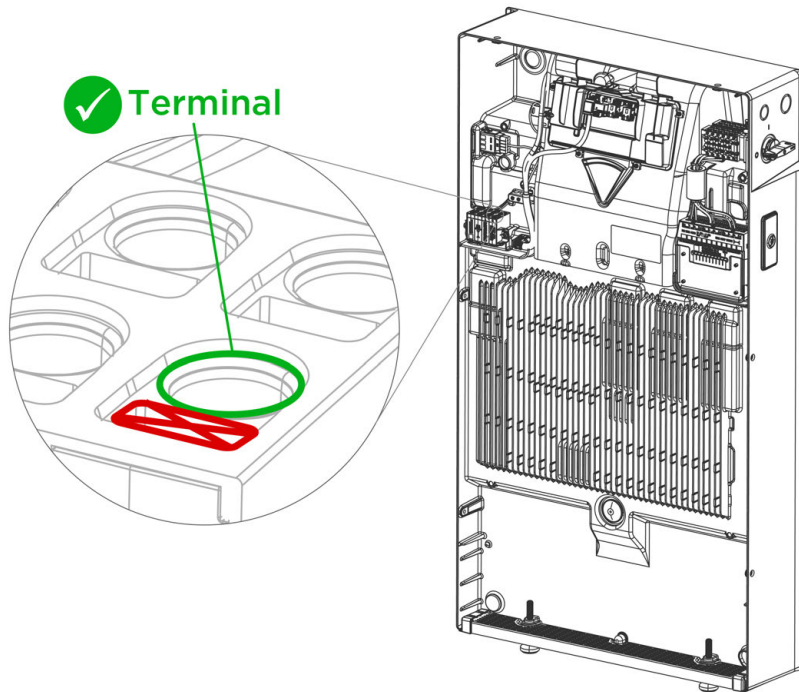

- c. Perform a pull test to ensure the conductor is fully seated in the terminal. Push the conductor back in after the pull test.

STEP 7: CONNECT POWERWALL 3 TO AN OVERCURRENT PROTECTION DEVICE

Figure 16. Powerwall 3 AC Wiring

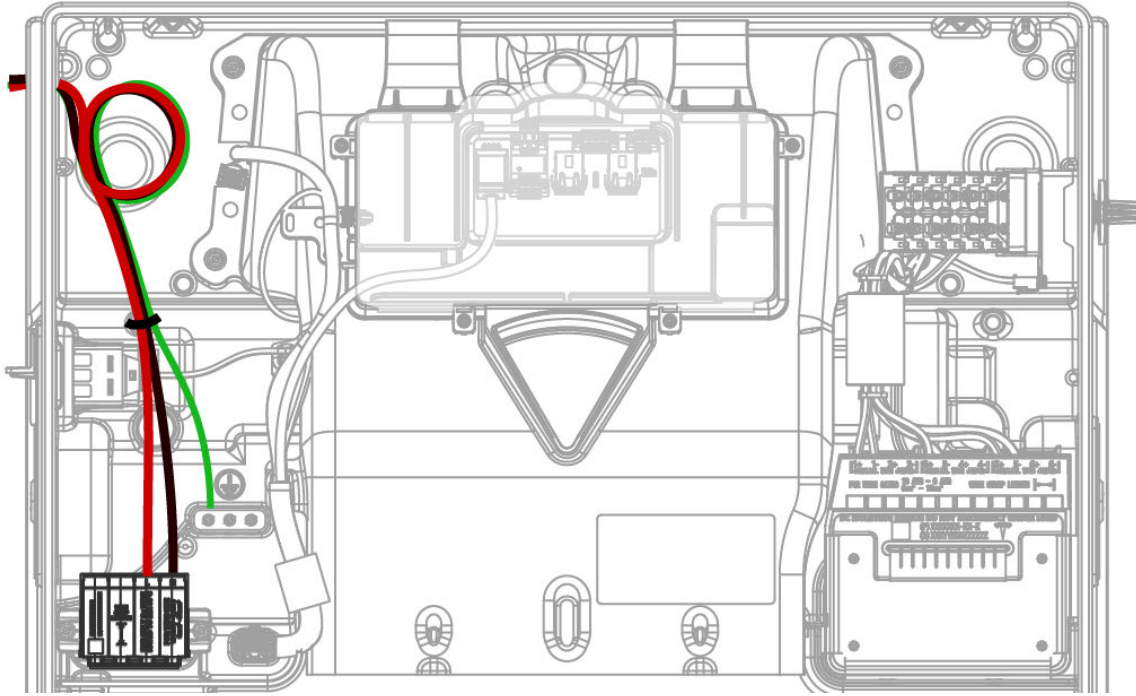

CAUTION: Any wire routing must be done through the wire management tabs at the top of the enclosure. Do not route loose wires through the front of the enclosure or over the Tesla Asset Controller.

- d. After installing the AC conductors and Protective Earth, gather them and secure them with the provided cable tie as shown above.



STEP 7: CONNECT POWERWALL 3 TO AN OVERCURRENT PROTECTION DEVICE



NOTE: If a conductor must be removed from the connector, insert a cabinet or electronics tip slotted screwdriver (up to 4.5 mm) into the actuation shaft to open the terminal. Pull the conductor free, then remove the screwdriver.

Figure 17. Spring Terminal with Screwdriver and Insert Conductor in Terminal

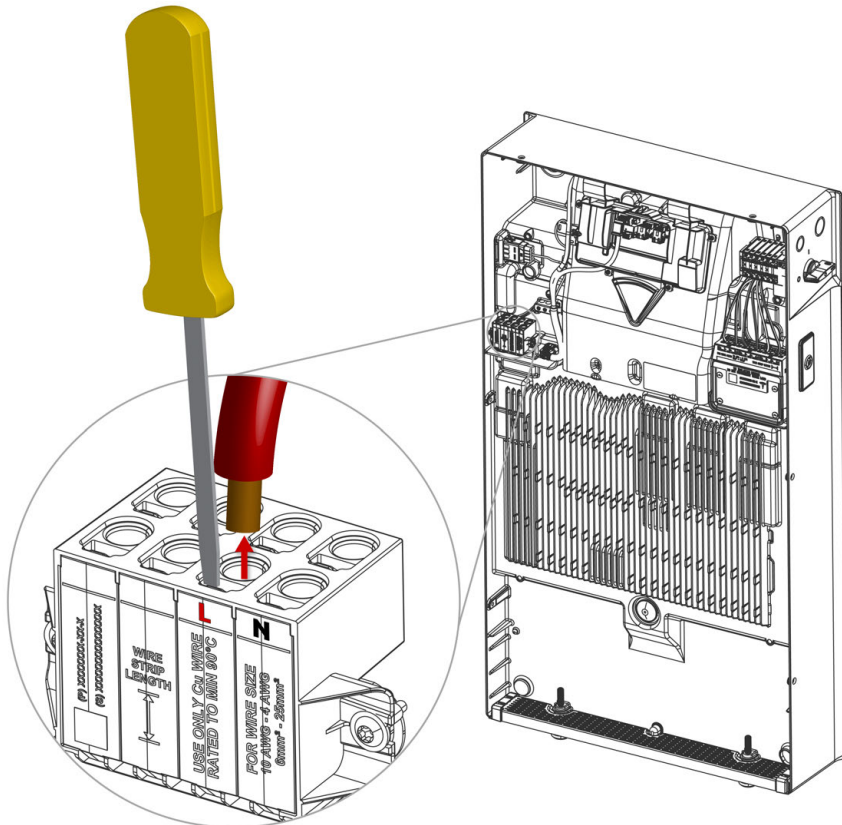

- 9. On the Powerwall 3 product label on the left side of the unit, use a paint pen, permanent marker, or similar to mark the configured power / current output (see [Install Powerwall and Generation Breakers in the Backup Gateway on page 52](#) for breaker size options).

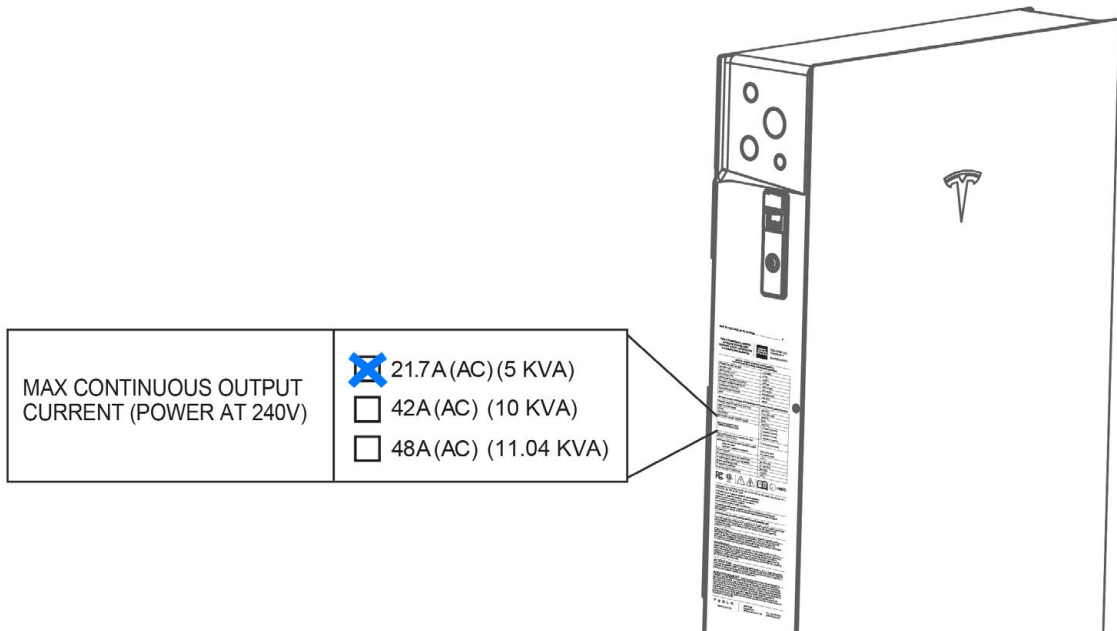



STEP 8: INSTALL CLAMP-ON FERRITE CORES

Powerwall 3 ships with (6) clamp-on ferrite cores for AC wiring and the Powerwall Protective Earth. Additional ferrite cores are factory-installed for the PV wiring and the Tesla Asset Controller (TACO) low voltage harness.

CAUTION: Ferrite cores are fragile; handle with caution.

NOTE: All ferrite cores provided with Powerwall 3 are split core; they can be opened to be placed around the conductor(s) rather than threading them over the conductor(s).

NOTE: Equipment grounding conductors do not need to be included in ferrite cores.

1. Install the **small square** clamp-on ferrite core around the TACO factory-installed harness.

NOTE: If the ferrite core has already been installed by the factory, skip this step. If the accessory bag contains an additional small square ferrite core when there is already one installed on the harness, the extra ferrite core can be recycled or saved as a spare.

2. Install (1) of the **medium** clamp-on ferrite cores around L1 and N. Ensure the ferrite core is as close to the AC connector as possible without bending or deforming the wires.
3. Install (1) of the **medium** clamp-on ferrite cores around L1, N, and the Protective Earth.
4. Install the (1) **small** clamp-on ferrite core around the Protective Earth.
5. Install the (2) **marked (with pink sticker) medium** clamp-on ferrite cores around L1 and N in the top of the wiring compartment.
6. Secure all ferrite cores closed with the provided cable ties.

Figure 18. Ferrite Core Around AC Conductors and Protective Earth

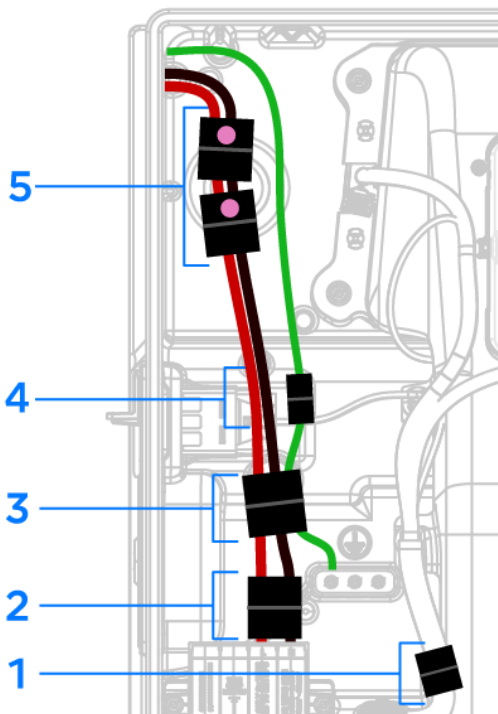



STEP 8: INSTALL CLAMP-ON FERRITE CORES

 **NOTE:** Ensure the ferrite cores are installed as described here; for instance, do not clamp a ferrite core around only L1 or N when it is required to be clamped around both L1 and N:

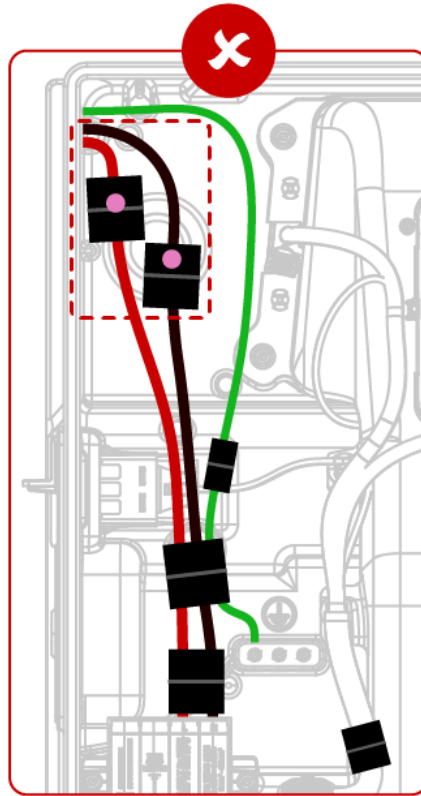
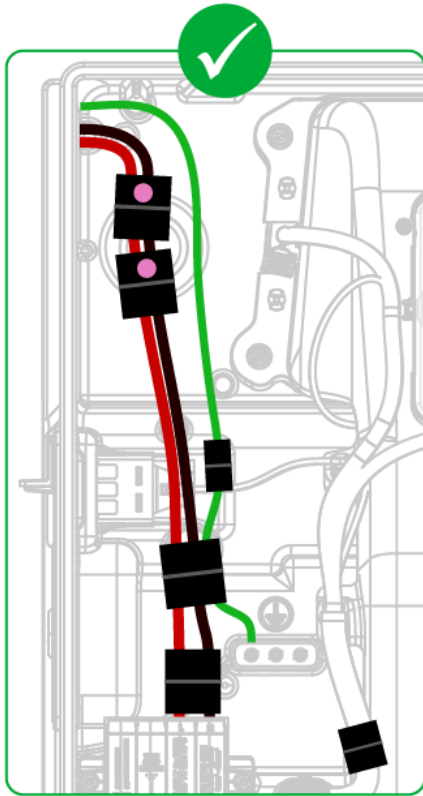



STEP 9: INSTALL ENERGY METERING FOR THE SYSTEM

Visibility on power and energy data is needed for the Powerwall 3 system to operate properly. An energy meter accomplishes this by measuring voltage (by voltage tap) and current (by Current Transformer, CT) at certain points in the system.

There are many possible configurations for installing metering depending on system design. However, there are two goals:

- **Metering the Site** – Site meters show the overall power flow to/from a site from the Grid's perspective. Thus, Site meter(s) must be installed upstream of all solar production, Powerwalls, and loads.
- **Metering Solar** – Solar meters capture production from PV inverter(s). There must not be any loads or Powerwalls behind the Solar CTs. This would result in under- or over-estimation of solar production. In this system, Powerwall 3 performs its own Solar metering. Standalone (AC-coupled) solar inverters must be metered by Backup Gateway 2 Meter Y.

Figure 19. Example Whole Home Backup Metering Diagram

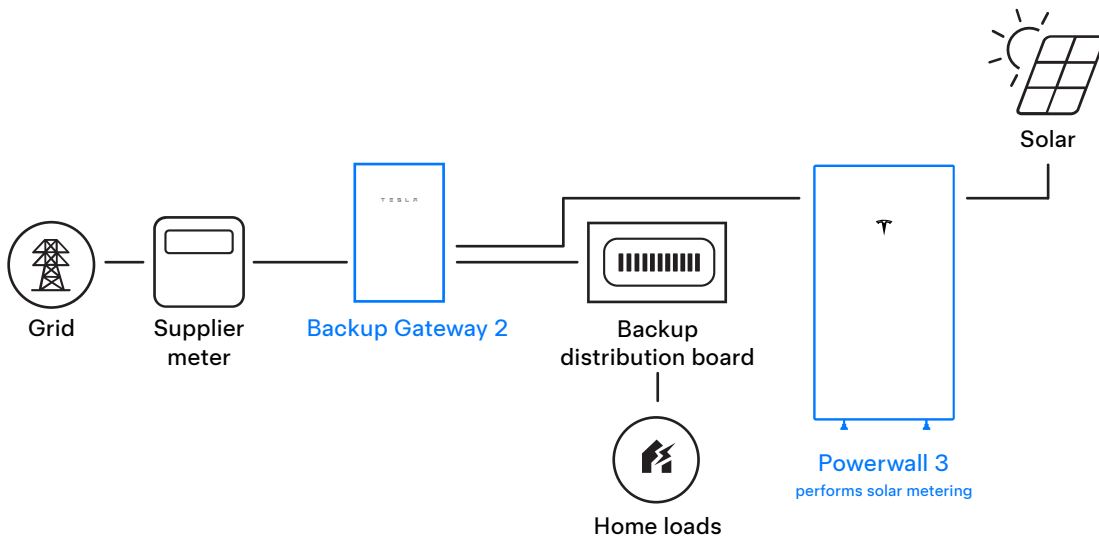



STEP 9: INSTALL ENERGY METERING FOR THE SYSTEM

Figure 20. Example Partial Home Backup Metering Diagram: Non-Backup Distribution Board Connected to Non-Backup Lugs

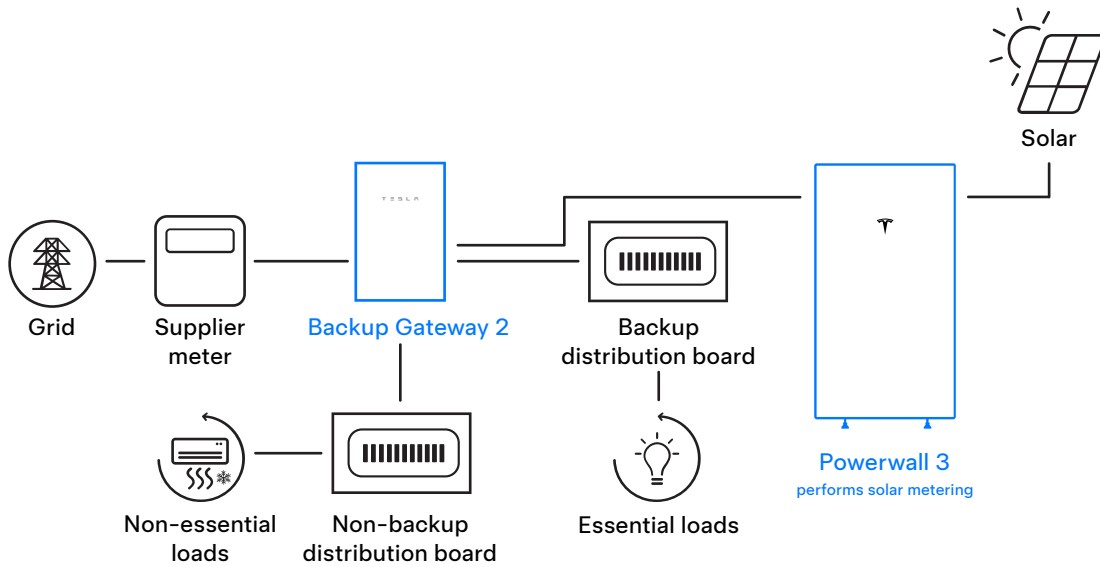

NOTE: See [Conductor Connections for Single Phase \(left\) and Three-Phase \(right\) on page 51](#) for the location of the Non-Backup lugs.

Figure 21. Example Partial Home Backup Metering Diagram: Meter Y Measures Upstream Non-Backup Loads

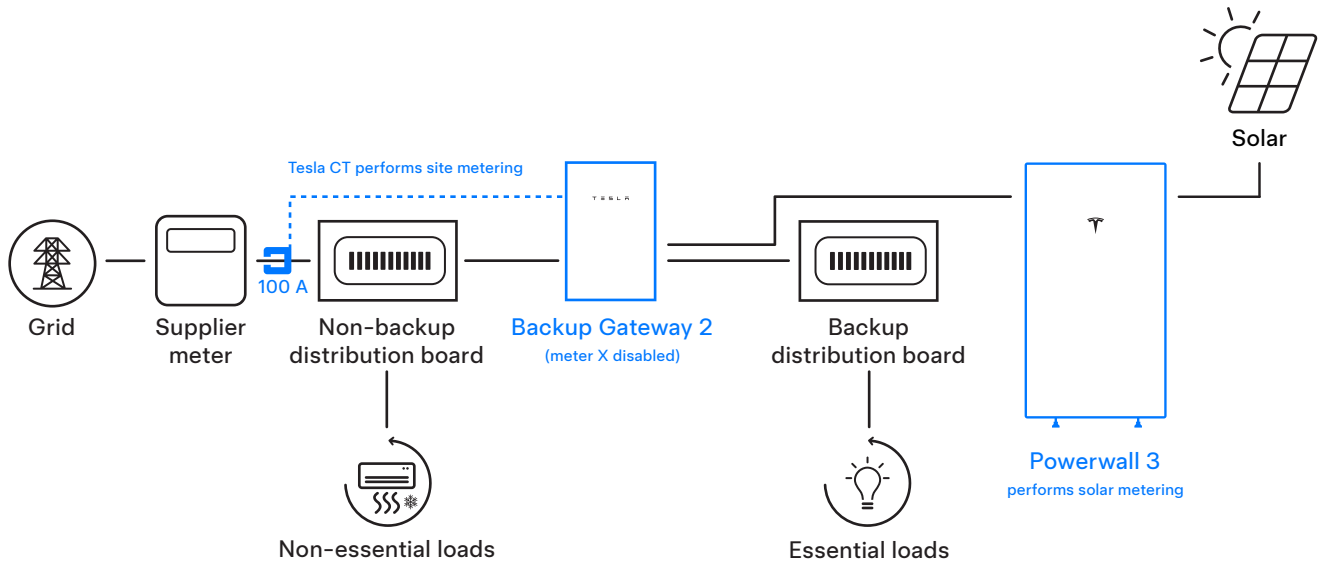

Site Metering for Backup Gateway 2

Backup Gateway 2 makes metering simple with built-in options for Site metering:

- **Internal Primary Meter (Meter X)** – This Site meter may be used when the Grid connection is at the *Supply* terminals. No additional steps are needed during install.
- **Internal Auxiliary Meter (Meter Y)** – If there are any loads or solar upstream of the *Supply* terminals, or if the system includes standalone (AC-coupled) solar, Tesla 100 A CTs connected to the Internal Auxiliary Meter can be used to measure loads / solar less than 100 A. One Tesla 100 A CT is included in the Accessory Kit, and additional CTs (Tesla P/N 1467316-00-x) may be ordered individually.



STEP 9: INSTALL ENERGY METERING FOR THE SYSTEM

The Tesla 100 A CTs may be extended a max distance of 330 ft (100 m) by splicing twisted pair or using the Tesla 100A CT Extension (10 ft/3 m) (Tesla P/N 1467274-00-x). Use minimum 600V 0.5 mm² conductors or larger to extend CTs up to 330 ft (100 m). Voltage rating of the extension wire must be equal to or greater than all other adjacent circuits.

Solar Metering for Standalone Solar

Solar must be monitored using Backup Gateway Meter Y and Tesla 100 A CTs. The CT is connected to the Backup Gateway Internal Auxiliary Meter (Meter Y). Meter Y has three (3) CT ports, and one Tesla 100 A CT is included in the Backup Gateway accessory kit. Additional Tesla 100 A CTs (Tesla P/N 1467316-00-x) may be ordered individually. See [Install Tesla 100 A CTs on page 66](#) for instructions.

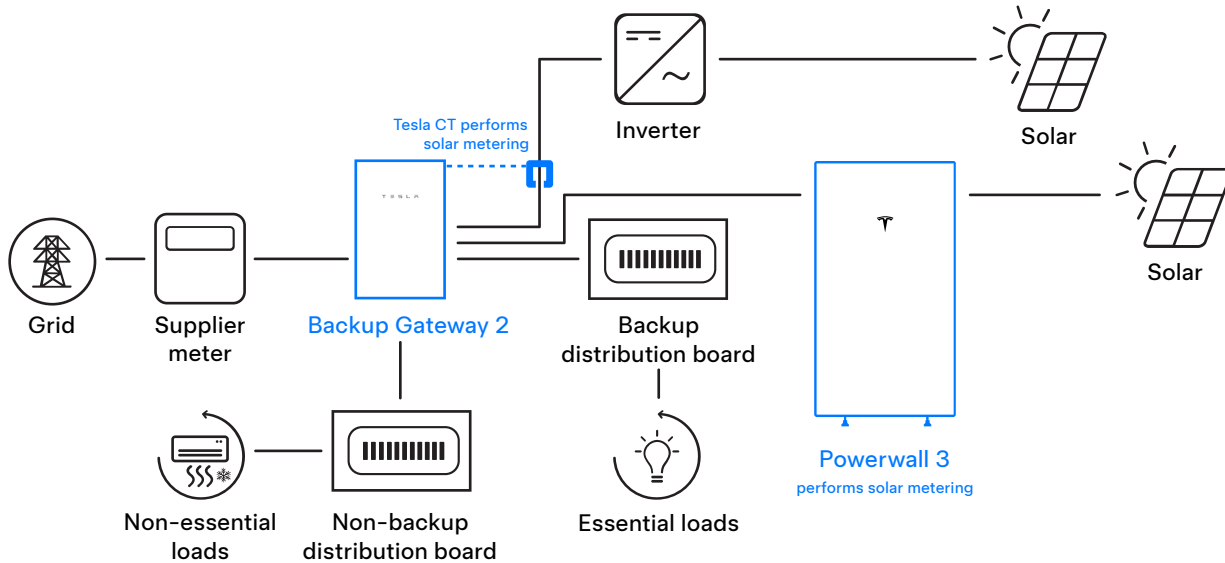



STEP 9: INSTALL ENERGY METERING FOR THE SYSTEM

Install Tesla 100 A CTs

WARNING: Before installing, disconnecting, and/or adjusting CTs, ensure the circuits being measured are not energized and the system is completely powered down. Failure to de-energize the system may compromise operator and equipment safety.

1. Plug the Tesla 100 A CT into the terminal in the Backup Gateway. Ensure the connector is fully seated in the terminal.
2. Clamp the CT around the conductor to be measured.

Figure 22. Embedded Site CTs and Solar CT Connectors

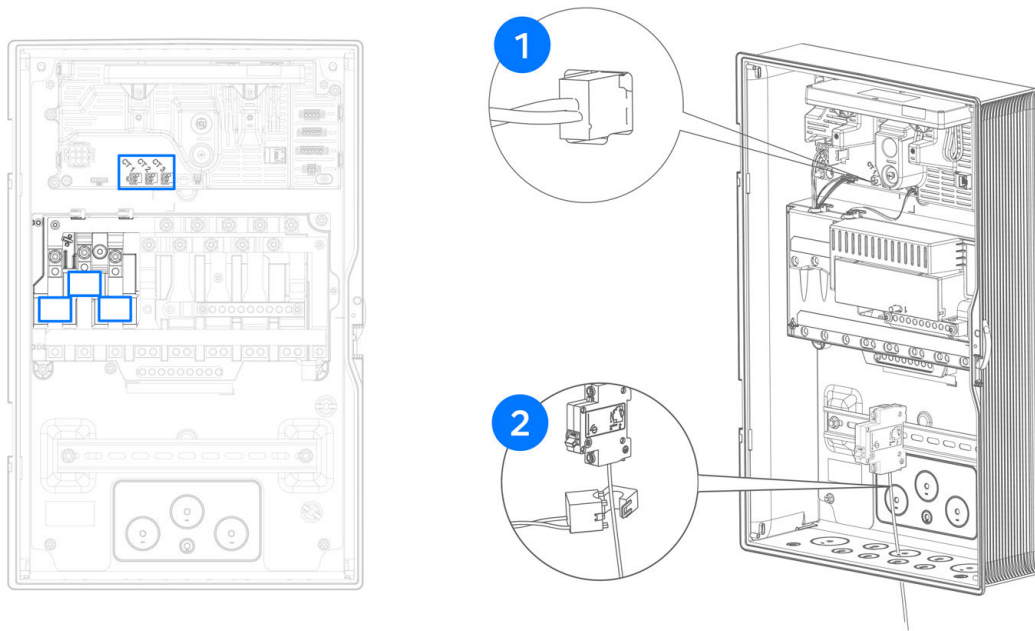

Tips

- When metering 3-phase solar inverters, install CTs on L1, L2, and L3 output of the solar inverter AC circuit.



NOTE: A single CT can be installed on L1 and connected to CT1 port to measure the solar power from a 3-phase solar inverter. Make sure to toggle **1CTx3** button to the ON position when configuring the CT during commissioning; the software triples the power measured by the CT. To ensure that the total power output calculated by software is correct, the solar power must be converted by a balanced 3-phase solar inverter, which distributes power evenly between the three phases.

- Ensure CTs are facing the proper direction as indicated on the label. A CT will show negative current if installed backwards.



STEP 10: COMPLETE THE INSTALLATION

Plan Internet Connection for Powerwall

Internet connectivity is required to receive the full 10-year Powerwall warranty, and for the customer to see their system in the Tesla App.

Cellular is available for commissioning and as a backup connection when Wi-Fi or Ethernet connections are lost. Once Powerwall has been registered to the customer, they can configure a Wi-Fi connection using the Tesla app. For customers without a strong Wi-Fi connection, install an Ethernet connection as follows.



NOTE: If the customer Wi-Fi network is available during the installation, the Wi-Fi connection can be configured during Device Setup.

Install Ethernet Connection

- Ethernet cable must be CAT5 cable at minimum.
- If not possible to run an Ethernet cable directly to the customer's network router, Powerline Ethernet socket adapters may be used.



NOTE: If installing Powerline Ethernet socket adapters, ensure they are installed in the backup circuit.

- Connect the Ethernet cable to one of the RJ45 Ethernet terminals in the Powerwall 3. The LED on the Ethernet terminal will illuminate green to indicate Ethernet is connected.



NOTE: The amber LED on the Ethernet terminal will not illuminate. This is expected behavior.

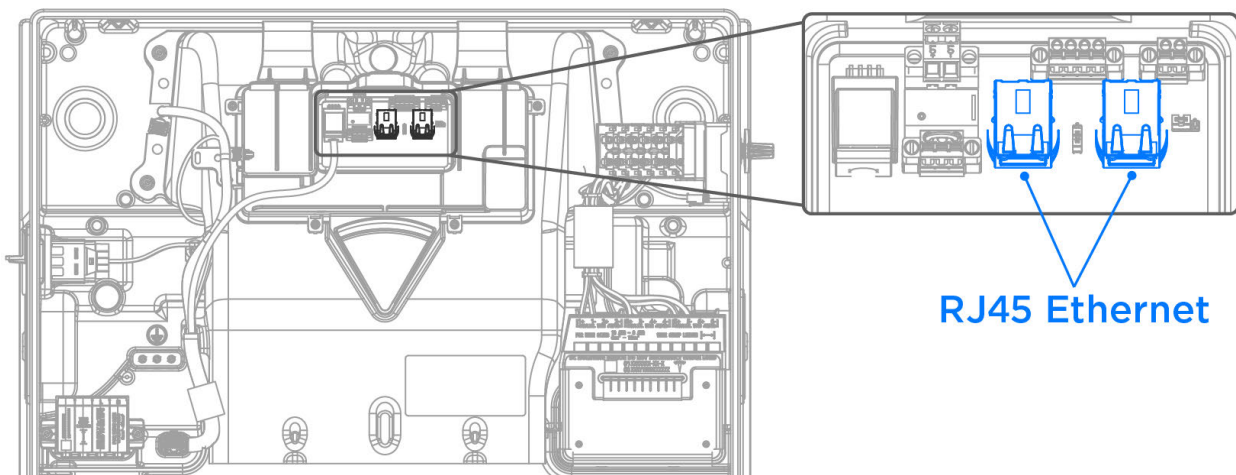

NOTE: See [Prepare Ethernet Wiring with RJ45 Connectors on page 88](#) for instructions to crimp RJ45 connectors on CAT5 or CAT6 cable.



STEP 10: COMPLETE THE INSTALLATION



NOTE: Only connect Ethernet wiring to the Powerwall 3 Ethernet ports. The Tesla Asset Controller in Powerwall 3 controls system operation, so these Ethernet ports are the only functional ports in the system. **Do not** connect Ethernet to the Backup Gateway Ethernet port.

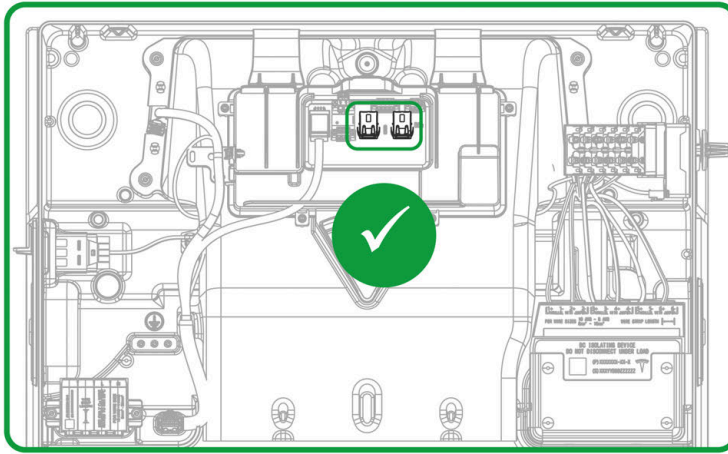

Powerwall 3

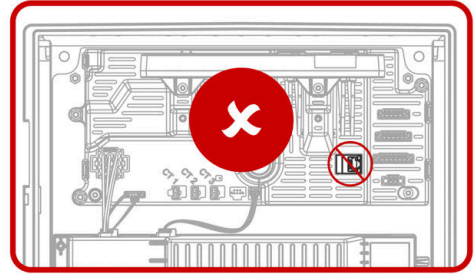

Backup Gateway

Close Backup Gateway 2 Wiring Compartment

1. **Before closing any installed hardware**, take photos of the completed wiring in the Powerwall, Backup Gateway 2, and main distribution board.
2. Inspect the AC and PV wiring terminals to ensure all wire strands are properly inserted.
3. Ensure that all conduit junctions and cable entry points are secure and properly sealed.
4. Install the Backup Gateway deadfront panel and secure it firmly with the original screw. Mount the Backup Gateway door, and latch it shut.

Figure 23. Install the Backup Gateway Deadfront Cover and Glass Door

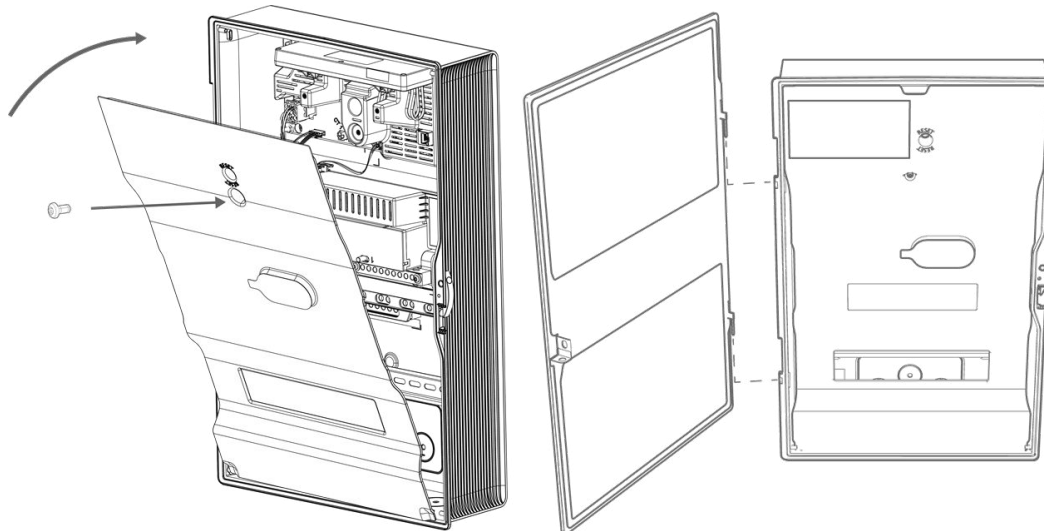

NOTE: If the Backup Gateway is installed outdoors or in a high-traffic area, the latch can be locked shut.





5. Clearly label all circuit breakers.

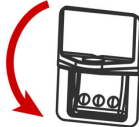
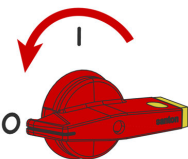

STEP 11: TURN ON AND COMMISSION THE SYSTEM

WARNING: Before terminating any conductors inside Powerwall 3, ensure that the integrated DC isolator and Powerwall 3 On/Off switch are both turned OFF to de-energize the system. Confirm lack of voltage at the AC and PV terminals before proceeding.

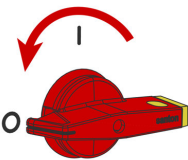
Prepare the System for Commissioning

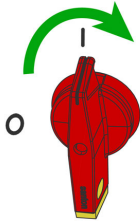
Powerwall Installation Complete?	Solar Installed?	Powerwall 3 On / Off Switch	Integrated DC Isolator	Powerwall 3 Breaker	Commissioning
No (no AC service, install crew unable to complete, etc.)	No	Leave the Powerwall 3 switch OFF 	Leave the integrated DC isolator OFF 	Leave the Powerwall 3 breaker CLOSED (ON)	Commissioning cannot be completed at this time
Yes	No	Leave the Powerwall 3 switch ON 	Leave the integrated DC isolator OFF 	Leave the Powerwall 3 breaker CLOSED (ON)	See Commission the System Ahead of Solar Installation on page 70 WARNING: Turn the Powerwall 3 switch OFF to de-energize the system terminating any conductors inside Powerwall 3. Confirm lack of voltage at the AC and PV terminals before proceeding.
Yes	Yes	Leave the Powerwall 3 switch ON 	Leave the integrated DC isolator ON 	Leave the Powerwall 3 breaker CLOSED (ON)	See Commission the System After Powerwall and Solar Installation on page 74



STEP 11: TURN ON AND COMMISSION THE SYSTEM

Commission the System Ahead of Solar Installation

Powerwall Installation Crew Instructions

1. Close the AC circuit breaker for Powerwall 3 and the Backup Gateway.
2. Turn the Powerwall 3 switch **ON**.
3. Launch the **Tesla One** app.



NOTE: Ensure Tesla One is updated to version 7.9.1 or greater, or [install Tesla One](#) if using for the first time.

4. Navigate to **Device Setup** to begin commissioning.
5. Select **Scan** and scan the Powerwall 3 QR label to connect to the TeslaPW Wi-Fi network.



NOTE: Connect to Powerwall 3 to commission the system. **Do not attempt to connect to Backup Gateway to commission.**

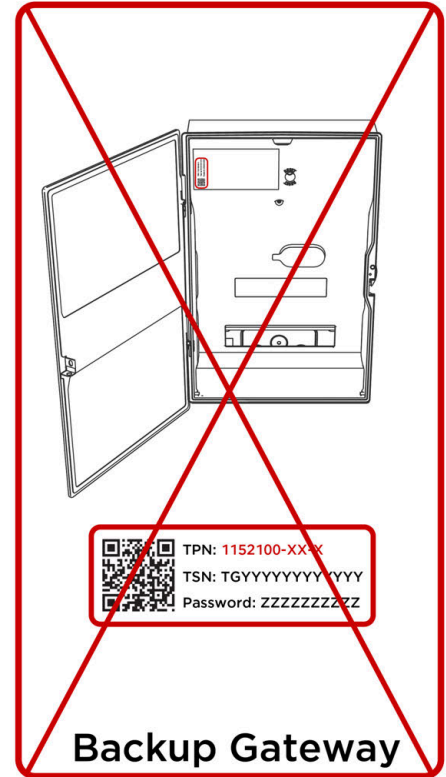
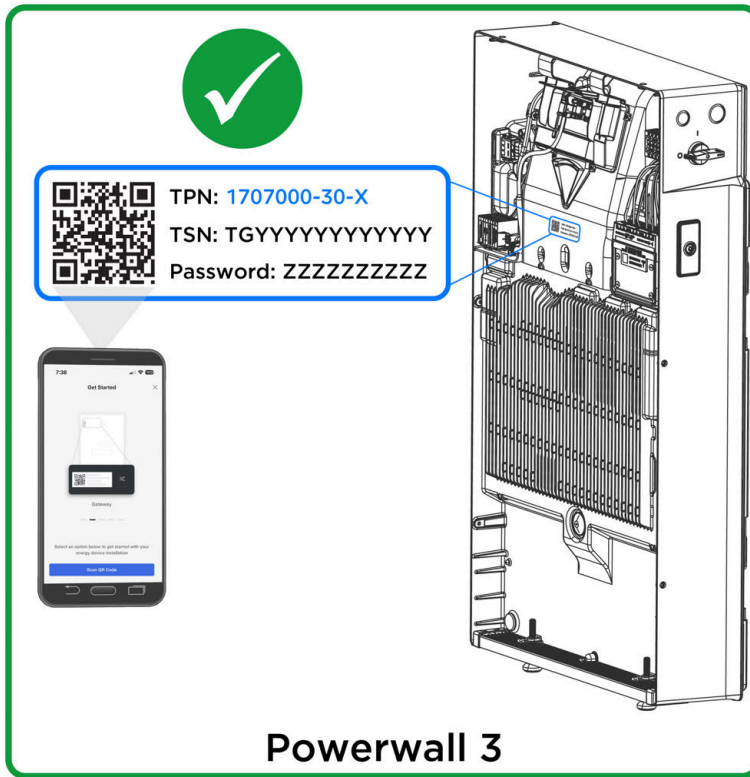

6. Address any alerts to complete commissioning, skipping PV commissioning steps.





NOTE: When commissioning a system with no solar, Powerwall will charge from grid until State of Energy (SOE) is 20%. This is expected behavior.

7. Perform the Backup Test, selecting **Solar is not expected**.

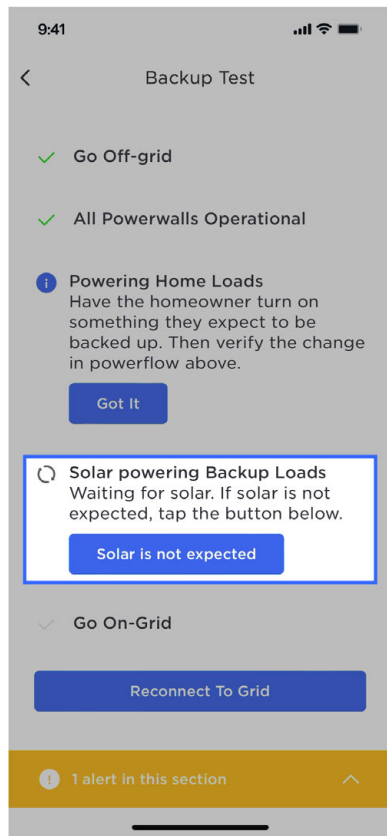

STEP 11: TURN ON AND COMMISSION THE SYSTEM



 **NOTE:** The Backup Test can be performed during the Backup Gateway 2 device update. There is no need to wait for the update to complete before performing the Backup Test.

8. Leave the system running in Tesla One.
9. Leave the Powerwall 3 switch **ON** and the breaker **CLOSED** to enable charging.
10. Leave the Powerwall 3 integrated DC isolator **OFF**.
11. Leave the following accessories with the customer, for use by the Solar installation crew:
 - Extra T20 fasteners for front cover
 - Installation quick guide (for guidance on correctly installing PV wiring)

Solar Installation Crew Instructions

1. Retrieve the Powerwall 3 accessories from the customer. These should have been left by the Powerwall crew.
2. Turn the Powerwall 3 switch OFF to de-energize the system; see [Appendix G: Shutting Down Powerwall 3 on page 110](#) for complete de-energization instructions.

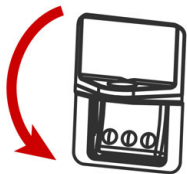

3. Confirm the Powerwall 3 integrated DC isolator is OFF.



STEP 11: TURN ON AND COMMISSION THE SYSTEM

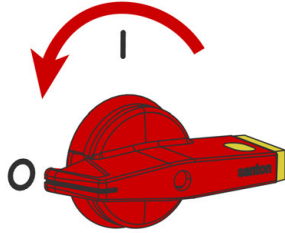

WARNING: Confirm lack of voltage at the AC and PV terminals before proceeding.

4. See [STEP 4: Make Solar PV Connections on page 43](#) for instructions to complete the solar installation.
5. Re-energize Powerwall 3:
 - a. Remove the lock / tag and breaker hasp from the Powerwall 3 breaker, then turn the breaker ON.
 - b. Turn the Powerwall 3 switch ON.

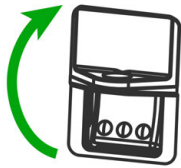

6. Turn the Powerwall 3 integrated DC isolator **ON**.

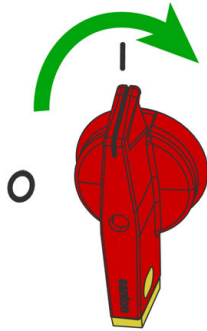

7. Launch the **Tesla One** app.



NOTE: Ensure Tesla One is updated to version 7.9.1 or greater, or [install Tesla One](#) if using for the first time.

8. Navigate to **Device Setup** to begin commissioning.
9. Select **Scan** and scan the Powerwall 3 QR label to connect to the TeslaPW Wi-Fi network.



STEP 11: TURN ON AND COMMISSION THE SYSTEM



NOTE: Connect to Powerwall 3 to commission the system. **Do not attempt to connect to Backup Gateway to commission.**

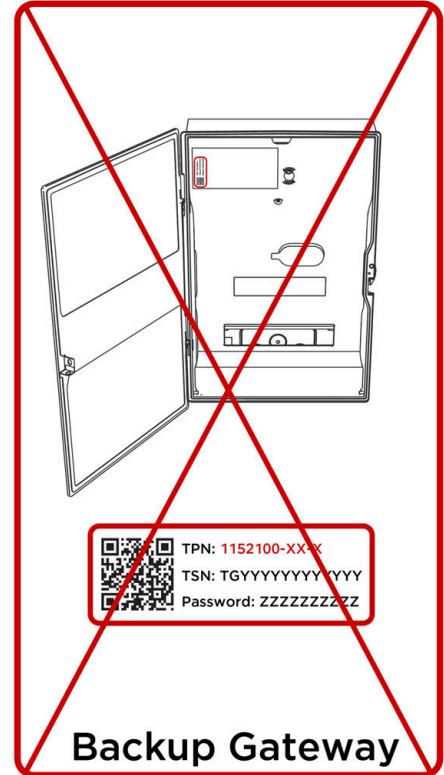
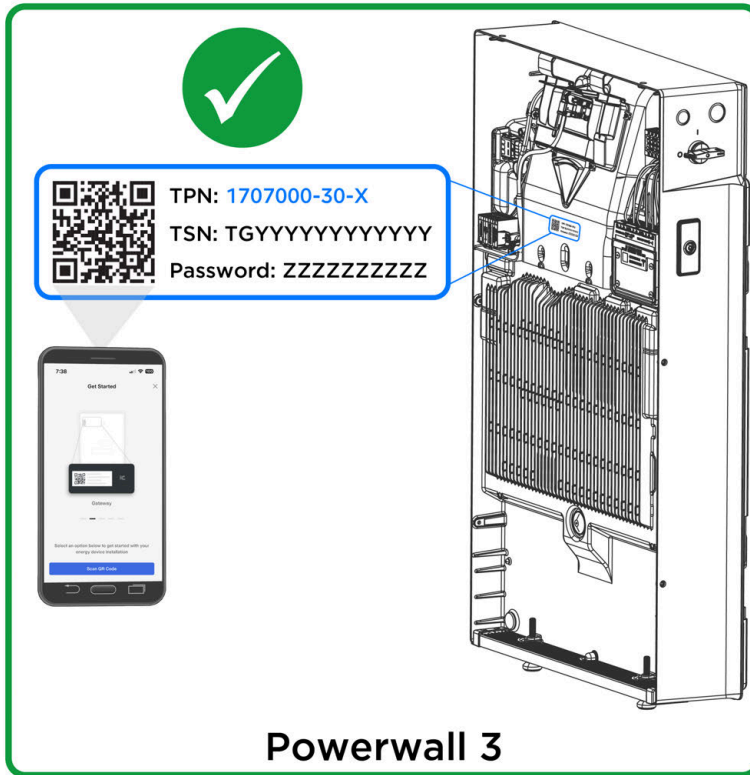

10. Address any alerts to complete commissioning.
11. On the Powerwall 3 *Device* page, compare the MPPT voltages with those listed on the planset to confirm the installation matches what is expected for the strings.
12. Perform the Backup Test with solar.
13. Install the Powerwall 3 front cover, fastening with the new T20 fasteners that were left with the customer.
14. Leave the system running in Tesla One.
15. Leave the Powerwall switch **ON** and the breaker **CLOSED** to enable charging.



NOTE: See the [Powerwall 3 Device Setup Guide](#) for instructions.



NOTE: The Powerwall 3 On / Off switch has a locking mechanism. When the switch is locked it cannot be turned on. See [Powerwall 3 Switch Locking Mechanisms on page 100](#) for more information.



STEP 11: TURN ON AND COMMISSION THE SYSTEM

Commission the System After Powerwall 3 and Solar Installation

1. Close the AC circuit breaker for Powerwall 3 and the Backup Gateway.
2. Turn the Powerwall 3 switch **ON**.

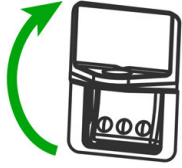

3. Turn the Powerwall 3 Integrated DC Isolator **ON**.

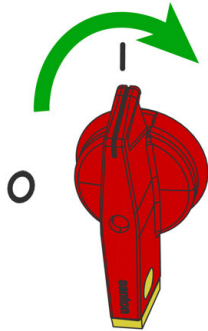

4. Launch the **Tesla One** app.



NOTE: Ensure Tesla One is updated to version 7.9.1 or greater, or [install Tesla One](#) if using for the first time.

5. Navigate to **Device Setup** to begin commissioning.
6. Select **Scan** and scan the Powerwall 3 QR label to connect to the TeslaPW Wi-Fi network.



STEP 11: TURN ON AND COMMISSION THE SYSTEM



NOTE: Connect to Powerwall 3 to commission the system. **Do not attempt to connect to Backup Gateway to commission.**

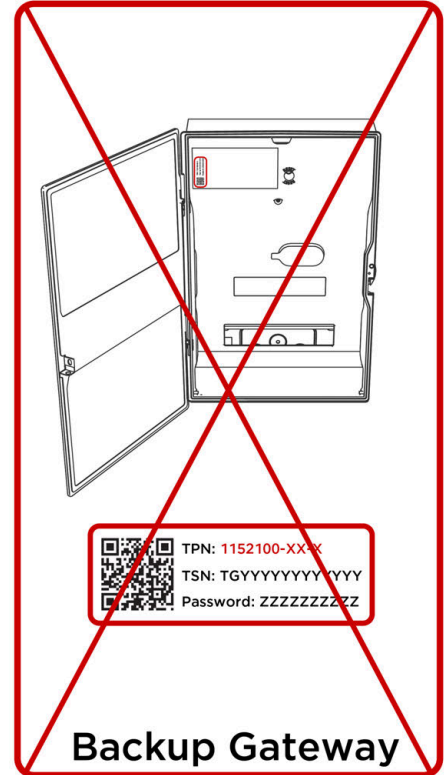
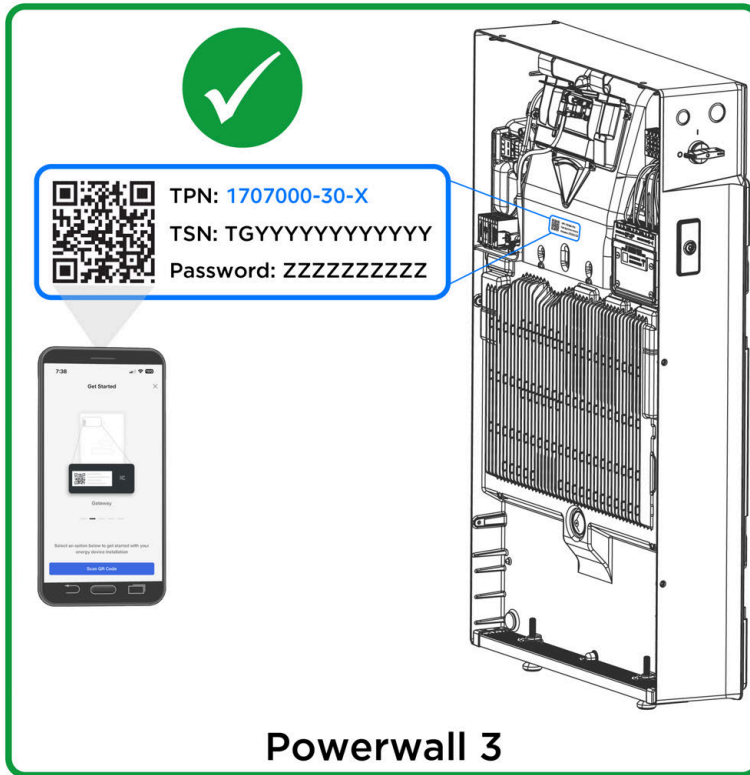

7. Address any alerts to complete commissioning.



NOTE:

- See the [Powerwall 3 Device Setup Guide](#) for instructions.
- The Backup Test can be performed during the Backup Gateway 2 device update. There is no need to wait for the update to complete before performing the Backup Test.

8. Leave the system running in Tesla One.

9. Leave the Powerwall switch **ON** and the breaker **CLOSED** to enable charging.



NOTE: The Powerwall 3 On / Off switch has a locking mechanism. When the switch is locked it cannot be turned on. See [Powerwall 3 Switch Locking Mechanisms on page 100](#) for more information.



STEP 12: INSTALL POWERWALL 3 FRONT COVER

1. Inspect the AC and PV wiring terminals to ensure all wire strands are properly inserted.
2. Ensure that all conduit junctions and cable entry points are secure and properly sealed.
3. Arrange all communication wires inside the Tesla Asset Controller cover, then close the cover.

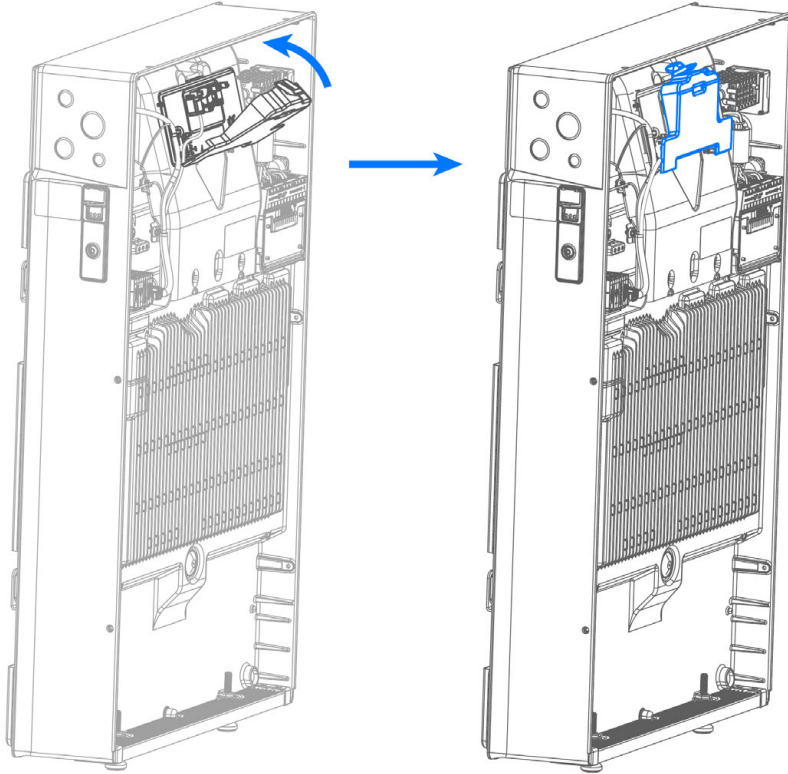

4. Arrange all wires neatly inside the Powerwall wiring compartment.



STEP 12: INSTALL POWERWALL 3 FRONT COVER

5. Install the air intake screen over the opening at the bottom of Powerwall, ensuring it snaps into place.

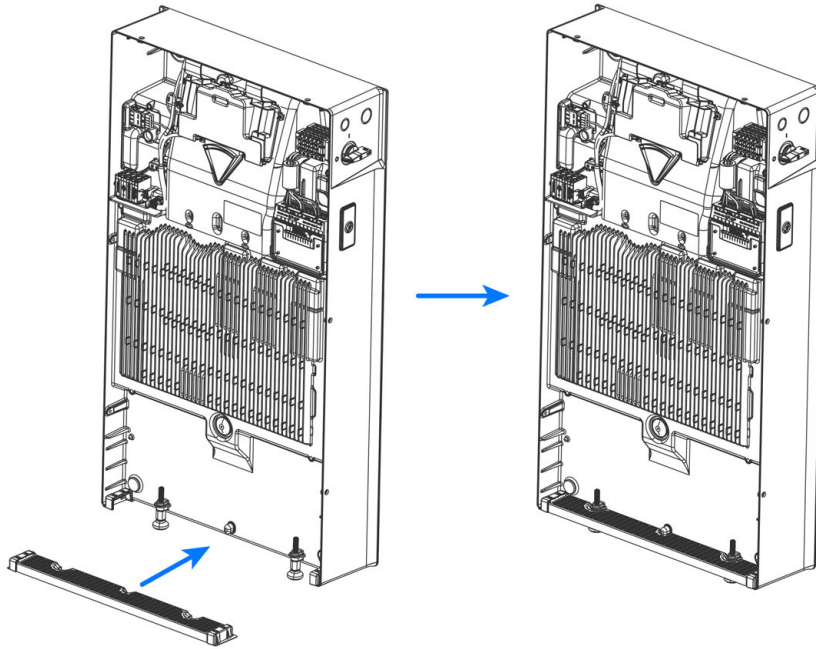

6. Clean the front edge of the Powerwall enclosure with a microfiber cloth to remove any debris that might interfere with the seal.
7. Carefully remove the glass front cover from its packaging and, using a microfiber cloth, clean the sealing gasket around the edge of the front cover to remove any debris that might interfere with the seal.



CAUTION: Take extreme care when handling the sealing gasket. Damage to or contamination of the gasket or its mating surface could compromise Powerwall's ingress protection, resulting in product damage.

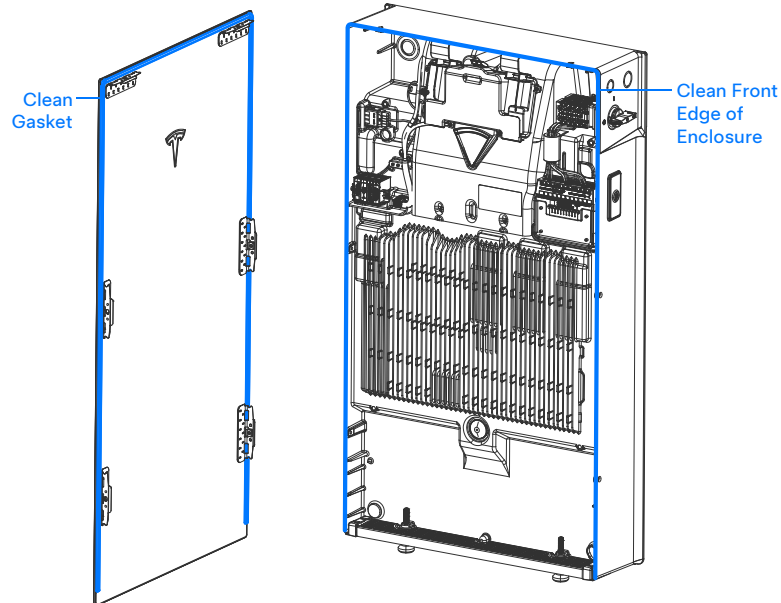

8. Carefully install the glass front cover:
 - a. Align the lower mounting tabs with the two alignment shelves in the enclosure (A).



STEP 12: INSTALL POWERWALL 3 FRONT COVER

- b. Rotate the front cover toward the enclosure to engage the top mounting tabs with the enclosure (B). Maintain pressure (approximately 2 Nm) on the front of the cover to compress the sealing gasket.

CAUTION: Maintain pressure to keep the sealing gasket compressed until all fasteners are installed and tightened. If the sealing gasket is not compressed, the fasteners may thread form in the enclosure, breaking the front cover mounting tabs.

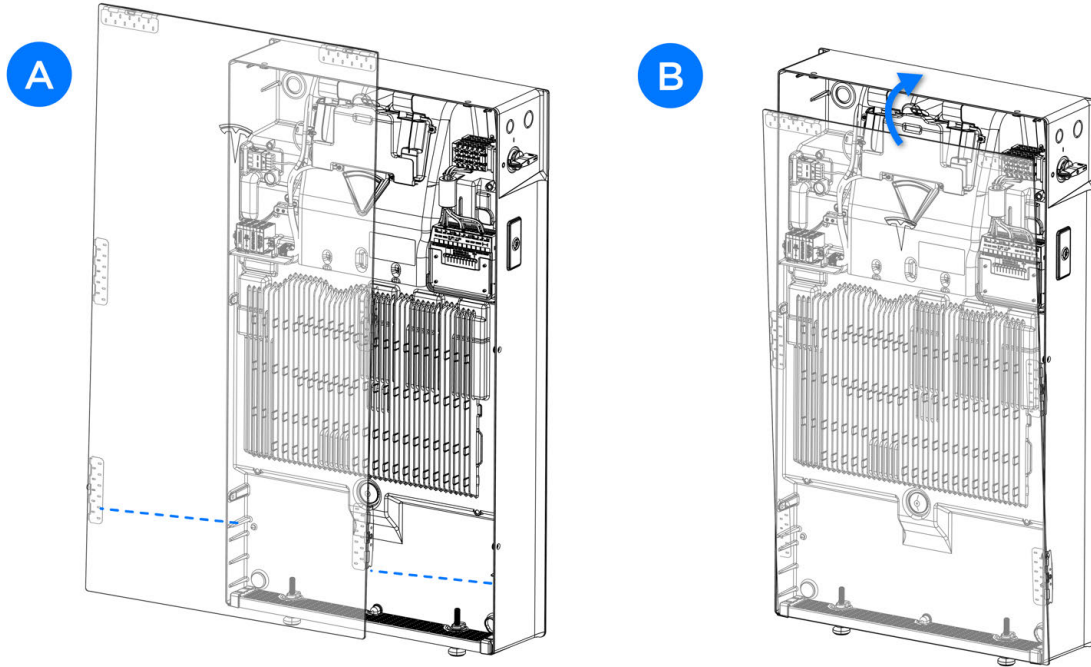



STEP 12: INSTALL POWERWALL 3 FRONT COVER

c. Install and tighten the top (2X) T20 fasteners in the fastener slots (**C**).



NOTE: T20 fasteners (Tesla P/N 1847553-00-A) are included in the accessory bag:

- Early revisions of the fasteners (left, below) are single use; to reuse these fasteners, remove the black gasket from the fastener
- Later revisions of the fasteners (right, below) do not include a gasket and can be reused without any alteration



The gasket is not required and does not impact the enclosure rating of Powerwall 3.

d. Install and tighten the remaining (4X) T20 fasteners in the fastener slots on the sides of the unit (**D**).

e. Tighten each fastener to approximately (2.8 Nm) or hand-tight.



CAUTION: Do not use an impact driver to torque the fasteners.



STEP 12: INSTALL POWERWALL 3 FRONT COVER

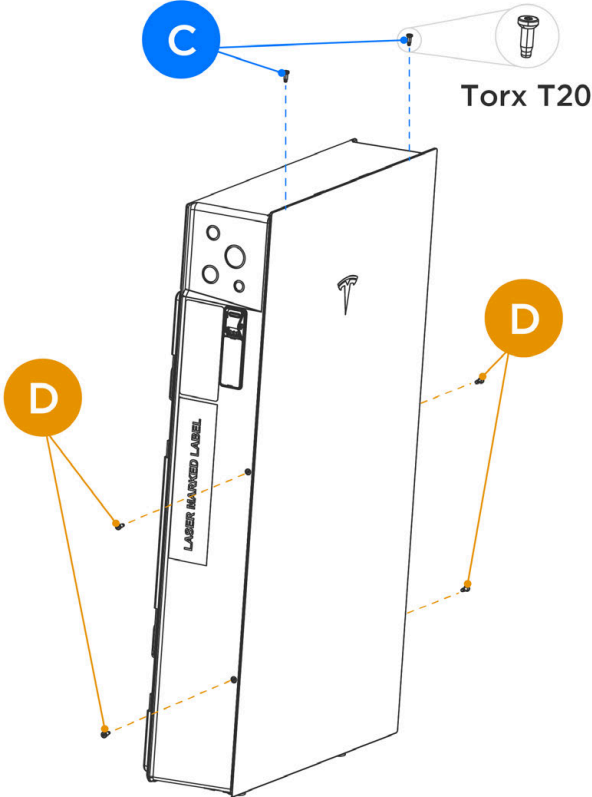



STEP 13: DEMONSTRATE THE INSTALLATION

1. Ask the homeowner to download and install the Tesla mobile app, log in or create a new Tesla account, and assist them with registering their product.
2. Show the homeowner the location of the serial number sticker on the left side of Powerwall, below the On/Off switch.
3. Demonstrate the capabilities of the Tesla mobile app, such as how to change the operation mode.
4. Simulate an outage by opening the main breaker and show that Powerwall is powering backup loads.
5. Archive the photos from the installation.

Technical Support

Resources for Certified Installers, including the latest versions of installation manuals, are available within the Tesla Partner Portal:

<https://partners.tesla.com>

Maintenance

Powerwall 3 does not require pre-scheduled preventative maintenance. The only maintenance required by an owner is to keep the unit connected to the internet and free and clear of debris, especially around the air intake and exhaust. When needed, the air intake vent can be removed and hosed off.

To clean Powerwall 3, use a soft, lint-free cloth. If needed, the cloth can be dampened with mild soap and water only. Do not use cleaning solvents to clean Powerwall 3, or expose Powerwall 3 to flammable or harsh chemicals or vapors.



APPENDIX A: POWERWALL 3 ANCHORING DETAILS

General Anchoring Notes



NOTE: The details below are minimum guidelines and are not guaranteed to be applicable.



NOTE: All fasteners shall be galvanized or stainless steel for exterior applications.



NOTE: All wall framing referenced in the details must be part of the home's main permitted bearing wall and/or lateral force resisting system. The contractor and their licensed design professional are responsible for ensuring the walls, and their load transfer connections, are structurally sound to support all code-specified vertical and lateral loading imposed by the equipment. Improper mounting or the use of a wall that is not structurally sound could result in serious injury and/or product damage.



NOTE: At the contractor's expense and with no liability to Tesla, the homeowner and contractor can work with a third party licensed engineer and building department to develop alternative supports.



NOTE: Do not mount below or above windows of the same story wall. Mounting equipment on fences, half walls, retaining walls, or other non-structural construction is not allowed. Supporting framing must be part of a permitted structure and any unusual framing near the mounting area that may compromise the wall's integrity shall be evaluated by the contractor and their licensed design professional.

Anchoring Details for Ground- or Wall-mounting Powerwall 3 with Wall Bracket on Existing Approved Foundation

Reference these anchoring details when mounting Powerwall 3 to the provided mounting bracket.

Concrete Masonry Unit Wall

Minimum strength must be 11 MPa.

Use at least four (one in each corner, in any available anchor slot) 10 mm concrete anchors of sufficient length for 50 mm embedment into the material.

Anchors shall not be installed within 305 mm of wall edges or 38 mm of masonry block edges.

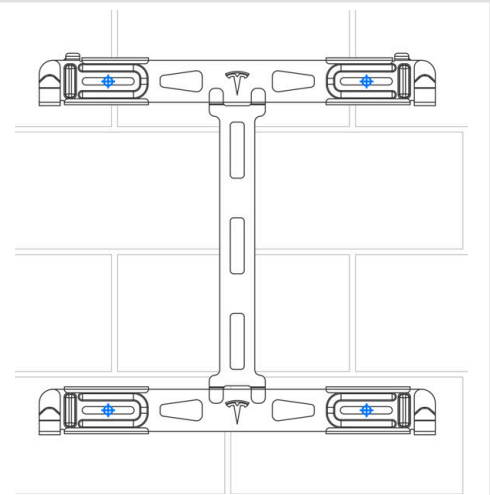



APPENDIX A: POWERWALL 3 ANCHORING DETAILS

Solid Concrete Wall

Minimum strength must be 18 MPa.

Use at least four (one in each corner, in any available anchor slot) 10 mm concrete anchors of sufficient length for at least 64 mm embedment into the wall.

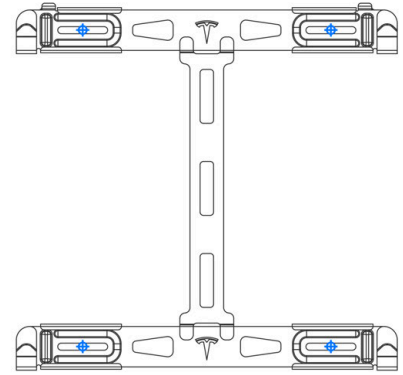

Brick Wall

(Double and Single Layer of Brick Masonry)

Minimum strength must be 12 MPa.

Use at least four (one in each corner, in any available anchor slot) 6 mm masonry anchors of sufficient length for 79 mm embedment.

 **NOTE:** Faux brick veneer is not a supported wall type for Powerwall installations.

 **NOTE:** Fasteners shall not be installed in mortar joints.

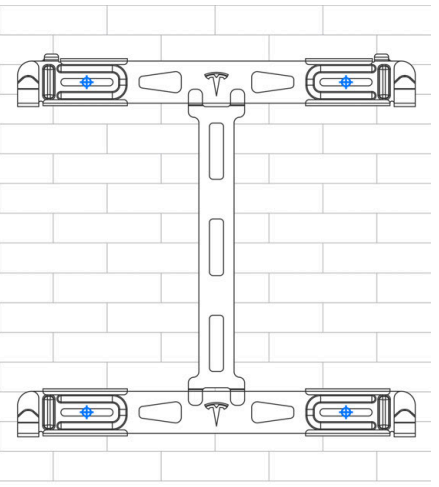

Channel Strut (Unistrut)

Struts must be minimum 12 gauge, and either 22 mm or 41 mm.

If mounting on wood structural members, attach each strut to at least two structural members, using at least one 6 mm wood screw with washer per structural member, of sufficient length for at least 64 mm embedment into the structural members.

If mounting on metal structural members, attach each strut to at least three structural members, using at least one #14 (6 mm) sheet metal screw with washer per structural member, of sufficient length to penetrate at least 3 threads beyond the structural members.

 **NOTE:** For either wood or metal structural members, these requirements are per Powerwall (e.g. two structural members per Powerwall on wood structural members, or three structural members per Powerwall on metal structural members).

To attach the bracket to the struts, use at least four (one in each corner) 10 mm hex head screws with washers and strut nuts.

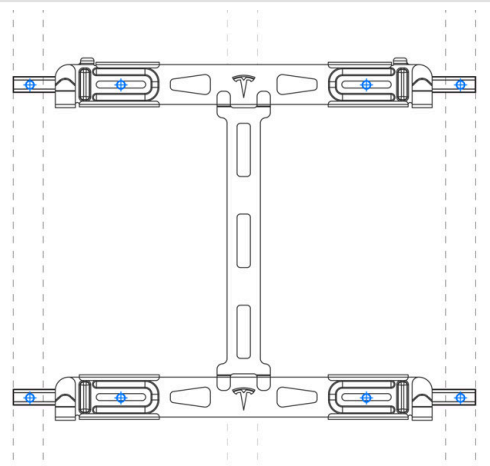



APPENDIX A: POWERWALL 3 ANCHORING DETAILS

Channel strut shall have a maximum unsupported span of 610 mm and shall not be cantilevered.

Wood Structural Members 305 mm to 432 mm

If anchoring directly into wood structural members, use at least four (one in each corner) 6 mm wood screws with washers, of sufficient length for at least 64 mm embedment into the structural members.



NOTE: See [Channel Strut \(Unistrut\) on page 83](#) for structural member spacing greater than 432 mm, up to 610 mm.

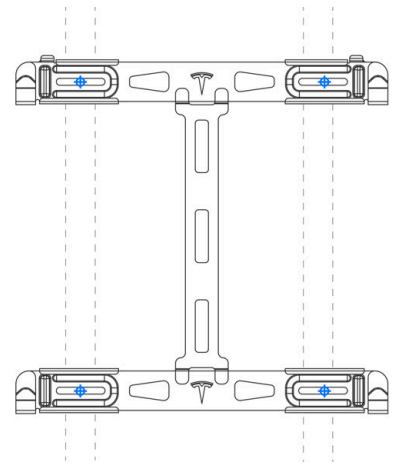

Wood Structural Members 305 mm to 432 mm

If anchoring to blocking between wood structural members, use minimum 38 x 89 mm blocks, end-nailed into structural members with two 16d (89 x 4 mm) nails or toe-nailed into structural members with four 8d (64 x 3 mm) nails. Use at least four (one in each corner) 6 mm wood screws with washers, of sufficient length for at least 64 mm embedment into the blocking.



NOTE: See [Channel Strut \(Unistrut\) on page 83](#) for structural member spacing greater than 432 mm, up to 610 mm.

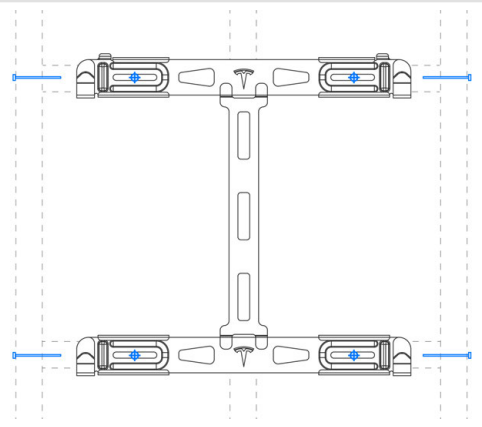

Metal Structural Members 305 mm to 432 mm

If anchoring directly to metal structural members, structural members must be minimum 18 gauge. Use at least four (one in each corner) #14 (6 mm) sheet metal screws with washers, of sufficient length to penetrate at least 3 threads beyond the structural member.

If backing is needed between the structural members, the backing must be minimum 18 gauge. Attach backing to metal structural members with 12 gauge 76 x 76 mm angle clip or Simpson SFC2.25 clips with two #10 sheet metal screws in each leg.



NOTE: See [Channel Strut \(Unistrut\) on page 83](#) for structural member spacing greater than 432 mm, up to 610 mm.

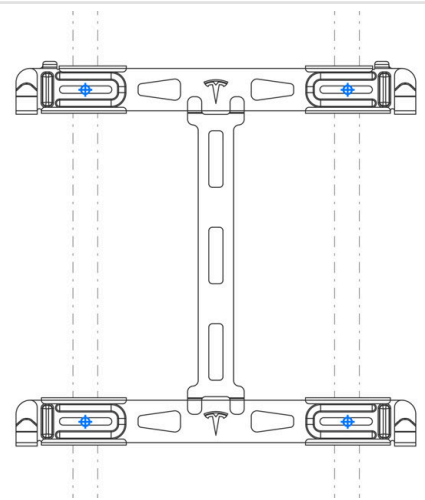



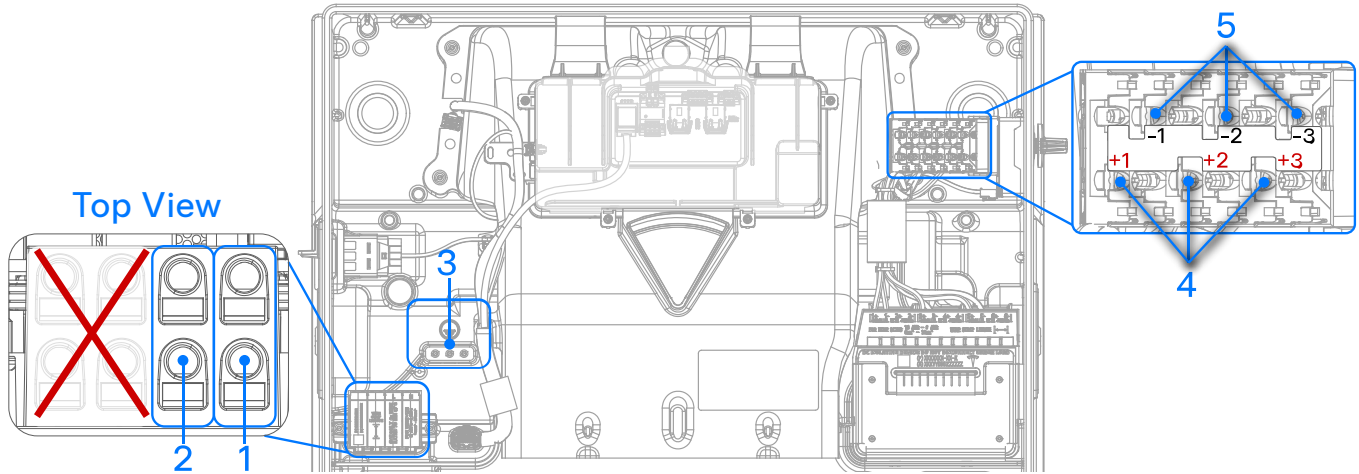

APPENDIX B: WIRING REFERENCE

Powerwall 3 AC and PV Wiring



Terminal Name	Recommended Wire Color	Wire Size
1 N (Neutral)	Black	6 - 25 mm ²
2 L1 (Line 1)	Red	
<p> NOTE: The two terminals to the left of L1 are not used.</p>		
3 Protective Earth terminals	Green	2.5 - 25 mm ²
4 Integrated DC Isolator Positive inputs (PV 1+, 2+, 3+)	Red	Use forked terminals; Tesla recommends the following or equivalent:
5 Integrated DC Isolator Negative inputs (PV 1-, 2-, 3-)	Black	<ul style="list-style-type: none"> TE Connectivity P/N 165015 (4 - 6 mm² wire size)

 **NOTE:** The two leftmost terminals in the AC connector are not used.

 **NOTE:** AC power output terminals are rated to a minimum of 90°C.

 **NOTE:** Use only copper conductors in the PV connector and GND terminals.

 **NOTE:** PV input terminals (MPPT DC inputs) are rated to a minimum of 75°C.



Tesla Asset Controller (TACO) Low Voltage and Communication Wiring

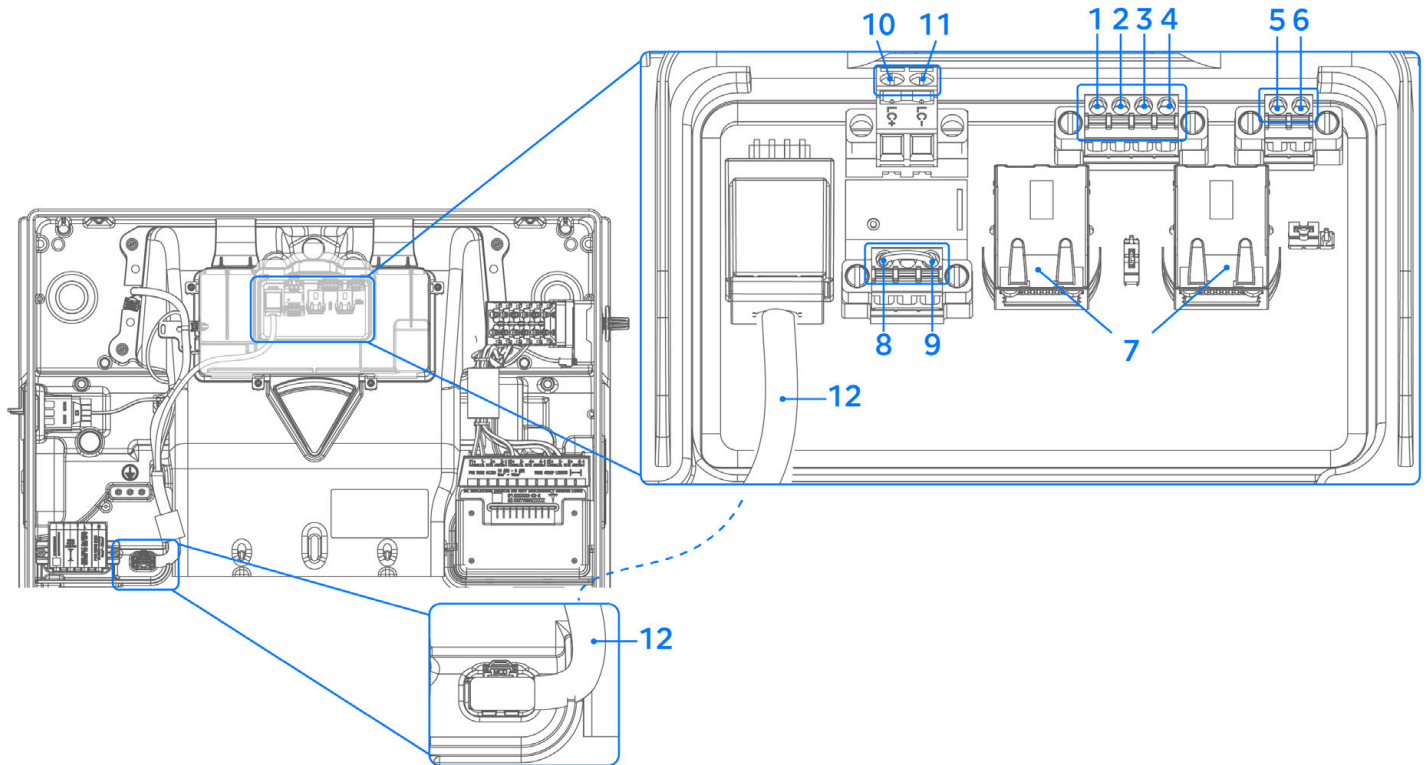

Communication Wiring to Backup Gateway 2



NOTE: Refer to local codes and standards for correct wiring practices and wire colors.

	Terminal Name	Recommended Wire Color	Wire Gauge
1	CN- (CAN LO)	Orange	0.2 - 1.5 mm ²
2	CN+ (CAN HI)	Blue	0.2 - 1.5 mm ²
3	GND (Earth)	Black	1 - 1.5 mm ²
4	12V+ (Logic+)	Red	1 - 1.5 mm ²

Remote Energy Meter Wiring (Not Yet Available)



NOTE: The remote energy metering via an external meter is not yet supported.

	Terminal Name	Recommended Wire Color	Wire Gauge
5	RS-485 +	Red	0.2 - 1.5 mm ²
6	RS-485 -	Black	0.2 - 1.5 mm ²



APPENDIX B: WIRING REFERENCE

Ethernet Jacks

	Terminal Name	Recommended Wire Color	Wire Requirements
7	RJ45 Ethernet jacks	-	CAT5 or CAT6 Ethernet wiring (see Prepare Ethernet Wiring with RJ45 Connectors on page 88)

(Optional) System Shutdown Switch Wiring

	Terminal Name	Recommended Wire Color	Wire Gauge
8	System Shutdown +	Red	0.2 - 1.5 mm ²
9	System Shutdown -	Black	0.2 - 1.5 mm ²



NOTE: The terminal between the two System Shutdown terminals is not used.

Aux Wiring (Not Yet Available)



NOTE: The load control functionality is not yet available.

	Terminal Name	Recommended Wire Color	Wire Gauge
10	Load Control +	-	0.2 - 1.5 mm ²
11	Load Control -	-	0.2 - 1.5 mm ²

TACO Low Voltage Harness

	Terminal Name	Recommended Wire Color	Wire Gauge
12	TACO low voltage harness (provides 12V power to TACO)	-	-



Prepare Ethernet Wiring with RJ45 Connectors

Recommended Tools

- RJ45 Ethernet crimping tool
- Ethernet tester

Prepare Ethernet Wiring

1. Cut the desired length of CAT5 wire.



NOTE: See [Plan Cable Length Between Components on page 29](#) for maximum wire length between components.

2. Using an RJ45 Ethernet crimping tool, crimp the RJ45 connectors to the T-568B wire color standard as shown below:

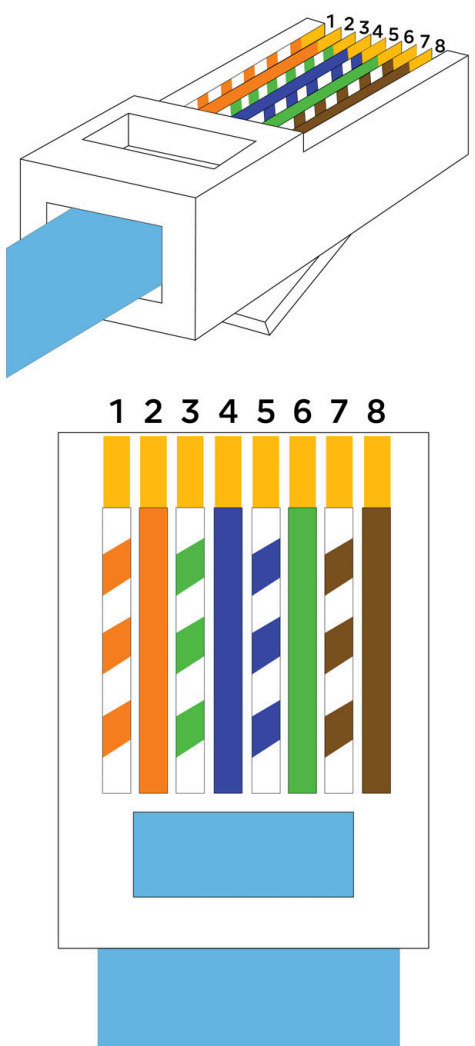
	Pin-out	Wire Color
	1	Orange striped
	2	Orange
	3	Green striped
	4	Blue
	5	Blue striped
	6	Green
	7	Brown striped
	8	Brown

3. Test the Ethernet cable using an Ethernet tester. Ensure the readings from either end of the cable match, 1-8 in ascending order.



Backup Gateway 2 Wiring

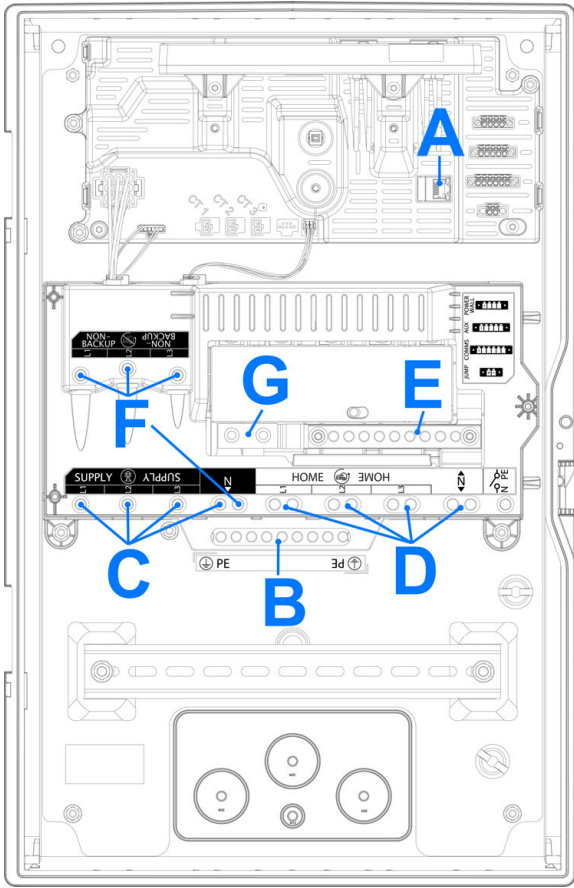

Table 3. Backup Gateway 2 Wiring: Power

	Terminal Name	Recommended Wire Color	Wire Size
A	Ethernet terminal - not used, see Ethernet Jacks on page 87		
B	Earth Bar	Green or Green/Yellow	2.5 – 25 mm ²
C	Grid Supply (L1, L2, L3, N)	Red, White, Blue, Black	2.5 – 35 mm ²
D	Backup Loads and Generation (L1, L2, L3, N)	Red, White, Blue, Black	2.5 – 35 mm ²
E	Generation Neutral Bar (N)	Black	2.5 – 25 mm ²
F	Non-Backup Loads and Generation Backup Loads and Generation (L1, L2, L3, N)	Red, White, Blue, Black	2.5 – 35 mm ²
G	Switched Neutral-Earth link	-	16 mm ²



APPENDIX B: WIRING REFERENCE

Backup Gateway 2 Communication Wiring

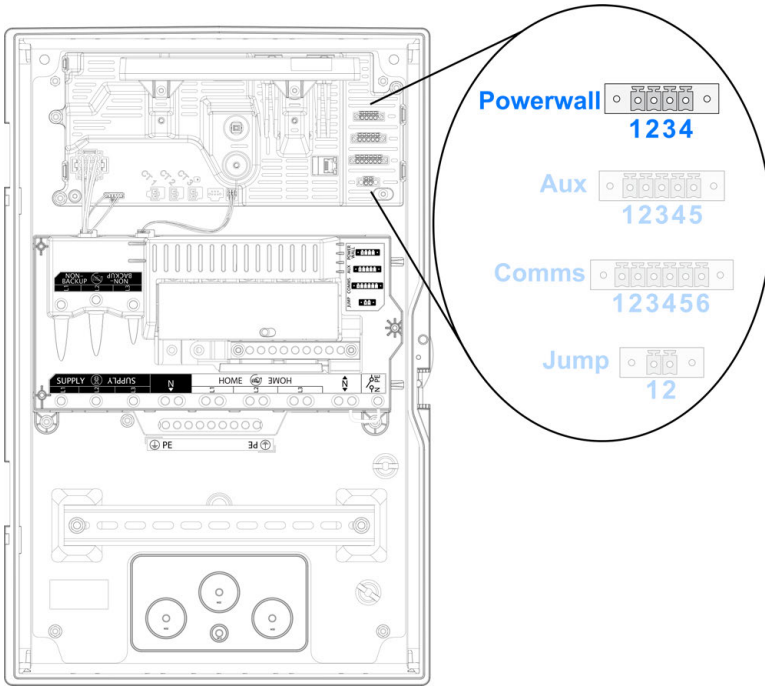

Table 4. Powerwall Communication Wiring

	Terminal Name	Recommended Wire Color	Wire Size
1	12V + (Logic +)	Red	1.0 mm ² (max 35 m) 1.5 mm ² (max 45 m)
2	GND (Earth)	Black	
3	CN + (CAN HI)	Blue	0.2 - 1.5 mm ²
4	CN - (CAN LO)	Orange	



NOTE: 4-conductor communication cable must be 300 V rated or double insulated with one twisted pair shielded copper cable.

Table 5. Aux Wiring (Not Used with Powerwall 3)

	Terminal Name	Recommended Wire Color	Wire Size
1	Site Shutdown (OUT)	-	0.2 - 1.5 mm ²
2	Site Shutdown (IN)	-	0.2 - 1.5 mm ²
3	Generator / Load Control (+)	Red	0.2 - 1.5 mm ²
4	Generator / Load Control (-)	Black	0.2 - 1.5 mm ²
5	Interlock pin	-	0.2 - 1.5 mm ²

Table 6. External Meter Communication Wiring (Not Used with Powerwall 3)

	Terminal Name	Recommended Wire Color	Wire Size
1	GND (Earth)/Shield	-	0.2 - 1.5 mm ²
2	RS485 HI #1	Red	0.2 - 1.5 mm ²
3	RS485 LO #1	Black	0.2 - 1.5 mm ²



APPENDIX B: WIRING REFERENCE

	Terminal Name	Recommended Wire Color	Wire Size
4	GND (Earth)/Shield	-	0.2 - 1.5 mm ²
5	RS485 HI #2	Red	0.2 - 1.5 mm ²
6	RS485 LO #2	Black	0.2 - 1.5 mm ²

Table 7. Jump Start (Not Used with Powerwall 3)

	Terminal Name	Recommended Wire Color	Wire Size
1	12V	Red	0.2 - 1.5 mm ²
2	GND	Black	0.2 - 1.5 mm ²



APPENDIX C: SYSTEM WIRING DIAGRAMS

Overview

The following diagrams are intended for illustration purposes only. Drawings represent sample site layouts to show example system layout and metering. These diagrams should not be considered complete plan sets.

1. Single-phase supply, single-phase solar, partial backup
2. Three-phase supply, three-phase solar, single-phase partial backup



APPENDIX C: SYSTEM WIRING DIAGRAMS

Single-Phase Service (TN Network)

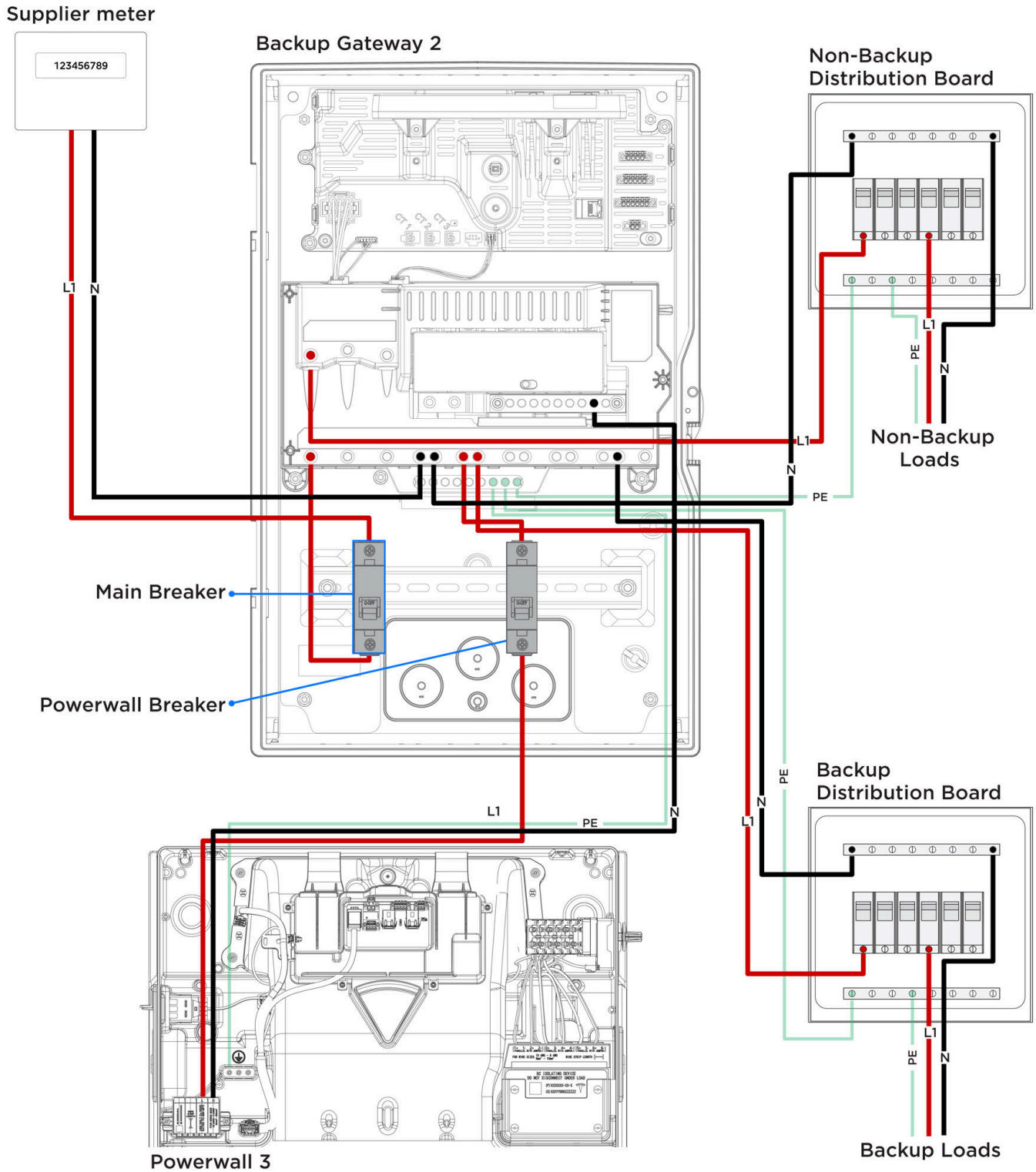



APPENDIX C: SYSTEM WIRING DIAGRAMS

Three-Phase Service (TN Network)

Supplier meter



Backup Gateway 2

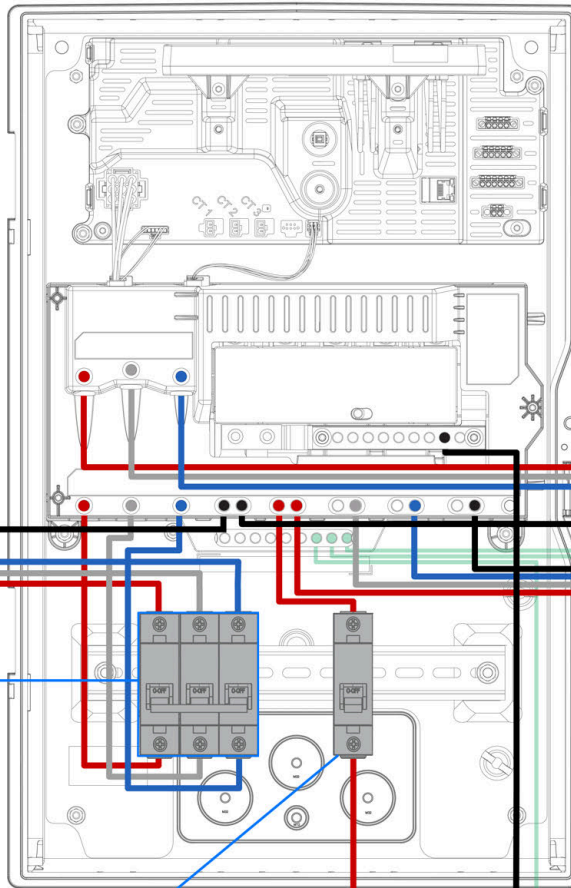

Non-Backup Distribution Board

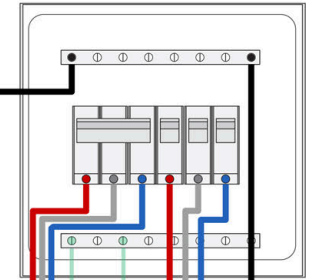

Non-Backup Loads

Main Breaker

Powerwall Breaker

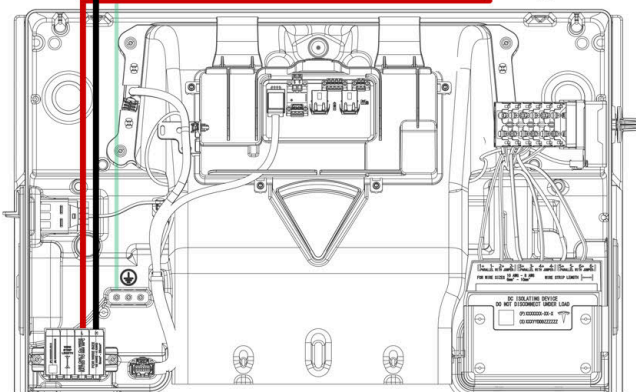

Powerwall 3

Backup Distribution Board

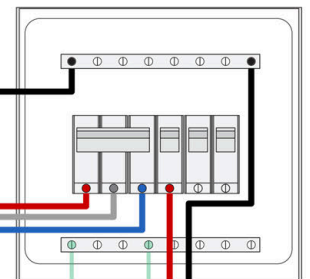

Backup Loads (1φ Only)



APPENDIX D: (OPTIONAL) INSTALL SYSTEM SHUTDOWN SWITCH

Every Powerwall 3 provides a "Shutdown" input. This shutdown input is certified and uses the worldwide standard for safety circuits where "Closed" allows operation and "Open" results in a shutdown. For normal installations of an external shutdown switch / e-stop, proceed with the instructions in [Install the System Shutdown Switch on page 95](#).

When using a DRED / DRMO shutdown input, or another source where the polarity of the control signal is flipped, wherein "Closed" requests that the system ceases operation and "Open" allows operation, instructions are included in ["Shutdown on Close" Installation, Including for DRED / DRMO Utilization in Australia on page 97](#).

The Powerwall 3 On/Off switch is also a means of shutting the system down.

 **CAUTION:** The System Shutdown Switch must be connected to Powerwall 3. Do not connect it to the Backup Gateway 2, as it will not work.

Install the System Shutdown Switch

 **WARNING:** Before terminating any conductors inside Powerwall 3, ensure that the integrated DC isolator and Powerwall 3 On/Off switch are both turned OFF to de-energize the system. Confirm lack of voltage at the AC and PV terminals before proceeding.

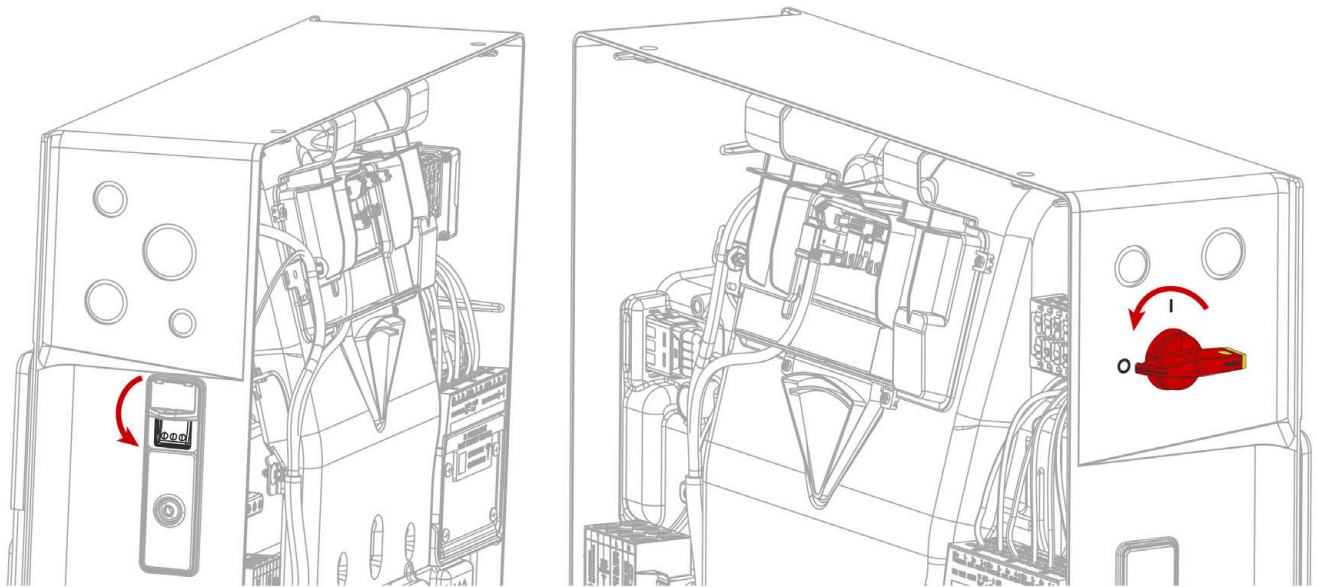

1. Remove the factory-installed jumper from the System Shutdown + / - terminals on the Powerwall 3 System Shutdown connector. See [Appendix B: Wiring Reference on page 85](#) for a detailed wiring reference.
2. Wire the 2-conductor communication wire (minimum 0.25 mm² conductors) to the System Shutdown terminals:
 - a. Strip the communication wire jacket so that it does not extend past the edge of the fan duct. This ensures the individual conductors lie flat, leaving room for the front cover to be installed.
 - b. Strip each conductor 5/16 inch (8 mm).



APPENDIX D: (OPTIONAL) INSTALL SYSTEM SHUTDOWN SWITCH

- c. Route the two conductors to the connector as shown below, using the wire management tab to prevent them from blocking the Tesla Asset Controller.

CAUTION: Tesla recommends routing the communication wiring into the left side of the enclosure; always use the wire management tabs to ensure wires do not block the Tesla Asset Controller. Do not route loose wires through the front of the enclosure.

- d. Insert a cabinet tip or electronics tip slotted screwdriver (up to 3/32-inch or 3 mm) into each screwdriver slot to open the terminal.
- e. Insert each conductor as far as possible into the terminal and remove the screwdriver from the screwdriver slot to close the terminal.

CAUTION: Excessive force may damage the connector; do not apply more force than is necessary to open the terminal and insert the conductor.

3. Connect the 2-conductor communication wire to a suitable DC switch (requirements below).

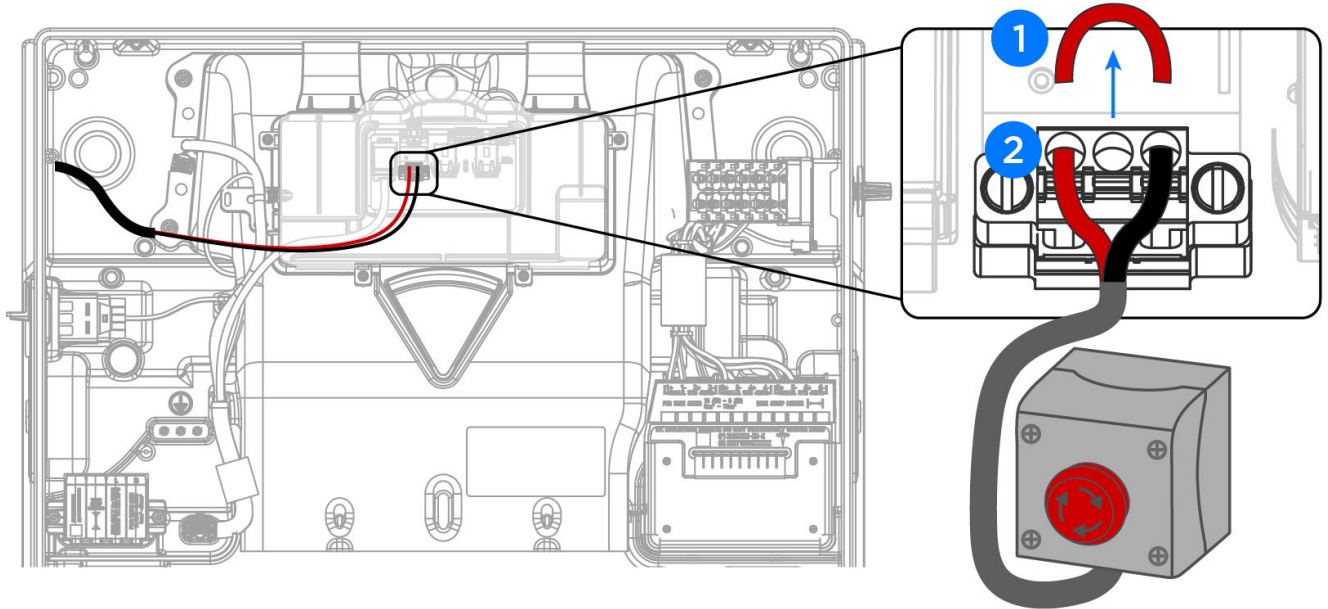

Switch Requirements

System Shutdown Switches shall meet the following requirements.

- Listed or Recognized as "Emergency Stop Button", "Emergency Stop Device", "Emergency Stop Unit", meeting one of the following standards:
 - IEC 60947-1:2020 and IEC 60947-5-1
- Rated for at least 12 V, 1 A
- Outdoor rated (IP 14 or higher)
- Terminals must accept 0.25 mm² wire or larger



APPENDIX D: (OPTIONAL) INSTALL SYSTEM SHUTDOWN SWITCH

Recommended Switch Components

The following product (composed of all parts listed below) meets all above requirements for this application:

Emergency Stop Button Option 1: Eaton	Eaton M22-PVT	Emergency Stop Button
	Eaton M22-I1-PG	Emergency Stop Enclosure
	Eaton M22-K01PV6	Emergency Stop Contactor Block (240V, 6A)
Emergency Stop Button Option 2: Schneider	Schneider XALD01H7	Emergency Stop Enclosure
	Schneider ZB5AT84	Emergency Stop Button
	Schneider ZB5AZ009	Emergency Stop Collar
	Schneider ZBE102	Emergency Stop Contact Block
	Schneider ZBZ1605	Emergency Stop Guard Yellow
	Schneider ZBZ1602	Emergency Stop Guard Black
Low voltage communication wire (Powerwall 3 communication cable preferred)		

Installation Guidelines for the System Shutdown Switch

- Up to three Powerwall 3 units can be connected to a single System Shutdown Switch
- Installed externally in a readily accessible location, preferably near utility meter
- Maximum low voltage wire run from switch does not exceed 150 ft (45 m)
- Control circuit must be installed as Type TC-ER or within an appropriate raceway

"Shutdown on Close" Installation, Including for DRED / DRMO Utilization in Australia

As mentioned in the introduction, the certified behavior of the shutdown input on Powerwall 3 is to disable operation when there is an "Open" input on the shutdown pins. When a DRED/DRMO controller is installed, or another device where the shutdown input requests disabling operation on a "Closed" input, a polarity flipping relay needs to be installed.

A polarity flipping relay is often referred to as a "Normally Closed" relay, where the absence of an input signal results in a closed output, and thus for Powerwall, an operational system.

Source the following parts:

1. DRED / DRMO controller (may be provided by the DNSP or similar)
2. A Normally Closed Relay, or a relay with a Normally Closed and Normally Open output, and a coil input at an appropriate voltage for the DRED/DRMO source being used (often 12V). One such relay commonly available at electrical distributors in Australia is <https://www.nhp.com.au/public/assets/pim/Original/10029/391124VACDC-AU-Interface-Relay-Datasheet.pdf>; however, simpler / cheaper options may be used.
3. 2-wire communication cable, for very low current (milli-amp), <24V wiring. This cable is often the same as is used for 12V power between the Powerwall and Gateway. In many locations this cable is wired alongside other AC & DC conductors, and needs to be rated accordingly (e.g. double insulated or 600V communication cable is often used).

Install the Normally Closed Relay as follows:



APPENDIX D: (OPTIONAL) INSTALL SYSTEM SHUTDOWN SWITCH

1. Install this relay in a convenient location to the DRED/DRM0 source, for example on the DIN rail within the Tesla Gateway 2.
2. Consider the DRED/DRM0 Source, and wire it to the input / coil of the relay
 - If the DRED source has an internal voltage source to drive the DRM0 signal, then this can be wired directly, with the two pins of the DRM0 signal wired to the Input / Coil side of the relay (Pins A1 & A2 in the example relay)
 - If the DRED source only provides a contact, and needs an external voltage source for controls, then 12V can be sourced from the 12V wire between the Powerwall and the Gateway (Pin 1 of the "Powerwall" port on the Gateway 2), by using a wire splice or 3-way lever-nut such as a WAGO 221-413. This 12V can then be passed into the DRM0 input pin of the DRED device, then the output DRM0 pin of the DRED device can be wired to the input of the Relay (Pin A1 in the example relay). The return pin of the relay (Pin A2 in the example relay) would then be wired to the 12V return wire between the Powerwall and the Gateway (Pin 2 of the "Powerwall" port on the Gateway 2), by using another wire splice or 3-way lever-nut such as a WAGO 221-413.
3. The two pin output of the Normally Closed Relay (Pins 11 and 12 in the example relay) are then wired directly to the two pins of the Powerwall's shutdown input (after removing the factory installed jumper, as described in step 3 in "Install the System Shutdown Switch" above)
 - Reminder: The example relay here, and others like it have a Normally Open and a Normally Closed output. It is important to use the Normally Closed output.

After installation, ensure that the system works normally when the DRED/DRM0 signal is not triggered, and the system shuts down when the DRED/DRM0 signal is triggered.

A simplified diagram of a Normally Closed Relay can be seen here:

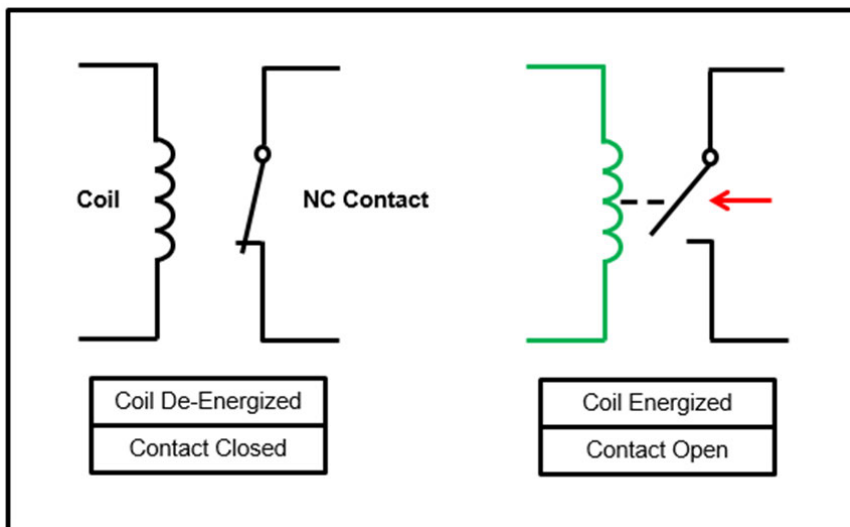

An image of the example relay can be seen here:



APPENDIX D: (OPTIONAL) INSTALL SYSTEM SHUTDOWN SWITCH





APPENDIX E: SAFETY FEATURES

Powerwall 3 Switch Locking Mechanisms

On / Off Switch Locking Mechanism

The Powerwall 3 On / Off switch has a locking mechanism. When the switch is locked it cannot be turned on.

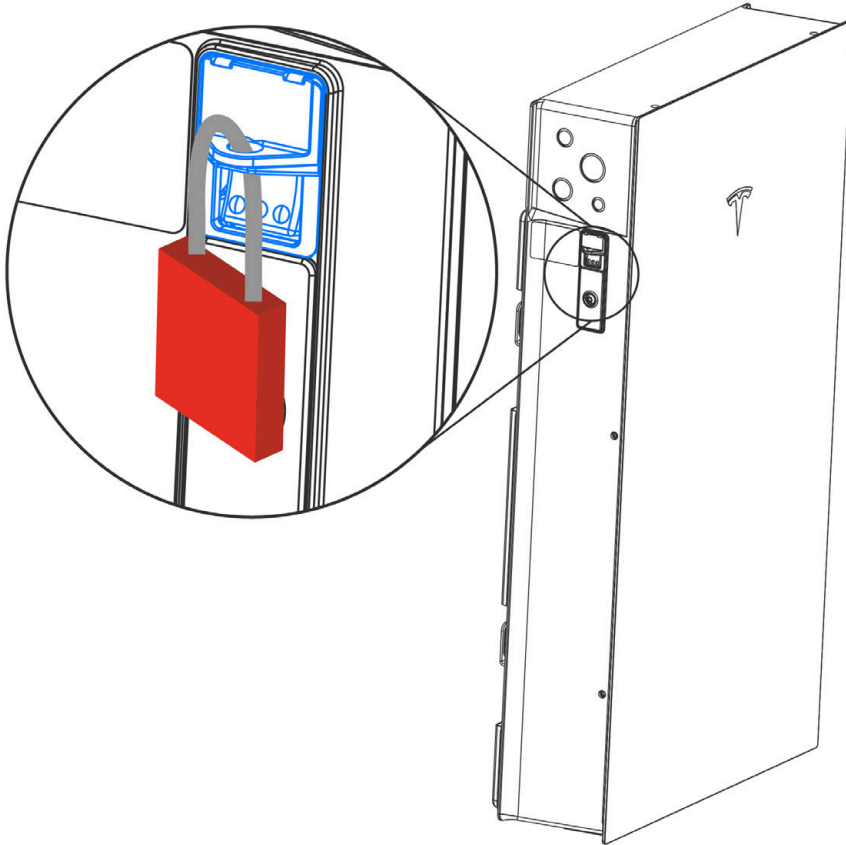



Integrated DC Isolator Locking Mechanism

The Powerwall 3 integrated DC isolator has a locking mechanism. When locked, it cannot be turned on. To use the locking mechanism:

1. Push in the yellow tab on the end of the switch to make the keyhole accessible.
2. Place a 4 mm shackle lock through the keyhole.

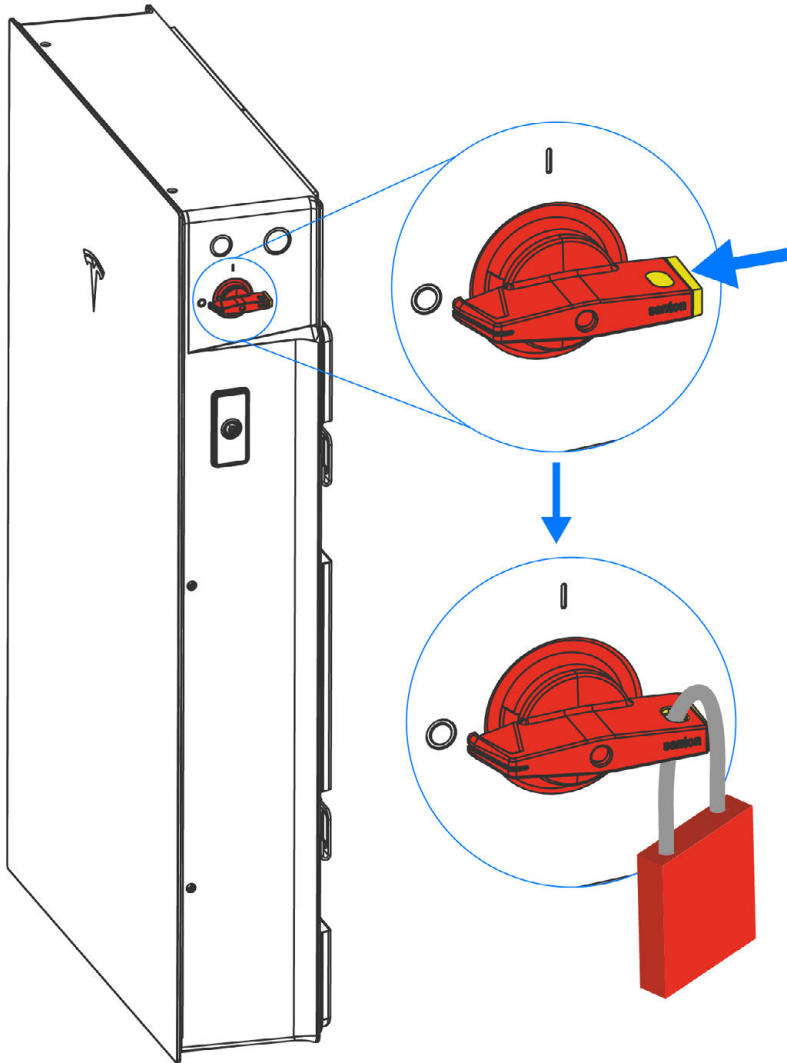

Arc Fault Detection and Protection

The Arc-Fault Circuit Interrupter (AFCI) mechanism detects series arcs within the PV array.

The detection algorithms work based on both voltage and current. When an arc fault is detected, Powerwall 3 stops converting power and disconnects from the grid. Once a fault has been detected, it can only be reset manually on-site using the mobile app via remote command. The reset cannot be automatically cleared. The fault is displayed with an LED visual indicator, which cannot be reset automatically.

To activate the AFCI self-test feature, power cycle the unit.



Protective Earth Impedance Check

The protective earth (PE) connection is checked for sufficiently low impedance at least once per day.

The scheduled time for the PE impedance test is every morning before closing the inverter side AC relays.

Upon detected loss of PE or identification of a high impedance value Powerwall 3 does not connect to the grid until the fault is cleared manually or a repeated PE impedance test demonstrates a sufficiently low impedance.



APPENDIX E: SAFETY FEATURES

System LED Behavior

Powerwall 3 LED Behavior

Tesla Logo LED

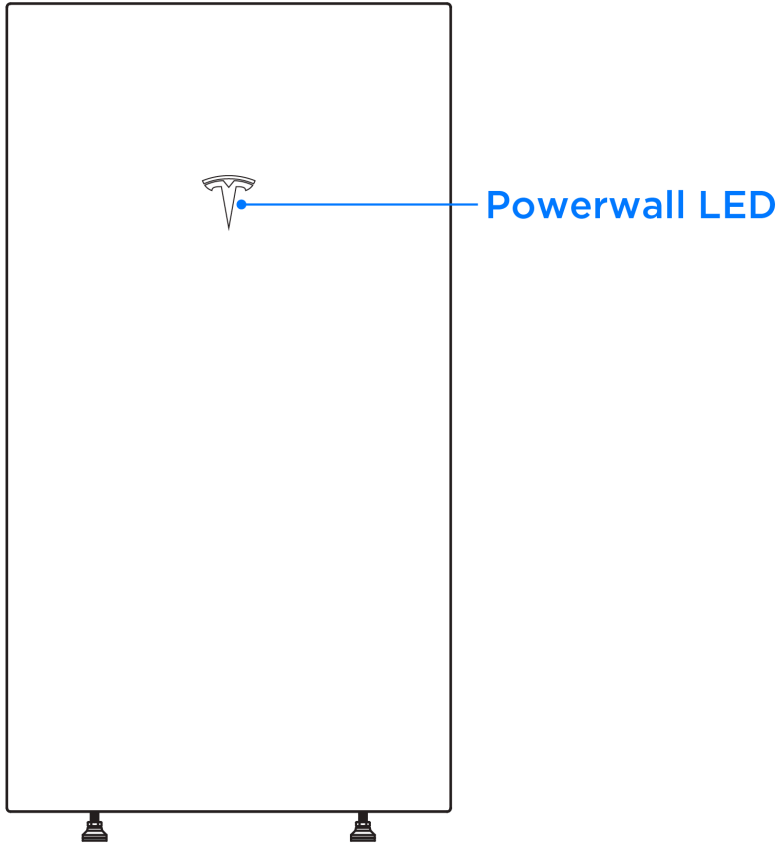

LED State	Indication
Solid white	Normal operation
Flashing white	Powerwall 3 is idle. Will enter sleep state if no actions in progress
Off	Powerwall 3 is off or in sleep state
Flashing Red	Inverter (PWS) fault, e.g. AFCI or GFCI, etc.



APPENDIX E: SAFETY FEATURES

Tesla Asset Controller (TACO) LEDs

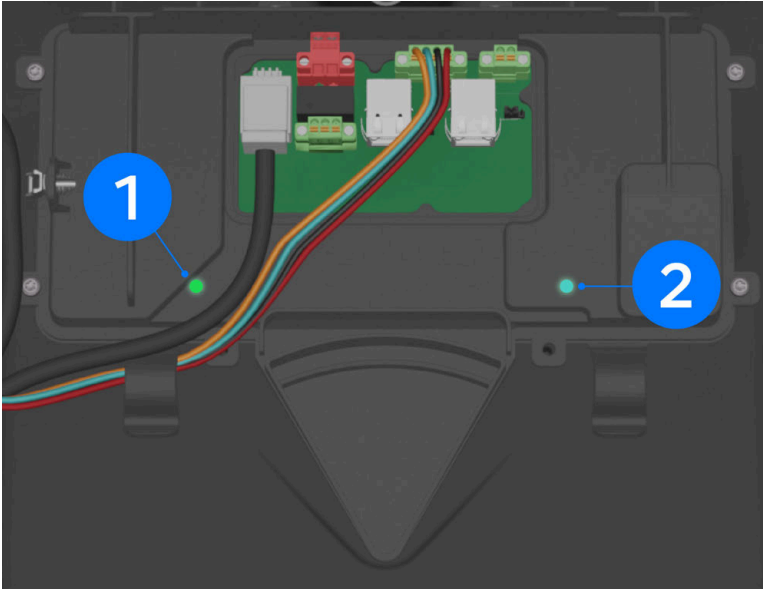



(1) Power LED	(2) Status LED	Status	Details
Solid green	Solid light blue	Ready to commission	TACO is powered and the config application is running. TeslaPW network should be broadcasting
Solid Green	Solid Green	Not ready to commission	TACO is powered but the config application is not yet running. If Powerwall 3 remains in this state permanently, contact Install Support
Solid Green	Red	Not ready to commission	TACO is powered but the unit is still booting up. If Powerwall 3 remains in this state permanently, contact Install Support
OFF	OFF	No power (12V) to TACO	<p>Note that power can be provided by either the Backup Gateway 2 12V or internal 12V.</p> <ol style="list-style-type: none"> 1. Turn the Powerwall 3 switch ON and wait at least 5 minutes 2. Confirm the TACO low voltage harness is plugged all the way in (see TACO Low Voltage Harness on page 87) 3. Confirm the 12V wiring from Backup Gateway 2 to Powerwall 3 (TACO terminals 1-4 in Communication Wiring to Backup Gateway 2 on page 86) is correct <p>If Powerwall 3 remains in this state, contact Install Support</p>

 **NOTE:** During a firmware update, LED 2 may flash red. This is expected behavior, and the flashing will stop once the firmware update is complete.

 **NOTE:** The Tesla Asset Controller LEDs are not visible when the Powerwall 3 front cover is installed.



APPENDIX F: INSTALLATIONS WITH MULTIPLE POWERWALL 3 UNITS

Maximum Number of Powerwall 3 Units	Up to (4X) Powerwall 3 units  NOTE: The maximum number of Powerwall 3 units per installation may vary by market.
Overcurrent Protection Devices	Each Powerwall 3 requires its own circuit breaker.
Site Leader	The Powerwall 3 connected to the Backup Gateway 2 over 12V/CAN wiring is designated as the Leader Powerwall 3 unit.  NOTE: The system is commissioned by connecting to the Leader Powerwall 3 unit.
Follower Unit	Any Powerwall 3 other than the Leader is connected via inter-Powerwall Ethernet wiring and is designated as a Follower unit.
Leader to Follower Communication	Ethernet (see Prepare Ethernet Wiring with RJ45 Connectors on page 88)
Internet Connection for Multiple Units	Option 1: The Leader Powerwall 3 is connected to customer router over Wi-Fi. Option 2: Either the first or last Powerwall 3 (can be Leader or Follower) in the chain is connected to customer router via Ethernet.  NOTE: Only connect the router to a Powerwall 3 at either end of the chain; do not connect it in the middle of the chain (see Connecting Powerwall 3 Units via Ethernet on page 108 for example diagrams).
Allowable Mounting Configuration	Side-by-side (front-to-back stacking is not supported for multiple Powerwall 3 units)
Maximum Wire Length Between Units	See Plan Cable Length Between Components on page 29
Splitting PV Production Between Multiple Units	Split PV production (strings) equally between the Powerwall 3 units.
System Shutdown Switch with Multiple Units	Where a single System Shutdown Switch is required, each unit must be wired to a dedicated switching pole of the switch. Ensure the installed System Shutdown Switch has enough switching poles for the number of units installed. See Appendix D: (Optional) Install System Shutdown Switch on page 95 for switch requirements and additional information.



APPENDIX F: INSTALLATIONS WITH MULTIPLE POWERWALL 3 UNITS

Figure 24. Multi-Powerwall 3 System with Backup Gateway 2

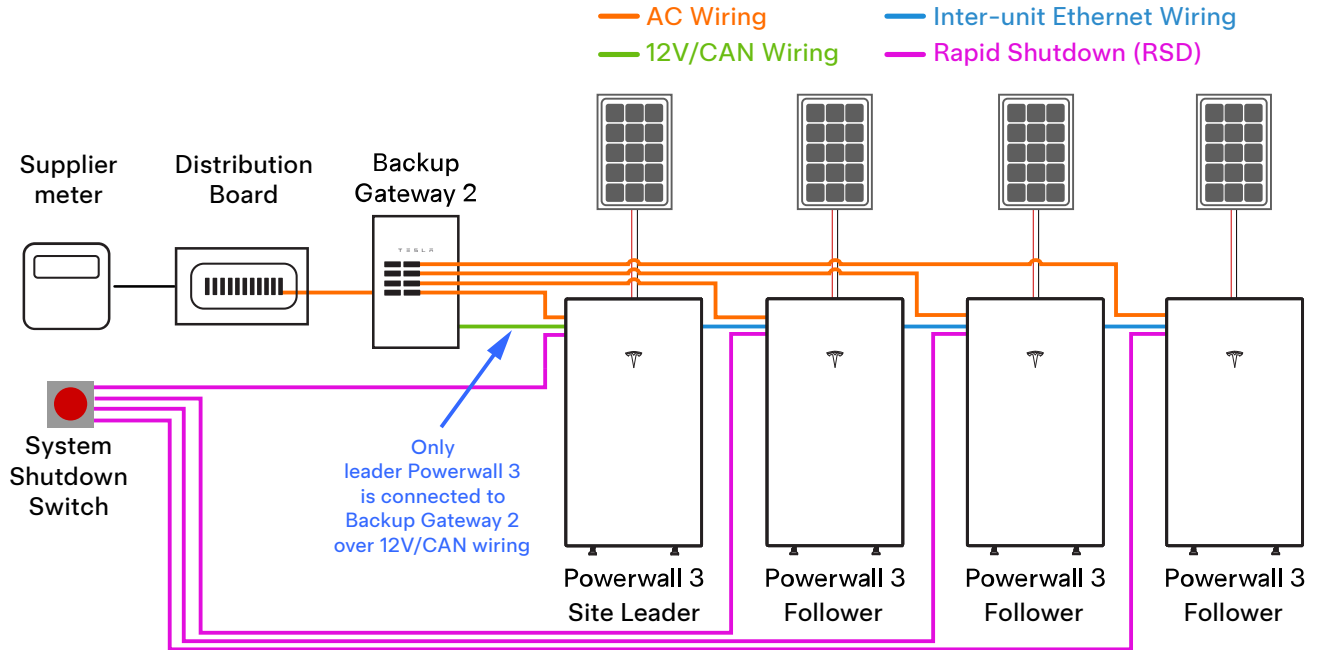



Optional System Shutdown Switch with Multiple Powerwall 3 Units

Where a System Shutdown Switch is installed, each Powerwall 3 must be wired to a dedicated switching pole of the switch. Ensure the installed System Shutdown Switch has enough switching poles for the number of units installed.

Figure 25. 4-Pole System Shutdown Switch with Four Powerwall 3 Units

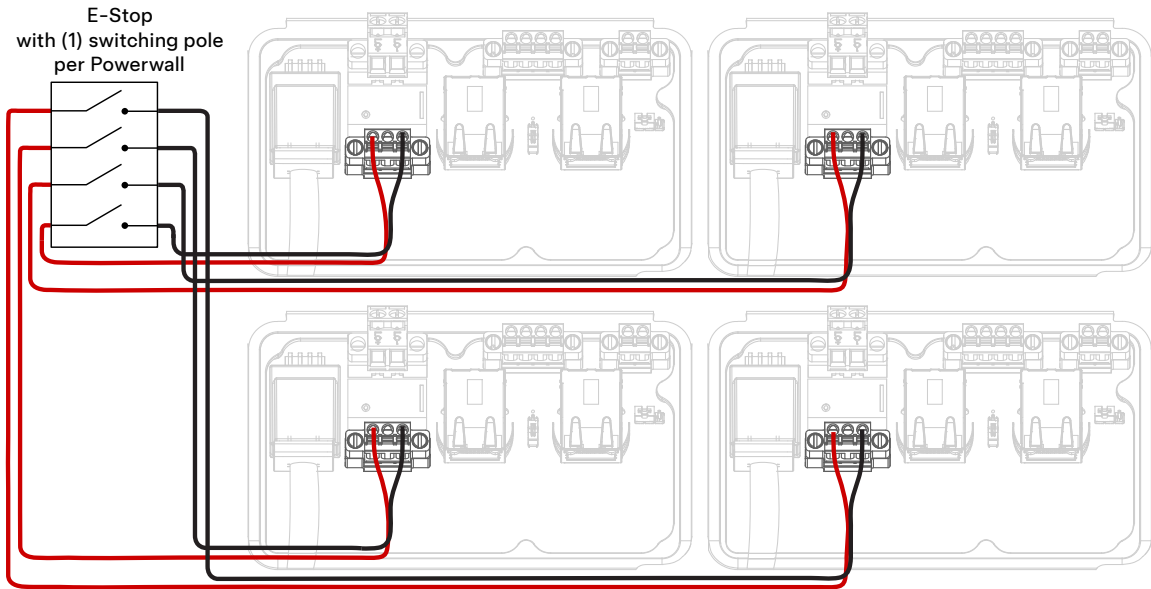

In the event multiple System Shutdown Switches are required to accommodate the number of Powerwall 3 units installed, simply install multiple switches, placing them physically near each other and following all local codes and requirements.

Figure 26. Two 3-Pole System Shutdown Switches with Four Powerwall 3 Units

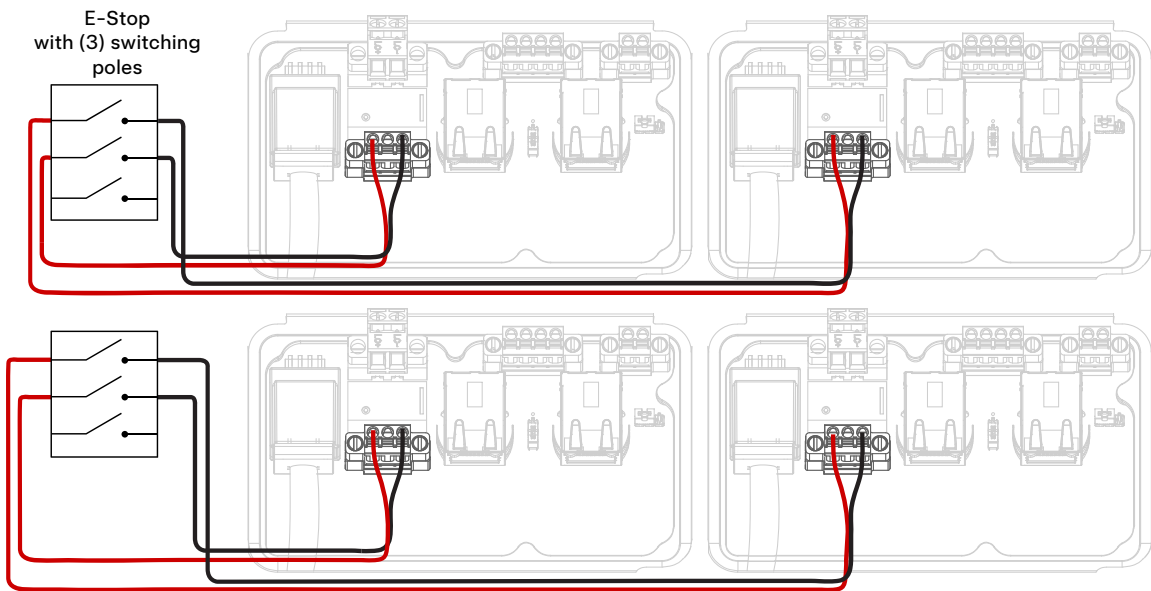



Connecting Powerwall 3 Units via Ethernet

All Powerwall 3 units must be connected via Ethernet. The units can be connected in any order, so long as each unit is connected to at least one other unit.

Figure 27. Example 1: Leader Powerwall 3 at Start of Chain, Connected to Customer Router via Wi-Fi

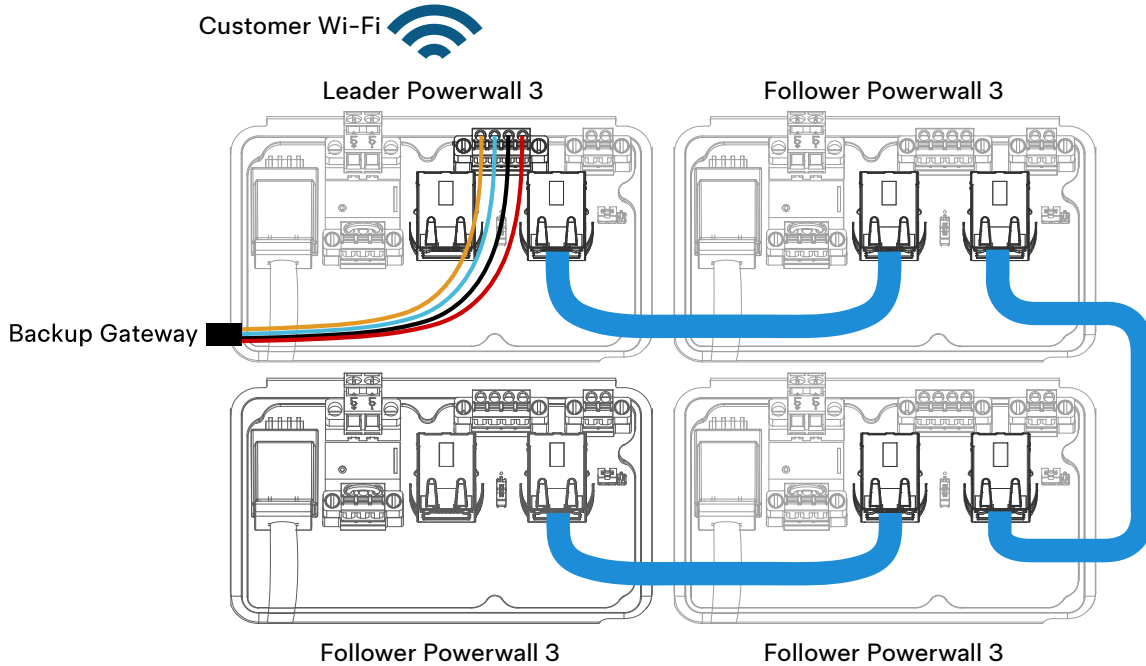
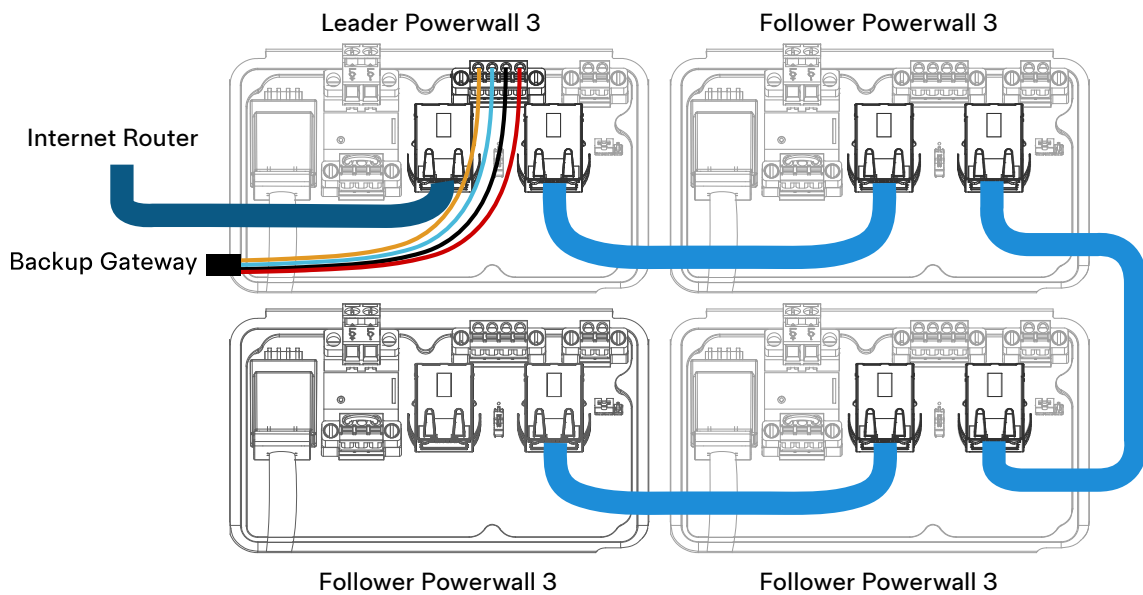

Figure 28. Example 2: Leader Powerwall 3 at Start of Chain, Connected to Customer Router via Ethernet





APPENDIX F: INSTALLATIONS WITH MULTIPLE POWERWALL 3 UNITS

Figure 29. Example 3: Leader Powerwall 3 in Middle of Chain, Connected to Customer Router via Wi-Fi

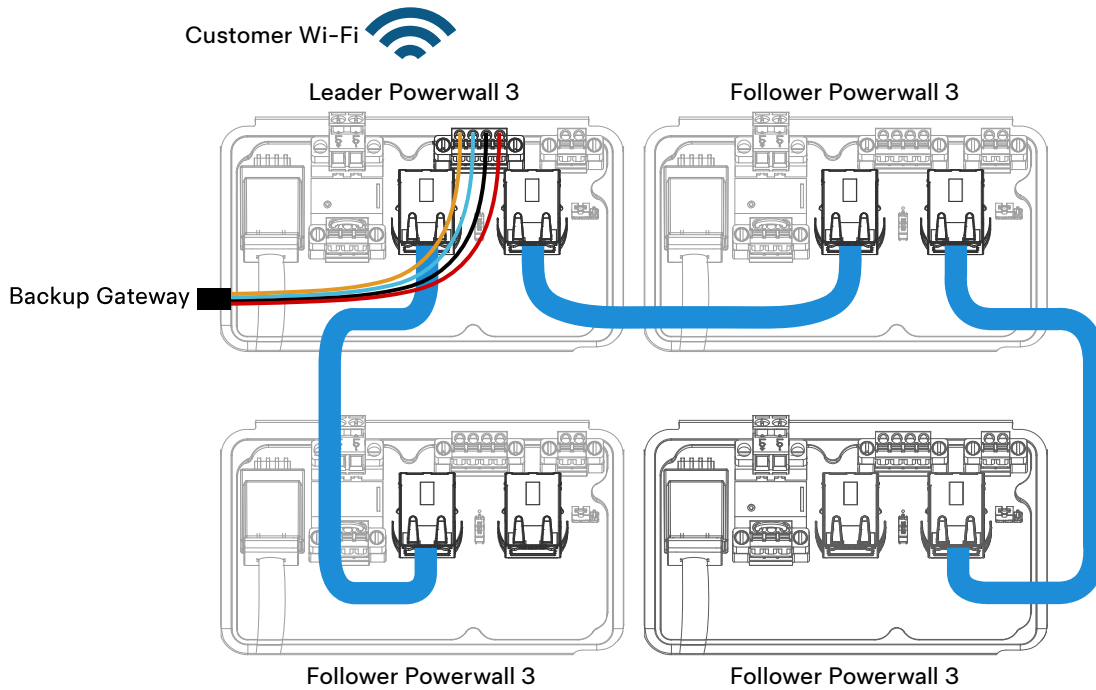

NOTE: If connecting the system to the customer router via Ethernet, connect the router to either the first or last Powerwall 3 in the chain. Do NOT connect the router in the middle of the chain.

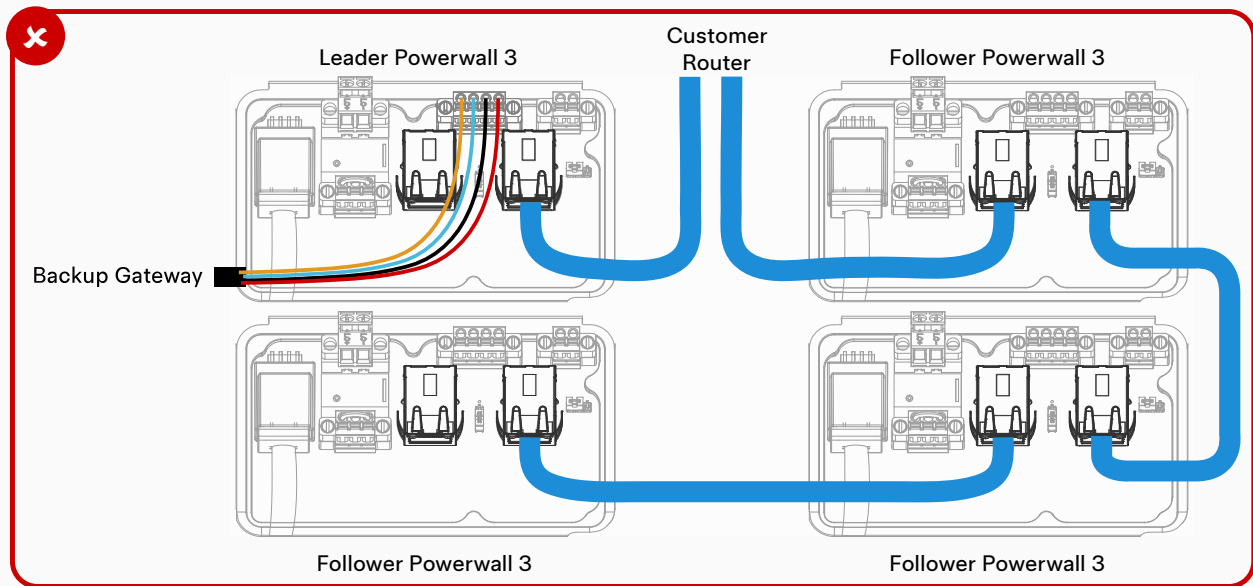

Commissioning Multi-Powerwall 3 Systems

For instructions to commission a multi-Powerwall 3 system, see the [Powerwall 3 Device Setup Guide](#).



APPENDIX G: SHUTTING DOWN POWERWALL 3

Powerwall 3 system shutdown for emergency response or maintenance requires system shutdown and disabling solar output.



CAUTION: Open all third party solar inverter breakers or handled disconnects before shutting down the Powerwall 3 system.

Safely Shut Down Powerwall 3 for Maintenance or Service

1. Turn the Powerwall 3 On/Off switch OFF.
2. Turn the Powerwall 3 integrated DC isolator switch OFF.
3. Open the Powerwall 3 AC circuit breaker.
4. Wait 30 seconds before proceeding with any work.



WARNING: Risk of electric shock from stored energy. Wait 30 seconds after disconnecting all sources of supply before proceeding.

5. Use a lock-out device on the disconnecting means listed in the table below whenever performing work on equipment that is not within sight of the switch.

Disabling Solar, System Shutdown, and Disconnecting Means for Powerwall 3

Action	Powerwall 3			AC-coupled Solar Inverter
	On/Off Switch OR Optional System Shutdown Switch	Integrated DC Isolator	AC Breaker / Isolator	AC Breaker / Isolator
Disables DC-coupled Solar	Yes	Yes	No	No
Disables AC-coupled Solar	No	No	No	Yes
Disables AC Inverter (Input and Output)	Yes	No	Yes	No



APPENDIX H: TROUBLESHOOTING

Situations in Which Powerwall 3 Stops Grid Forming

Some situations in which the Powerwall will not be allowed to grid-form are:

- The Powerwall 3 **On/Off switch is switched OFF**.
- An **open circuit** between any Powerwall and the Backup Gateway. *Example: an open Powerwall AC breaker.*
- **Excessive voltage drop** between any Powerwall and Backup Gateway. *Example: poor connections at AC wire terminals or wiring damage between Powerwall and Gateway.*
- **Loss of communications** between any internal system or meter (for instance loss of communication with Backup Gateway 2).

Earthing

When operating off-grid, the Backup Gateway 2 forms a local **TN-S supply** to the connected distribution board(s):

- *Relationship of power system to earth: T* – Direct connection of one point to Earth – this is provided by the local earth, connected into the main earthing terminal
- *Relationship of the exposed conductive parts to Earth: N* – Direct connection to the earthed point (neutral) of the power supply system - this is facilitated by the local N-PE bond created within the Gateway during off-grid operation
- *Arrangement of neutral and protective conductors: S* - Separate conductors - separate neutral and protective conductors are connected between the Gateway and downstream distribution board(s)

Proper earth connection and Neutral-to-Earth (N-PE) bonding during on-grid and off-grid operation is required for safe operation of the Powerwall system and for compliance with local code requirements. For instruction regarding the switched earth connection, refer to [Verify Neutral-Earth Bonding Scheme on page 49](#).

 **WARNING:** To ensure safe operation when operating off-grid, **a local earth must be present on the site**, such as by earth rod or ground electrode. During a grid fault it cannot be assumed that the DNO's Earth or PEN conductors are intact. Installation of earth rod must comply with local codes.



APPENDIX I: REVISION HISTORY

Revision	Date	Description
1.0	2024-08-14	Initial publication