

Compact floor standing unit with a wide selection of capacities, ideal for placement under a window sill or semi-recessed into an unused fireplace.

2.5kW  
-TO-  
6.7kW  
CAPACITY RANGE

6  
MODELS

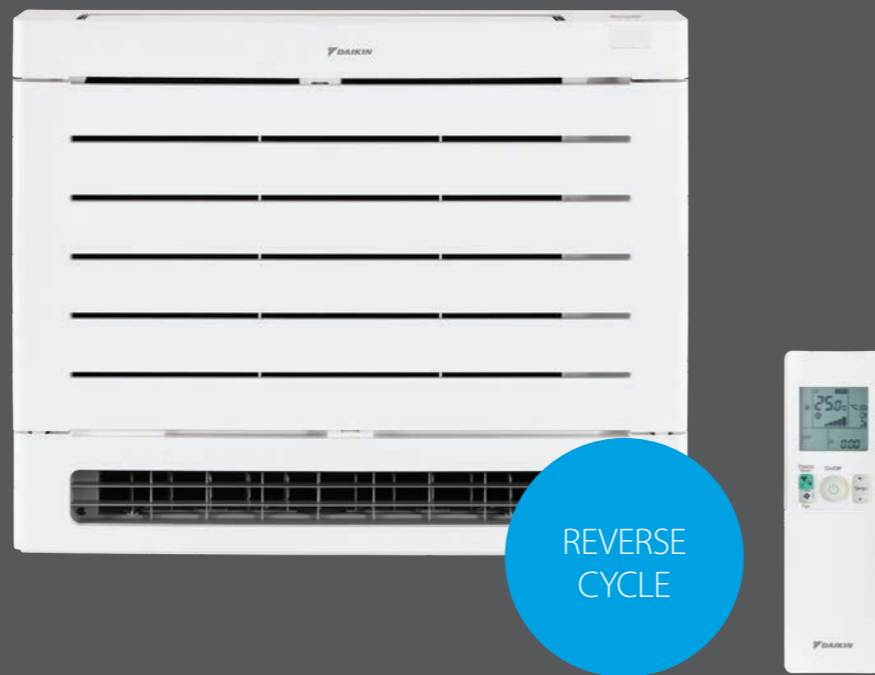

## Floor Standing

Compact & convenient

**NEW**  
R32 SERIES!



### Ultimate Heating

New Heat Plus and Heat Boost modes bring indoor heating to the next level, prioritising indoor comfort during cold nights.



### Hot start

Prior to heating, the indoor unit warms to a pre-set temperature before the fan switches on, ensuring only warm air is discharged and eliminating cold draughts.



### Advanced purification

Each model is fitted with three layers of filtration, prefilter for large particulates, enzyme blue deodorising filter for odours and Daikin's Streamer Technology for powerful oxidative decomposition of pollutants.



### Floor Warming

Optimises heat flow from the bottom louver to quickly heat the floor area around the unit with convection air flow for greater floor coverage.



### Built-in Wi-Fi

With Wi-Fi built in as standard, conveniently control everything with Daikin's Mobile Controller App or Voice Control via your Smart Home Interface.



### Mould-proof operation

Activates after cooling or dry operation to prevent the build up of mould and odour.\*

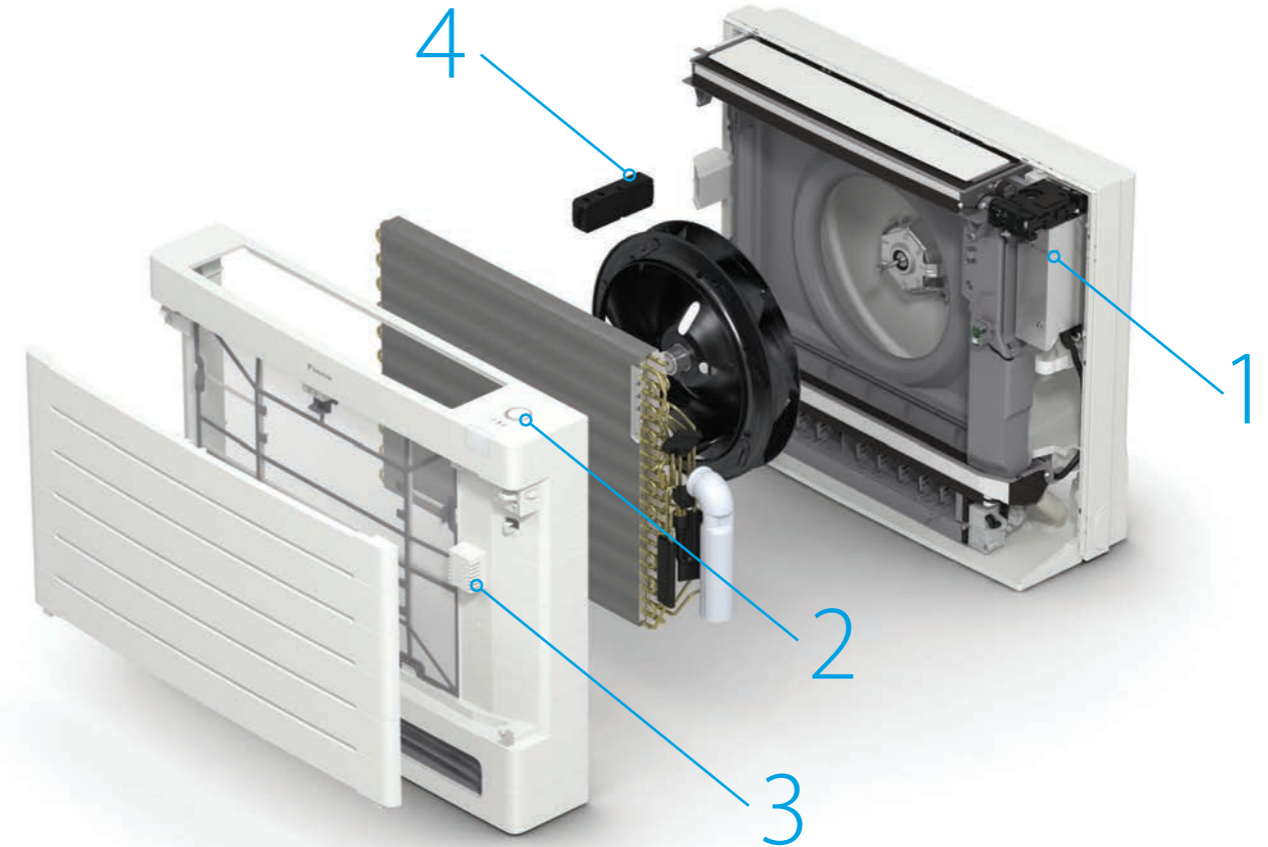

## Technology

### 1. Heat Boost Technology

Improved logic enables a boosted compressor state to help reach a comfortable indoor temperature quicker than a conventional heater.

### 2. Daikin Eye

Daikin signature eye technology enables easy, at a glance updates on unit operation mode.

### 3. Humidity sensor

Monitors humidity to accurately control supply air temperature for comfortable and effective dehumidification of your room during Program Dry Function operation.

### 4. Streamer Technology

Discharges high speed electrons generating powerful oxidative decomposition that has been proven to eliminate more than 99.6%<sup>^</sup> of pollen in 2 hours, 99.9%<sup>^^</sup> of mould in 24 hours and 99.61%<sup>^</sup> of allergens in 24 hours.



## Energy rating

STAR RATING	CLASS	25	35	45	50	60	71
ZERL (Residential)	COOL	3.5/3/3 ★	4.5/3.5/3.5 ★	3.5/3/3 ★	3/3/3 ★	4.5/3.5/3.5 ★	4.5/3.5/3.5 ★
Hot/Avg/Cold	HEAT	3/2.5/2 ★	3.5/3/2.5 ★	3/2.5/2 ★	3/2.5/2 ★	3.5/3/2.5 ★	3/2.5/2.5 ★

ZERL (Residential) refers to 'Zoned Energy Rating Label' residential star rating as outlined in the GEMS 2019 Determination

<sup>^</sup>Verified at Wakayama Medical University with the following test condition: Irradiated allergens with Streamer & checked decomposition of allergen proteins by either the ELISA method, electrophoresis or electron microscopy.

<sup>^^</sup>Verified at Japan Food Research Laboratories using antibacterial test/mould elimination test (test number: 204041635-001).

\* Mould-proof operation function can be toggled (On/Off) via the wireless controller

Note: Please see features checklist on page 33 for full list of features